



AVVISO M2C.1.1 I 1.1 - Linea d'Intervento C
"Ammodernamento (anche con ampliamento di impianti esistenti) e realizzazione di nuovi impianti innovativi di trattamento/riciclaggio per lo smaltimento di materiali assorbenti ad uso personale (PAD), i fanghi di acque reflue, i rifiuti di pelletteria e i rifiuti tessili"
REALIZZAZIONE ESSICCATORE FANGHI DI DEPURAZIONE LOCALITÀ OMIGNANO SCALO

PFTE

ELABORATO D-R-321-C85	Tabulato di calcolo Platea e tettoia soffianti	SCALA -
-------------------------------------	---	-----------------------

RUP Ing. Giovanna Ferro	Progettista Ing. Angelo Cantatore	<small>ORDINE DEGLI INGEGNERI DELLA PROVINCIA DI TRENTO</small> <small>Ingegnere civile e ambientale, industriale e dell'edilizia iscritto al N. 2532 d'Albo - Sezione A degli ingegneri</small>
	ETC ENGINEERING S.R.L. via dei Palustei 16, Meano 38121 Trento (TN) Tel: 0461 825280 - Fax: 0461 1738909 web. www.etc-eng.it - e-mail: info@etc-eng.it	

Presidente del CdA
Avv. Gennaro Maione

Direttore Generale
Ing. Maurizio Desiderio

DATA
18/10/2024
Revisione 0 - Emissione



Relazione di calcolo strutturale impostata e redatta secondo le modalità previste nel D.M. 17 Gennaio 2018 cap. 10 “Redazione dei progetti strutturali esecutivi e delle relazioni di calcolo”.

Origine e Caratteristiche dei Codici di Calcolo	
Codice di calcolo:	PRO_SAP PROfessional Structural Analysis Program
Versione:	PROFESSIONAL (build 2023-07-199)
Produttore-Distributore:	2S.I. Software e Servizi per l'Ingegneria s.r.l. Via Garibaldi, 90 44121 Ferrara FE (Italy) Tel. +39 0532 200091 www.2si.it
Codice Licenza:	Licenza dsi5862

Descrizione	
Progetto	-
	-
Ubicazione	Comune di SAPRI (SA) (Regione CAMPANIA) Località SAPRI (SA) Longitudine 15.631, Latitudine 40.075
Progettista	-

In merito al punto 10.2 delle Norme Tecniche per le Costruzioni (*Affidabilità dei codici utilizzati*), si fa riferimento al **Documento di Affidabilità** “Test di validazione del software di calcolo PRO_SAP e dei moduli aggiuntivi PRO_SAP Modulo Geotecnico, PRO_CAD nodi acciaio e PRO_MST” disponibile per il download sul sito: <https://www.2si.it/it/prodotti/affidabilita/>

INTESTAZIONE E CONTENUTI DELLA RELAZIONE

PROGETTO

Contenuti della relazione:

RELAZIONE DI CALCOLO STRUTTURALE

- *Origine e Caratteristiche dei Codici di Calcolo*
- *Affidabilità dei codici utilizzati*
- *Validazione dei codici*
- *Tipo di analisi svolta*
- *Modalità di presentazione dei risultati*
- *Informazioni generali sull'elaborazione*
- *Giudizio motivato di accettabilità dei risultati*

STAMPA DEI DATI DI INGRESSO

- *Normative prese a riferimento*
- *Criteri adottati per le misure di sicurezza*
- *Criteri seguiti nella schematizzazione della struttura, dei vincoli e delle sconnessioni*
- *Interazione tra terreno e struttura*
- *Legami costitutivi adottati per la modellazione dei materiali e dei terreni*
- *Schematizzazione delle azioni, condizioni e combinazioni di carico*
- *Metodologie numeriche utilizzate per l'analisi strutturale*
- *Metodologie numeriche utilizzate per la progettazione e la verifica degli elementi strutturali*

STAMPA DEI RISULTATI

INTESTAZIONE E CONTENUTI DELLA RELAZIONE	2
PROGETTO.....	2
RELAZIONE DI CALCOLO STRUTTURALE	5
PREMESSA	5
DESCRIZIONE GENERALE DELL'OPERA.....	5
QUADRO NORMATIVO DI RIFERIMENTO ADOTTATO	6
AZIONI DI PROGETTO SULLA COSTRUZIONE	6
MODELLO NUMERICO.....	7
Tipo di analisi strutturale	7
Informazioni sul codice di calcolo	8
Affidabilità dei codici utilizzati.....	8
MODELLAZIONE DELLE AZIONI	9
COMBINAZIONI E/O PERCORSI DI CARICO.....	9
VERIFICHE AGLI STATI LIMITE ULTIMI	11
VERIFICHE AGLI STATI LIMITE DI ESERCIZIO	11
NORMATIVA DI RIFERIMENTO.....	12
CARATTERISTICHE MATERIALI UTILIZZATI	14
LEGENDA TABELLA DATI MATERIALI	14
MODELLAZIONE DELLE SEZIONI	19
LEGENDA TABELLA DATI SEZIONI.....	19
MODELLAZIONE STRUTTURA: NODI	21
LEGENDA TABELLA DATI NODI.....	21
TABELLA DATI NODI	21
MODELLAZIONE STRUTTURA: ELEMENTI TRAVE	24
TABELLA DATI TRAVI	24
MODELLAZIONE STRUTTURA: ELEMENTI SHELL	26
LEGENDA TABELLA DATI SHELL.....	26
MODELLAZIONE DELLE AZIONI	31
LEGENDA TABELLA DATI AZIONI	31
SCHEMATIZZAZIONE DEI CASI DI CARICO.....	33
LEGENDA TABELLA CASI DI CARICO	33
DEFINIZIONE DELLE COMBINAZIONI	35
LEGENDA TABELLA COMBINAZIONI DI CARICO.....	35
AZIONE SISMICA.....	40
VALUTAZIONE DELL' AZIONE SISMICA	40
Parametri della struttura	40
RISULTATI ANALISI SISMICHE.....	43
LEGENDA TABELLA ANALISI SISMICHE	43
RISULTATI NODALI	54

LEGENDA RISULTATI NODALI	54
RISULTATI ELEMENTI TIPO TRAVE.....	79
LEGENDA RISULTATI ELEMENTI TIPO TRAVE	79
RISULTATI ELEMENTI TIPO SHELL.....	85
LEGENDA RISULTATI ELEMENTI TIPO SHELL	85
VERIFICHE PER ELEMENTI IN ACCIAIO	137
LEGENDA TABELLA VERIFICHE PER ELEMENTI IN ACCIAIO.....	137
STATI LIMITE D' ESERCIZIO ACCIAIO	141
LEGENDA TABELLA STATI LIMITE D' ESERCIZIO ACCIAIO	141
VERIFICHE ELEMENTI PARETE E/O GUSCIO IN C.A.	142
LEGENDA TABELLA VERIFICHE ELEMENTI PARETE E GUSCIO IN C.A.	142
PROGETTAZIONE DELLE FONDAZIONI	146
STATI LIMITE D' ESERCIZIO.....	153
LEGENDA TABELLA STATI LIMITE D' ESERCIZIO.....	153
STATO LIMITE D' ESERCIZIO: SLD DANNO SISMICO	157
LEGENDA TABELLA STATI LIMITE DI DANNO (VERIFICHE RES).....	157
Simbologia adottata nelle tabelle di verifica.....	157

RELAZIONE DI CALCOLO STRUTTURALE

PREMESSA

La presente relazione di calcolo strutturale, in conformità al §10.1 del DM 17/01/18, è comprensiva di una descrizione generale dell'opera e dei criteri generali di analisi e verifica. Segue inoltre le indicazioni fornite al §10.2 del DM stesso per quanto concerne analisi e verifiche svolte con l'ausilio di codici di calcolo.

Nella presente parte sono riportati i principali elementi di inquadramento del progetto esecutivo riguardante le strutture, in relazione agli strumenti urbanistici, al progetto architettonico, al progetto delle componenti tecnologiche in generale ed alle prestazioni attese dalla struttura.

DESCRIZIONE GENERALE DELL'OPERA

Descrizione generale dell'opera	
Fabbricato ad uso	
Ubicazione	Comune di SAPRI (SA) (Regione CAMPANIA)
	Località SAPRI (SA)
	Longitudine 15.631, Latitudine 40.075
Numero di piani	Fuori terra
	Interrati
	le dimensioni dell'opera in pianta sono racchiuse in un rettangolo di
Numero vani scale	
Numero vani ascensore	
Tipo di fondazione	

Principali caratteristiche della struttura	
Struttura regolare in pianta	
Struttura regolare in altezza	
Classe di duttilità	
Travi: ricalate o in spessore	
Pilastrini	
Pilastrini in falso	
Tipo di fondazione	
Condizioni per cui è necessario considerare	
la componente verticale del sisma	

Parametri della struttura			
Classe d'uso	Vita Vn [anni]	Coeff. Uso	Periodo Vr [anni]

III	50.0	1.5	75.0

Fattore di struttura/comportamento

1 – NON DISSIPATIVO

QUADRO NORMATIVO DI RIFERIMENTO ADOTTATO

Le norme ed i documenti assunti quale riferimento per la progettazione strutturale vengono indicati di seguito.

Nel capitolo “normativa di riferimento” è comunque presente l’elenco completo delle normative disponibili.

Progetto-verifica degli elementi	
Progetto cemento armato	D.M. 17-01-2018
Progetto acciaio	D.M. 17-01-2018
Progetto legno	D.M. 17-01-2018
Progetto muratura	D.M. 17-01-2018
Azione sismica	
Norma applicata per l’ azione sismica	D.M. 17-01-2018

AZIONI DI PROGETTO SULLA COSTRUZIONE

Nei capitoli “modellazione delle azioni” e “schematizzazione dei casi di carico” sono indicate le azioni sulla costruzioni.

Nel prosieguo si indicano tipo di analisi strutturale condotta (statico,dinamico, lineare o non lineare) e il metodo adottato per la risoluzione del problema strutturale nonché le metodologie seguite per la verifica o per il progetto-verifica delle sezioni. Si riportano le combinazioni di carico adottate e, nel caso di calcoli non lineari, i percorsi di carico seguiti; le configurazioni studiate per la struttura in esame *sono risultate effettivamente esaustive per la progettazione-verifica*.

La verifica della sicurezza degli elementi strutturali avviene con i metodi della scienza delle costruzioni. L’analisi strutturale è condotta con il metodo degli spostamenti per la valutazione dello stato tensodeformativo indotto da carichi statici. L’analisi strutturale è condotta con il metodo dell’analisi modale e dello spettro di risposta in termini di accelerazione per la valutazione dello stato tensodeformativo indotto da carichi dinamici (tra cui quelli di tipo sismico).

L’analisi strutturale viene effettuata con il metodo degli elementi finiti. Il metodo sopraindicato si basa sulla schematizzazione della struttura in elementi connessi solo in corrispondenza di un numero prefissato di punti denominati nodi. I nodi sono definiti dalle tre coordinate cartesiane in un sistema di riferimento globale. Le incognite del problema (nell’ambito del metodo degli spostamenti) sono le componenti di spostamento dei nodi riferite al sistema di riferimento globale (traslazioni secondo X, Y, Z, rotazioni attorno X, Y, Z). La soluzione del problema si ottiene con un sistema di equazioni algebriche lineari i cui termini noti sono costituiti dai carichi agenti sulla struttura opportunamente concentrati ai nodi:

$$K * u = F \quad \text{dove} \quad K = \text{matrice di rigidezza}$$

u = vettore spostamenti nodali

F = vettore forze nodali

Dagli spostamenti ottenuti con la risoluzione del sistema vengono quindi dedotte le sollecitazioni e/o le tensioni di ogni elemento, riferite generalmente ad una terna locale all'elemento stesso.

Il sistema di riferimento utilizzato è costituito da una terna cartesiana destrorsa XYZ. Si assume l'asse Z verticale ed orientato verso l'alto.

Gli elementi utilizzati per la modellazione dello schema statico della struttura sono i seguenti:

Elemento tipo TRUSS	(biella-D2)
Elemento tipo BEAM	(trave-D2)
Elemento tipo MEMBRANE	(membrana-D3)
Elemento tipo PLATE	(piastra-guscio-D3)
Elemento tipo BOUNDARY	(molla)
Elemento tipo STIFFNESS	(matrice di rigidità)
Elemento tipo BRICK	(elemento solido)
Elemento tipo SOLAIO	(macro elemento composto da più membrane)

MODELLO NUMERICO

In questa parte viene descritto il modello numerico utilizzato (o i modelli numerici utilizzati) per l'analisi della struttura. La presentazione delle informazioni deve essere, coerentemente con le prescrizioni del paragrafo 10.2 e relativi sottoparagrafi delle NTC-18, tale da garantirne la leggibilità, la corretta interpretazione e la riproducibilità

Tipo di analisi strutturale	
Sismica statica lineare	NO
Sismica dinamica lineare	SI
Sismica statica non lineare (prop. masse)	NO
Sismica statica non lineare (prop. modo)	NO
Sismica statica non lineare (triangolare)	NO
Non linearità geometriche (fattore P delta)	NO
Analisi lineare	SI

Di seguito si indicano l'origine e le caratteristiche dei codici di calcolo utilizzati riportando titolo, produttore e distributore, versione, estremi della licenza d'uso:

Informazioni sul codice di calcolo	
Titolo:	PRO_SAP PROfessional Structural Analysis Program
Versione:	PROFESSIONAL (build 2023-07-199)
Produttore-Distributore:	2S.I. Software e Servizi per l'Ingegneria s.r.l., Ferrara
Dati utente finale:	
Codice Utente:	
Codice Licenza:	Licenza dsi5862

Un attento esame preliminare della documentazione a corredo del software **ha consentito di valutarne l'affidabilità e soprattutto l'idoneità al caso specifico**. La documentazione, fornita dal produttore e distributore del software, contiene una esauriente descrizione delle basi teoriche e degli algoritmi impiegati, l'individuazione dei campi d'impiego, nonché casi prova interamente risolti e commentati, corredati dei file di input necessari a riprodurre l'elaborazione:

Affidabilità dei codici utilizzati
2S.I. ha verificato l'affidabilità e la robustezza del codice di calcolo attraverso un numero significativo di casi prova in cui i risultati dell'analisi numerica sono stati confrontati con soluzioni teoriche.
E' possibile reperire la documentazione contenente alcuni dei più significativi casi trattati al seguente link: https://www.2si.it/it/prodotti/affidabilita/

Modellazione della geometria e proprietà meccaniche:	
nodi	184
elementi D2 (per aste, travi, pilastri...)	8
elementi D3 (per pareti, platee, gusci...)	174
elementi solaio	1
elementi solidi	0
Dimensione del modello strutturale [cm]:	
X min =	-25.00
Xmax =	345.00
Ymin =	-25.00
Ymax =	185.00
Zmin =	0.00
Zmax =	200.00
Strutture verticali:	
Elementi di tipo asta	NO

Pilastrì	SI
Pareti	SI
Setti (a comportamento membranale)	NO
Strutture non verticali:	
Elementi di tipo asta	NO
Travi	SI
Gusci	SI
Membrane	NO
Orizzontamenti:	
Solai con la propriet� piano rigido	NO
Solai senza la propriet� piano rigido	SI
Tipo di vincoli:	
Nodi vincolati rigidamente	NO
Nodi vincolati elasticamente	NO
Nodi con isolatori sismici	NO
Fondazioni puntuali (plinti/plinti su palo)	NO
Fondazioni di tipo trave	NO
Fondazioni di tipo platea	SI
Fondazioni con elementi solidi	NO

MODELLAZIONE DELLE AZIONI

Si veda il capitolo **“Schematizzazione dei casi di carico”** per le informazioni necessarie alla comprensione ed alla ricostruzione delle azioni applicate al modello numerico, coerentemente con quanto indicato nella parte *“2.6. Azioni di progetto sulla costruzione”*.

COMBINAZIONI E/O PERCORSI DI CARICO

Si veda il capitolo **“Definizione delle combinazioni”** in cui sono indicate le combinazioni di carico adottate e, nel caso di calcoli non lineari, i percorsi di carico seguiti.

Combinazioni dei casi di carico	
APPROCCIO PROGETTUALE	Approccio 2
SLU	SI
SLV (SLU con sisma)	SI

SLC	NO
SLD	SI
SLO	NO
SLU GEO A2 (per approccio 1)	NO
SLU EQU	NO
Combinazione caratteristica (rara)	SI
Combinazione frequente	NO
Combinazione quasi permanente (SLE)	NO
SLA (accidentale quale incendio)	NO

Principali risultati

I risultati devono costituire una sintesi completa ed efficace, presentata in modo da riassumere il comportamento della struttura, per ogni tipo di analisi svolta.

Nella presente relazione di calcolo sono riportati i seguenti risultati che il progettista ritiene di interesse per la descrizione e la comprensione del/i modello/i e del comportamento della struttura:

per l'analisi modale:

- periodi dei modi di vibrare della struttura
- masse eccitate dai singoli modi
- massa eccitata totale

deformate e sollecitazioni:

- spostamenti e rotazioni dei singoli nodi della struttura
- reazioni vincolari (nel caso siano presenti nodi vincolati rigidamente)
- pressioni sul terreno (nel caso siano presenti elementi di fondazione)
- sollecitazioni sugli elementi d2 nelle combinazioni di calcolo più significative
- tensioni sugli elementi d3 nelle combinazioni di calcolo più significative
- sollecitazioni sui macroelementi da elementi d3 nelle combinazioni di calcolo più significative

La presente relazione, oltre ad illustrare in modo esaustivo i dati in ingresso ed i risultati delle analisi in forma tabellare, riporta una serie di immagini:

per i dati in ingresso:

- modello solido della struttura
- numerazione di nodi e ed elementi
- configurazioni di carico statiche
- configurazioni di carico sismiche con baricentri delle masse e eccentricità

per le combinazioni più significative (statisticamente più gravose per la struttura):

- configurazioni deformate
- diagrammi e involucri delle azioni interne
- mappe delle tensioni
- reazioni vincolari
- mappe delle pressioni sul terreno

per il progetto-verifica degli elementi:

- diagrammi di armatura
- percentuali di sfruttamento
- mappe delle verifiche più significative per i vari stati limite

Informazioni generali sull'elaborazione e giudizio motivato di accettabilità dei risultati.

Il programma prevede una serie di controlli automatici (check) che consentono l'individuazione di errori di modellazione. Al termine dell'analisi un controllo automatico identifica la presenza di spostamenti o rotazioni anormali. Si può pertanto asserire che l'elaborazione sia corretta e completa. I risultati delle elaborazioni sono stati sottoposti a controlli che ne comprovano l'attendibilità. Tale valutazione ha compreso il confronto con i risultati di semplici calcoli, eseguiti con metodi tradizionali e adottati, anche in fase di primo proporzionamento della struttura. Inoltre, sulla base di considerazioni riguardanti gli stati tensionali e deformativi determinati, si è valutata la validità delle scelte operate in sede di schematizzazione e di modellazione della struttura e delle azioni. Si allega al termine della presente relazione elenco sintetico dei controlli svolti (verifiche di equilibrio tra reazioni vincolari e carichi applicati, comparazioni tra i risultati delle analisi e quelli di valutazioni semplificate, etc.) .

VERIFICHE AGLI STATI LIMITE ULTIMI

Nel capitolo relativo alla progettazione degli elementi strutturali agli SLU vengono indicate, con riferimento alla normativa adottata, le modalità ed i criteri seguiti per valutare la sicurezza della struttura nei confronti delle possibili situazioni di crisi ed i risultati delle valutazioni svolte. In via generale, oltre alle verifiche di resistenza e di spostamento, devono essere prese in considerazione verifiche nei confronti dei fenomeni di instabilità, locale e globale, di fatica, di duttilità, di degrado.

VERIFICHE AGLI STATI LIMITE DI ESERCIZIO

Nel capitolo relativo alla progettazione degli elementi strutturali agli SLE vengono indicate, con riferimento alla normativa adottata, le modalità seguite per valutare l'affidabilità della struttura nei confronti delle possibili situazioni di perdita di funzionalità (per eccessive deformazioni, fessurazioni, vibrazioni, etc.) ed i risultati delle valutazioni svolte.

NORMATIVA DI RIFERIMENTO

1. D.Min. Infrastrutture Min. Interni e Prot. Civile 17 Gennaio 2018 e allegate "Norme tecniche per le costruzioni".
2. Circolare 21/01/19, n. 7 C.S.LL.PP "Istruzioni per l'applicazione dell'aggiornamento delle Norme Tecniche delle Costruzioni di cui al decreto ministeriale 17 gennaio 2018"
3. D.Min. Infrastrutture e trasporti 14 Settembre 2005 e allegate "Norme tecniche per le costruzioni".
4. D.M. LL.PP. 9 Gennaio 1996 "Norme tecniche per il calcolo, l'esecuzione ed il collaudo delle strutture in cemento armato, normale e precompresso e per le strutture metalliche".
5. D.M. LL.PP. 16 Gennaio 1996 "Norme tecniche relative ai <<Criteri generali per la verifica di sicurezza delle costruzioni e dei carichi e sovraccarichi>>".
6. D.M. LL.PP. 16 Gennaio 1996 "Norme tecniche per le costruzioni in zone sismiche".
7. Circolare 4/07/96, n.156AA.GG./STC. istruzioni per l'applicazione delle "Norme tecniche relative ai <<Criteri generali per la verifica di sicurezza delle costruzioni e dei carichi e sovraccarichi>>" di cui al D.M. 16/01/96.
8. Circolare 10/04/97, n.65AA.GG. istruzioni per l'applicazione delle "Norme tecniche per le costruzioni in zone sismiche" di cui al D.M. 16/01/96.
9. D.M. LL.PP. 20 Novembre 1987 "Norme tecniche per la progettazione, esecuzione e collaudo degli edifici in muratura e per il loro consolidamento".
10. Circolare 4 Gennaio 1989 n. 30787 "Istruzioni in merito alle norme tecniche per la progettazione, esecuzione e collaudo degli edifici in muratura e per il loro consolidamento".
11. D.M. LL.PP. 11 Marzo 1988 "Norme tecniche riguardanti le indagini sui terreni e sulle rocce, la stabilità dei pendii naturali e delle scarpate, i criteri generali e le prescrizioni per la progettazione, l'esecuzione e il collaudo delle opere di sostegno delle terre e delle opere di fondazione".
12. D.M. LL.PP. 3 Dicembre 1987 "Norme tecniche per la progettazione, esecuzione e collaudo delle costruzioni prefabbricate".
13. UNI 9502 - Procedimento analitico per valutare la resistenza al fuoco degli elementi costruttivi di conglomerato cementizio armato, normale e precompresso - edizione maggio 2001
14. Ordinanza del Presidente del Consiglio dei Ministri n. 3274 del 20 marzo 2003 "Primi elementi in materia di criteri generali per la classificazione sismica del territorio nazionale e di normative tecniche per le costruzioni in zona sismica" e successive modificazioni e integrazioni.
15. UNI EN 1990:2006 13/04/2006 Eurocodice 0 - Criteri generali di progettazione strutturale.
16. UNI EN 1991-1-1:2004 01/08/2004 Eurocodice 1 - Azioni sulle strutture - Parte 1-1: Azioni in generale - Pesì per unità di volume, pesì propri e sovraccarichi per gli edifici.
17. UNI EN 1991-2:2005 01/03/2005 Eurocodice 1 - Azioni sulle strutture - Parte 2: Carichi da traffico sui ponti.
18. UNI EN 1991-1-3:2004 01/10/2004 Eurocodice 1 - Azioni sulle strutture - Parte 1-3: Azioni in generale - Carichi da neve.
19. UNI EN 1991-1-4:2005 01/07/2005 Eurocodice 1 - Azioni sulle strutture - Parte 1-4: Azioni in generale - Azioni del vento.
20. UNI EN 1991-1-5:2004 01/10/2004 Eurocodice 1 - Azioni sulle strutture - Parte 1-5: Azioni in generale - Azioni termiche.
21. UNI EN 1992-1-1:2005 24/11/2005 Eurocodice 2 - Progettazione delle strutture di calcestruzzo - Parte 1-1: Regole generali e regole per gli edifici.
22. UNI EN 1992-1-2:2005 01/04/2005 Eurocodice 2 - Progettazione delle strutture di calcestruzzo - Parte 1-2: Regole generali - Progettazione strutturale contro l'incendio.

23. UNI EN 1993-1-1:2005 01/08/2005 Eurocodice 3 - Progettazione delle strutture di acciaio - Parte 1-1: Regole generali e regole per gli edifici.
24. UNI EN 1993-1-8:2005 01/08/2005 Eurocodice 3 - Progettazione delle strutture di acciaio - Parte 1-8: Progettazione dei collegamenti.
25. UNI EN 1994-1-1:2005 01/03/2005 Eurocodice 4 - Progettazione delle strutture composte acciaio-calcestruzzo - Parte 1-1: Regole generali e regole per gli edifici.
26. UNI EN 1994-2:2006 12/01/2006 Eurocodice 4 - Progettazione delle strutture composte acciaio-calcestruzzo - Parte 2: Regole generali e regole per i ponti.
27. UNI EN 1995-1-1:2005 01/02/2005 Eurocodice 5 - Progettazione delle strutture di legno - Parte 1-1: Regole generali – Regole comuni e regole per gli edifici.
28. UNI EN 1995-2:2005 01/01/2005 Eurocodice 5 - Progettazione delle strutture di legno - Parte 2: Ponti.
29. UNI EN 1996-1-1:2006 26/01/2006 Eurocodice 6 - Progettazione delle strutture di muratura - Parte 1-1: Regole generali per strutture di muratura armata e non armata.
30. UNI EN 1996-3:2006 09/03/2006 Eurocodice 6 - Progettazione delle strutture di muratura - Parte 3: Metodi di calcolo semplificato per strutture di muratura non armata.
31. UNI EN 1997-1:2005 01/02/2005 Eurocodice 7 - Progettazione geotecnica - Parte 1: Regole generali.
32. UNI EN 1998-1:2005 01/03/2005 Eurocodice 8 - Progettazione delle strutture per la resistenza sismica - Parte 1: Regole generali, azioni sismiche e regole per gli edifici.
33. UNI EN 1998-3:2005 01/08/2005 Eurocodice 8 - Progettazione delle strutture per la resistenza sismica - Parte 3: Valutazione e adeguamento degli edifici.
34. UNI EN 1998-5:2005 01/01/2005 Eurocodice 8 - Progettazione delle strutture per la resistenza sismica - Parte 5: Fondazioni, strutture di contenimento ed aspetti geotecnici.
35. CNR DT-200/2013 - Istruzioni per la Progettazione, l'Esecuzione ed il Controllo di Interventi di Consolidamento Statico mediante l'utilizzo di Compositi Fibrorinforzati
36. CNR DT-215/2018 - Istruzioni per la Progettazione, l'Esecuzione ed il Controllo di Interventi di Consolidamento Statico mediante l'utilizzo di Compositi Fibrorinforzati a Matrice Inorganica

NOTA: il presente capitolo riporta l'elenco delle normative implementate nel software. Le norme utilizzate per la struttura oggetto della presente relazione sono indicate nel precedente capitolo "RELAZIONE DI CALCOLO STRUTTURALE" "ANALISI E VERIFICHE SVOLTE CON L'AUSILIO DI CODICI DI CALCOLO".

Laddove nei capitoli successivi vengano richiamate normative antecedenti al DM 17.01.18 è dovuto alla progettazione simulata di edificio esistente.

CARATTERISTICHE MATERIALI UTILIZZATI

LEGENDA TABELLA DATI MATERIALI

Il programma consente l'uso di materiali diversi. Sono previsti i seguenti tipi di materiale:

1	materiale tipo cemento armato
2	materiale tipo acciaio
3	materiale tipo muratura
4	materiale tipo legno
5	materiale tipo generico

I materiali utilizzati nella modellazione sono individuati da una sigla identificativa ed un codice numerico (gli elementi strutturali richiamano quest'ultimo nella propria descrizione). Per ogni materiale vengono riportati in tabella i seguenti dati:

Young	modulo di elasticità normale E
Poisson	coefficiente di contrazione trasversale ν
G	modulo di elasticità tangenziale
Gamma	peso specifico
Alfa	coefficiente di dilatazione termica
Fattore di confidenza FC m	Fattore di confidenza specifico per materiale; (è riportato solo se diverso da quello globale della struttura)
Fattore di confidenza FC a	Fattore di confidenza specifico per l'armatura (è riportato solo se diverso da quello globale della struttura)
Elasto-plastico	Materiale elastico perfettamente plastico per aste non lineari
Massima compressione	Massima tensione di compressione per aste non lineari
Massima trazione	Massima tensione di trazione per aste non lineari
Fattore attrito	Coefficiente di attrito per aste non lineari
Rapporto HRDb	Rapporto di hardening a flessione
Rapporto HRDv	Rapporto di hardening a taglio

I dati soprariportati vengono utilizzati per la modellazione dello schema statico e per la determinazione dei carichi inerziali e termici. In relazione al tipo di materiale vengono riportati inoltre:

1	c.a.	Resistenza Rc	resistenza a compressione cubica
		Resistenza fctm	resistenza media a trazione semplice
		Coefficiente ksb	Coefficiente di riduzione della resistenza a compressione da utilizzare nello stress block
2	acciaio		

	Tensione f_t	Valore della tensione di rottura
	Tensione f_y	Valore della tensione di snervamento
	Resistenza f_d	Resistenza di calcolo per SL CNR-UNI 10011
	Resistenza $f_d (>40)$	Resistenza di calcolo per SL CNR-UNI 10011 per spessori $> 40\text{mm}$
	Tensione ammissibile	Tensione ammissibile CNR-UNI 10011
	Tensione ammissibile(>40)	Tensione ammissibile CNR-UNI 10011 per spessori $> 40\text{mm}$
3	muratura	
	Muratura consolidata	Muratura per la quale si prevedono interventi di rinforzo"
	Incremento resistenza	Incremento conseguito in termini di resistenza
	Incremento rigidezza	Incremento conseguito in termini di rigidezza
	Resistenza f	Valore della resistenza a compressione
	Resistenza f_{v0}	Valore della resistenza a taglio in assenza di tensioni normali
	Resistenza f_h	Valore della resistenza a compressione orizzontale
	Resistenza f_b	Valore della resistenza a compressione dei blocchi
	Resistenza f_{bh}	Valore della resistenza a compressione dei blocchi in direzione orizzontale
	Resistenza f_{v0h}	Valore della resistenza a taglio in assenza di tensioni normali per le travi
	Resistenza f_t	Valore della resistenza a trazione per fessurazione diagonale
	Resistenza f_{lim}	Valore della massima resistenza a taglio
	Resistenza f_{bt}	Valore della resistenza a trazione dei blocchi
	Coefficiente μ	Coefficiente d'attrito utilizzato per la resistenza a taglio
	Coefficiente f_i	Coefficiente d'ingranamento utilizzato per la resistenza a taglio
	Coefficiente k_{sb}	Coefficiente di riduzione della resistenza a compressione da utilizzare nello stress block
4	legno	
	E _{0,05}	Modulo di elasticità corrispondente ad un frattile del 5%
	Resistenza f_{c0}	Valore della resistenza a compressione parallela
	Resistenza f_{t0}	Valore della resistenza a trazione parallela
	Resistenza f_m	Valore della resistenza a flessione
	Resistenza f_v	Valore della resistenza a taglio
	Resist. f_{t0k}	Resistenza caratteristica (tensione amm. per REGLES) per trazione
	Resist. f_{mk}	Resistenza caratteristica (tensione amm. per REGLES) per flessione
	Resist. f_{vk}	Resistenza caratteristica (tensione amm. per REGLES) per taglio
	Modulo E _{0,05}	Modulo elastico parallelo caratteristico
	Lamellare	lamellare o massiccio

Nel tabulato si riportano sia i valori caratteristici che medi utilizzando gli uni e/o gli altri in relazione alle richieste di normativa ed alla tipologia di verifica. (Cap.7 NTC18 per materiali nuovi, Cap.8 NTC18 e relativa circolare 21/01/2019 per materiali esistenti, Linee Guida Reluis per incamiciatura CAM, CNR-DT 200 per interventi con FRP, CNR-DT 215 per interventi con FRCM)

Vengono inoltre riportate le tabelle contenenti il riassunto delle informazioni assegnate nei criteri di progetto in uso.

Id	Tipo / Note	V. caratt.	V. medio	Young	Poisson	G	Gamma	Alfa	Altri
		daN/cm2	daN/cm2	daN/cm2		daN/cm2	daN/cm3		
1	Calcestruzzo Classe C25/30			3.145e+05	0.20	1.310e+05	2.50e-03	1.00e-05	
	Resistenza Rc	300.0							
	Resistenza fctm		25.6						
	Rapporto Rfessurata (assiale)								1.00
	Rapporto Rfessurata (flessione)								1.00
	Rapporto Rfessurata (taglio)								1.00
	Coefficiente ksb								0.85
	Rapporto HRDb								1.00e-05
	Rapporto HRDv								1.00e-05
11	Acciaio Fe360 - S235-acciaio Fe360-S235			2.100e+06	0.30	8.077e+05	7.85e-03	1.20e-05	
	Tensione ft	3600.0							
	Resistenza fd	2350.0							
	Resistenza fd (>40)	2100.0							
	Tensione ammissibile	1600.0							
	Tensione ammissibile (>40)	1400.0							
	Rapporto HRDb								1.00e-05
	Rapporto HRDv								1.00e-05
157	Materiale inf. rigido no peso E = 1.000e+07- materiale E = 1.000e+07			1.000e+07	0.0	5.000e+06	0.0	1.20e-05	
	Rapporto HRDb								1.00e-05
	Rapporto HRDv								1.00e-05

Pilastracci acc.	1/7/..	2/8/..	3/9/..	4/10/..	5/11/..	6/12/..
Lunghezze libere						
Metodo di calcolo 2-2	Assegnato	Assegnato				
2-2 Beta assegnato	2.00	2.00				
2-2 Beta * L assegnato [cm]	0.0	0.0				
Metodo di calcolo 3-3	Assegnato	Assegnato				
3-3 Beta assegnato	2.00	2.00				
3-3 Beta * L assegnato [cm]	0.0	0.0				
1-1 Beta assegnato	1.00	1.00				
1-1 Beta * L assegnato [cm]	0.0	0.0				
Generalità						
Coefficiente gamma M0	1.05	1.05				
Coefficiente gamma M1	1.05	1.05				
Coefficiente gamma M2	1.25	1.25				
Effetti del 2 ordine	SI	SI				
Momenti equivalenti	SI	SI				
Usa condizioni I e II	SI	SI				

Travi acc.	1/7/..	2/8/..	3/9/..	4/10/..	5/11/..	6/12/..
Lunghezze libere						
3-3 Beta * L automatico	SI	SI				

Travi acc.	1/7/..	2/8/..	3/9/..	4/10/..	5/11/..	6/12/..
3-3 Beta assegnato	1.00	1.00				
3-3 Beta assegnato [cm]	0.0	0.0				
2-2 Beta * L automatico	SI	SI				
2-2 Beta assegnato	1.00	1.00				
2-2 Beta * L assegnato [cm]	0.0	0.0				
1-1 Beta * L automatico	SI	SI				
1-1 Beta assegnato	1.00	1.00				
1-1 Beta * L assegnato [cm]	0.0	0.0				
Generalità						
Coefficiente gamma M0	1.05	1.05				
Coefficiente gamma M1	1.05	1.05				
Coefficiente gamma M2	1.25	1.25				
Luce di taglio per GR [cm]	1.00	1.00				
Usa condizioni I e II	SI	SI				
Momenti equivalenti	SI	SI				

Gusci c.a.	1/7/..	2/8/..	3/9/..	4/10/..	5/11/..	6/12/..
Armatura						
Inclinazione Ax [gradi]	0.0	0.0				
Angolo Ax-Ay [gradi]	90.00	90.00				
Minima tesa	0.31	0.10				
Massima tesa	0.78	4.00				
Maglia unica centrale	NO	NO				
Copriferro [cm]	2.00	5.00				
Maglia x						
diametro	10	12				
passo	20	20				
diametro aggiuntivi	12	12				
Maglia y						
diametro	10	12				
passo	20	20				
diametro aggiuntivi	12	12				
Stati limite ultimi						
Tensione fy [daN/cm2]	4500.00	4500.00				
Tipo acciaio	tipo C	tipo C				
Coefficiente gamma s	1.15	1.15				
Coefficiente gamma c	1.50	1.50				
Verifiche con N costante	SI	SI				
Applica SLU da DIN	NO	NO				
Tensioni ammissibili						
Tensione amm. cls [daN/cm2]	97.50	97.50				
Tensione amm. acciaio [daN/cm2]	2600.00	2600.00				
Rapporto omogeneizzazione N	15.00	15.00				
Massimo rapporto area compressa/tesa	1.00	1.00				
Resistenza al fuoco						
3- intradosso	NO	NO				
3+ estradosso	NO	NO				
Tempo di esposizione R	15	15				

Solai e pannelli	1/7/..	2/8/..	3/9/..	4/10/..	5/11/..	6/12/..
Generalità						
Usa tensioni ammissibili	NO	NO				
Af inf: da traliccio	SI	SI				
Consenti armatura a taglio	NO	NO				
Incrementa armatura longitudinale per taglio	SI	SI				
Af inf: da q*L*L /	20.00	20.00				
Incremento fascia piena [cm]	5.00	5.00				
Armatura						
Minima tesa	0.15	0.15				
Massima tesa	3.00	3.00				
Minima compressa	0.0	0.0				
Af/h [cm]	7.000e-02	7.000e-02				
Stati limite ultimi						
Tensione fy [daN/cm2]	4500.00	4500.00				
Tipo acciaio	tipo C	tipo C				
Coefficiente gamma s	1.15	1.15				
Coefficiente gamma c	1.50	1.50				
Fattore di redistribuzione	0.0	0.0				
Tensioni ammissibili						
Tensione amm. cls [daN/cm2]	85.00	85.00				
Tensione amm. acciaio [daN/cm2]	2600.00	2600.00				
Rapporto omogeneizzazione N	15.00	15.00				
Massimo rapporto area compressa/tesa	1.00	1.00				
Verifica freccia						
Infinita	250.00	250.00				
Istantanea	500.00	500.00				
Fattore viscosità	3.00	3.00				
Usa J non fessurato	NO	NO				
Elementi non strutturali						
Tamponatura antiespulsione	NO	NO				
Tamponatura con armatura	NO	NO				
Fattore di struttura/comportamento	2.00	2.00				
Coefficiente gamma m	0.0	0.0				
Periodo Ta	0.0	0.0				
Altezza pannello	0.0	0.0				

MODELLAZIONE DELLE SEZIONI

LEGENDA TABELLA DATI SEZIONI

Il programma consente l'uso di sezioni diverse. Sono previsti i seguenti tipi di sezione:

1. sezione di tipo generico
2. profilati semplici
3. profilati accoppiati e speciali

Le sezioni utilizzate nella modellazione sono individuate da una sigla identificativa ed un codice numerico (gli elementi strutturali richiamano quest'ultimo nella propria descrizione). Per ogni sezione vengono riportati in tabella i seguenti dati:

Area	area della sezione
A V2	area della sezione/fattore di taglio (per il taglio in direzione 2)
A V3	area della sezione/fattore di taglio (per il taglio in direzione 3)
Jt	fattore torsionale di rigidezza
J2-2	momento d'inerzia della sezione riferito all'asse 2
J3-3	momento d'inerzia della sezione riferito all'asse 3
W2-2	modulo di resistenza della sezione riferito all'asse 2
W3-3	modulo di resistenza della sezione riferito all'asse 3
Wp2-2	modulo di resistenza plastico della sezione riferito all'asse 2
Wp3-3	modulo di resistenza plastico della sezione riferito all'asse 3

I dati sopra riportati vengono utilizzati per la determinazione dei carichi inerziali e per la definizione delle rigidezze degli elementi strutturali; qualora il valore di Area V2 (e/o Area V3) sia nullo la deformabilità per taglio V2 (e/o V3) è trascurata. La valutazione delle caratteristiche inerziali delle sezioni è condotta nel riferimento 2-3 dell'elemento.

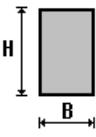
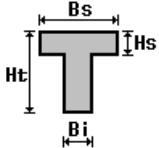
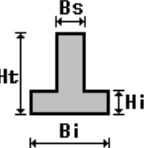
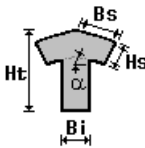
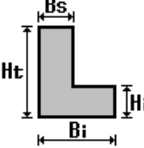
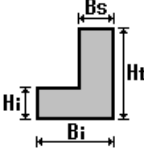
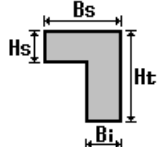
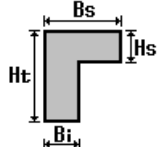
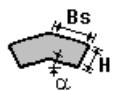
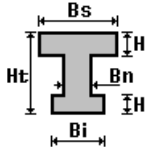
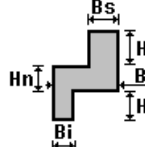
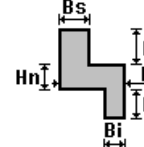
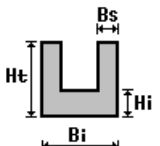
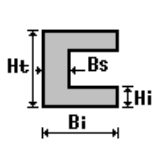
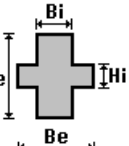
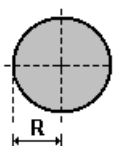
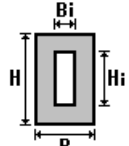
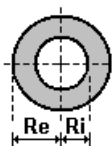
					
rettangolare	a T	a T rovescia	a T di colmo	a L	a L specchiata
					
a L specchiata rovescia	a L rovescia	a L di colmo	a doppio T	a quattro specchiata	a quattro
					
a U	a C	a croce	circolare	rettangolare cava	circolare cava

Per quanto concerne i profilati semplici ed accoppiati l'asse 2 del riferimento coincide con l'asse x riportato nei più diffusi profilati.

Per quanto concerne le sezioni di tipo generico (tipo 1.):
i valori dimensionali con prefisso B sono riferiti all'asse 2
i valori dimensionali con prefisso H sono riferiti all'asse 3

Id	Tipo	Area	A V2	A V3	Jt	J 2-2	J 3-3	W 2-2	W 3-3	Wp 2-2	Wp 3-3
		cm2	cm2	cm2	cm4	cm4	cm4	cm3	cm3	cm3	cm3
1	HEA 100	21.20	0.0	0.0	5.20	134.00	349.00	26.80	72.80	41.10	83.00
2	T.QU 120x3	14.04	0.0	0.0	480.48	320.53	320.53	53.42	53.42	61.61	61.61

MODELLAZIONE STRUTTURA: NODI

LEGENDA TABELLA DATI NODI

Il programma utilizza per la modellazione nodi strutturali.

Ogni nodo è individuato dalle coordinate cartesiane nel sistema di riferimento globale (X Y Z).

Ad ogni nodo è eventualmente associato un codice di vincolamento rigido, un codice di fondazione speciale, ed un set di sei molle (tre per le traslazioni, tre per le rotazioni). Le tabelle sottoriportate riflettono le succitate possibilità. In particolare per ogni nodo viene indicato in tabella:

Nodo	numero del nodo.
X	valore della coordinata X
Y	valore della coordinata Y
Z	valore della coordinata Z

Per i nodi ai quali sia associato un codice di vincolamento rigido, un codice di fondazione speciale o un set di molle viene indicato in tabella:

Nodo	numero del nodo.
X	valore della coordinata X
Y	valore della coordinata Y
Z	valore della coordinata Z
Note	eventuale codice di vincolo (es. v=110010 sei valori relativi ai sei gradi di libertà previsti per il nodo TxTyTzRxRyRz, il valore 1 indica che lo spostamento o rotazione relativo è impedito, il valore 0 indica che lo spostamento o rotazione relativo è libero).
Note	(FS = 1, 2,...) eventuale codice del tipo di fondazione speciale (1, 2,... fanno riferimento alle tipologie: plinto, palo, plinto su pali,...) che è collegato al nodo. (ISO = "id SIGLA") indice e sigla identificativa dell' eventuale isolatore sismico assegnato al nodo
Rig. TX	valore della rigidezza dei vincoli elastici eventualmente applicati al nodo, nello specifico TX (idem per TY, TZ, RX, RY, RZ).

Per strutture sismicamente isolate viene inoltre inserita la tabella delle caratteristiche per gli isolatori utilizzati; le caratteristiche sono indicate in conformità al cap. 7.10 del D.M. 17/01/18

TABELLA DATI NODI

Nodo	X	Y	Z	Nodo	X	Y	Z	Nodo	X	Y	Z
	cm	cm	cm		cm	cm	cm		cm	cm	cm
1	0.0	0.0	0.0	2	320.0	0.0	0.0	3	320.0	160.0	0.0
4	0.0	160.0	0.0	5	20.0	0.0	0.0	6	20.0	160.0	0.0
7	300.0	0.0	0.0	8	300.0	160.0	0.0	9	0.0	20.0	0.0
10	320.0	20.0	0.0	11	0.0	140.0	0.0	12	320.0	140.0	0.0
13	20.0	140.0	0.0	14	20.0	20.0	0.0	15	300.0	140.0	0.0

16	300.0	20.0	0.0	17	140.0	140.0	0.0	18	140.0	20.0	0.0
19	220.0	140.0	0.0	20	220.0	20.0	0.0	21	220.0	160.0	0.0
22	220.0	0.0	0.0	23	140.0	160.0	0.0	24	140.0	0.0	0.0
25	260.0	0.0	0.0	26	260.0	160.0	0.0	27	80.0	0.0	0.0
28	80.0	160.0	0.0	29	80.0	140.0	0.0	30	80.0	20.0	0.0
31	260.0	140.0	0.0	32	260.0	20.0	0.0	33	0.0	80.0	0.0
34	320.0	80.0	0.0	35	300.0	80.0	0.0	36	20.0	80.0	0.0
37	260.0	80.0	0.0	38	220.0	80.0	0.0	39	140.0	80.0	0.0
40	80.0	80.0	0.0	41	10.0	0.0	0.0	42	10.0	160.0	0.0
43	310.0	0.0	0.0	44	310.0	160.0	0.0	45	0.0	10.0	0.0
46	320.0	10.0	0.0	47	0.0	150.0	0.0	48	320.0	150.0	0.0
49	300.0	150.0	0.0	50	20.0	150.0	0.0	51	260.0	150.0	0.0
52	220.0	150.0	0.0	53	140.0	150.0	0.0	54	80.0	150.0	0.0
55	310.0	150.0	0.0	56	310.0	80.0	0.0	57	310.0	140.0	0.0
58	310.0	20.0	0.0	59	310.0	10.0	0.0	60	20.0	10.0	0.0
61	300.0	10.0	0.0	62	260.0	10.0	0.0	63	220.0	10.0	0.0
64	140.0	10.0	0.0	65	80.0	10.0	0.0	66	10.0	150.0	0.0
67	10.0	80.0	0.0	68	10.0	140.0	0.0	69	10.0	10.0	0.0
70	10.0	20.0	0.0	71	220.0	40.0	80.0	72	300.0	120.0	80.0
73	300.0	40.0	80.0	74	80.0	80.0	120.0	75	220.0	120.0	80.0
76	140.0	140.0	120.0	77	140.0	20.0	120.0	78	20.0	20.0	120.0
79	20.0	140.0	120.0	80	310.0	150.0	200.0	81	0.0	120.0	0.0
82	320.0	120.0	0.0	83	0.0	40.0	0.0	84	320.0	40.0	0.0
85	310.0	40.0	0.0	86	20.0	40.0	0.0	87	10.0	40.0	0.0
88	300.0	40.0	0.0	89	260.0	40.0	0.0	90	220.0	40.0	0.0
91	140.0	40.0	0.0	92	80.0	40.0	0.0	93	310.0	120.0	0.0
94	20.0	120.0	0.0	95	10.0	120.0	0.0	96	300.0	120.0	0.0
97	260.0	120.0	0.0	98	220.0	120.0	0.0	99	140.0	120.0	0.0
100	80.0	120.0	0.0	101	10.0	150.0	200.0	102	10.0	10.0	200.0
103	310.0	10.0	200.0	104	140.0	20.0	60.0	105	220.0	40.0	40.0
106	140.0	140.0	60.0	107	20.0	140.0	60.0	108	20.0	20.0	60.0
109	220.0	120.0	40.0	110	300.0	120.0	40.0	111	300.0	40.0	40.0
112	80.0	140.0	60.0	113	80.0	20.0	60.0	114	20.0	80.0	60.0
115	140.0	80.0	60.0	116	80.0	80.0	60.0	117	20.0	40.0	60.0
118	140.0	40.0	60.0	119	80.0	40.0	60.0	120	20.0	120.0	60.0
121	140.0	120.0	60.0	122	80.0	120.0	60.0	123	300.0	80.0	40.0
124	260.0	80.0	40.0	125	220.0	80.0	40.0	126	260.0	40.0	40.0
127	260.0	120.0	40.0	128	260.0	40.0	80.0	129	260.0	120.0	80.0
130	300.0	80.0	80.0	131	220.0	80.0	80.0	132	260.0	80.0	80.0
133	140.0	40.0	120.0	134	140.0	80.0	120.0	135	140.0	120.0	120.0
136	80.0	20.0	120.0	137	80.0	140.0	120.0	138	20.0	80.0	120.0
139	20.0	120.0	120.0	140	20.0	40.0	120.0	141	80.0	120.0	120.0
142	80.0	40.0	120.0	143	320.0	185.0	0.0	144	0.0	185.0	0.0
145	20.0	185.0	0.0	146	300.0	185.0	0.0	147	220.0	185.0	0.0
148	140.0	185.0	0.0	149	260.0	185.0	0.0	150	80.0	185.0	0.0
151	10.0	185.0	0.0	152	310.0	185.0	0.0	153	0.0	-25.0	0.0
154	320.0	-25.0	0.0	155	20.0	-25.0	0.0	156	300.0	-25.0	0.0
157	220.0	-25.0	0.0	158	140.0	-25.0	0.0	159	260.0	-25.0	0.0
160	80.0	-25.0	0.0	161	10.0	-25.0	0.0	162	310.0	-25.0	0.0
163	-25.0	80.0	0.0	164	345.0	120.0	0.0	165	345.0	40.0	0.0
166	-25.0	10.0	0.0	167	-25.0	150.0	0.0	168	345.0	185.0	0.0
169	-25.0	120.0	0.0	170	345.0	-25.0	0.0	171	-25.0	40.0	0.0
172	345.0	0.0	0.0	173	345.0	160.0	0.0	174	345.0	20.0	0.0
175	345.0	140.0	0.0	176	345.0	80.0	0.0	177	-25.0	185.0	0.0
178	-25.0	-25.0	0.0	179	345.0	10.0	0.0	180	345.0	150.0	0.0
181	-25.0	0.0	0.0	182	-25.0	160.0	0.0	183	-25.0	20.0	0.0

184

-25.0

140.0

0.0

MODELLAZIONE STRUTTURALE: ELEMENTI TRAVE

TABELLA DATI TRAVI

Il programma utilizza per la modellazione elementi a due nodi denominati in generale travi.

Ogni elemento trave è individuato dal nodo iniziale e dal nodo finale.

Ogni elemento è caratterizzato da un insieme di proprietà riportate in tabella che ne completano la modellazione.

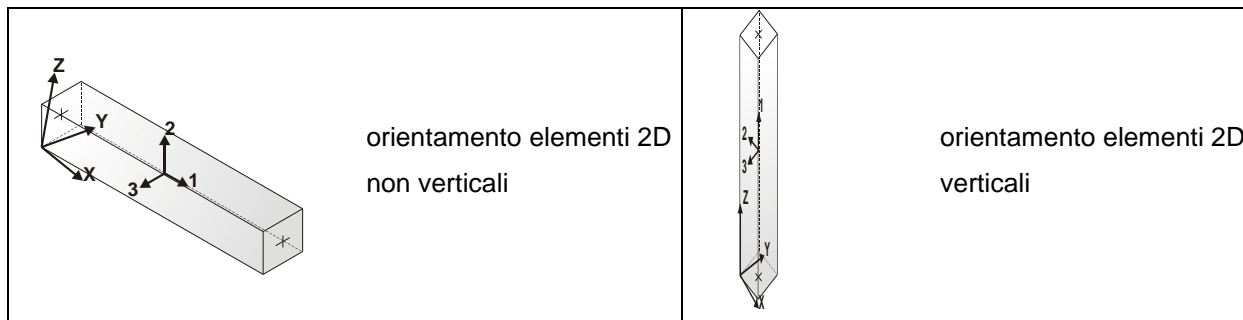

In particolare per ogni elemento viene indicato in tabella:

Elem.	numero dell'elemento
Note	codice di comportamento: trave, trave di fondazione, pilastro, asta, asta tesa, asta compressa,
Nodo I (J)	numero del nodo iniziale (finale)
Mat.	codice del materiale assegnato all'elemento
Sez.	codice della sezione assegnata all'elemento
Rotaz.	valore della rotazione dell'elemento, attorno al proprio asse, nel caso in cui l'orientamento di default non sia adottabile; l'orientamento di default prevede per gli elementi non verticali l'asse 2 contenuto nel piano verticale e l'asse 3 orizzontale, per gli elementi verticali l'asse 2 diretto secondo X negativo e l'asse 3 diretto secondo Y negativo
Svincolo I (J)	codici di svincolo per le azioni interne; i primi sei codici si riferiscono al nodo iniziale, i restanti sei al nodo finale (il valore 1 indica che la relativa azione interna non è attiva)
Wink V	costante di sottofondo (coefficiente di Winkler) per la modellazione della trave su suolo elastico
Wink O	costante di sottofondo (coefficiente di Winkler) per la modellazione del suolo elastico orizzontale

Elem.	Note	Nodo I	Nodo J	Mat.	Sez.	Crit.	Rotaz. gradi	Svincolo I	Svincolo J	Wink V daN/cm3	Wink O daN/cm3
1	Pilas.	55	80	11	2	1					
2	Pilas.	66	101	11	2	1					
3	Pilas.	69	102	11	2	1					
4	Pilas.	59	103	11	2	1					
5	Trave	101	80	11	1	1		000001	000001		
6	Trave	102	101	11	1	1		000001	000001		
7	Trave	103	80	11	1	1		000001	000001		
8	Trave	102	103	11	1	1		000001	000001		

MODELLAZIONE STRUTTURALE: ELEMENTI SHELL

LEGENDA TABELLA DATI SHELL

Il programma utilizza per la modellazione elementi a tre o quattro nodi denominati in generale shell.

Ogni elemento shell è individuato dai nodi I, J, K, L (L=I per gli elementi a tre nodi).

Ogni elemento è caratterizzato da un insieme di proprietà riportate in tabella che ne completano la modellazione.

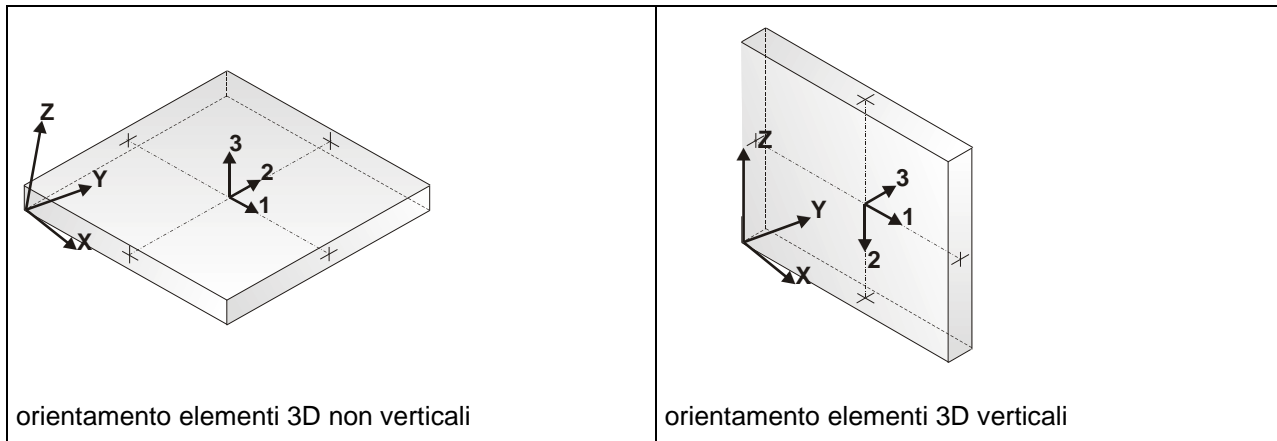

In particolare per ogni elemento viene indicato in tabella:

Elem.	numero dell'elemento
Note	codice di comportamento: <i>Guscio</i> (elemento guscio in elevazione non verticale) <i>Guscio fond.</i> (elemento guscio su suolo elastico) <i>Setto</i> (elemento guscio in elevazione verticale) <i>Membrana</i> (elemento guscio con comportamento membranale)
Nodo I (J, K, L)	numero del nodo I (J, K, L)
Mat.	codice del materiale assegnato all'elemento
Spessore	spessore dell'elemento (costante)
Wink V	costante di sottofondo (coefficiente di Winkler) per la modellazione del suolo elastico verticale
Wink O	costante di sottofondo (coefficiente di Winkler) per la modellazione del suolo elastico orizzontale

Elem.	Note	Nodo I	Nodo J	Nodo K	Nodo L	Mat.	Crit.	Spessore	Svincolo	Wink V	Wink O
								cm		daN/cm3	daN/cm3
1	Guscio fond.	55	48	3	44	1	2	25.0		0.75	0.38
2	Guscio fond.	93	82	12	57	1	2	25.0		0.62	0.31
3	Guscio fond.	66	50	6	42	1	2	25.0		0.68	0.34
4	Guscio fond.	95	94	13	68	1	2	25.0		0.54	0.27
5	Guscio fond.	59	46	10	58	1	2	25.0		0.71	0.36
6	Guscio fond.	69	60	14	70	1	2	25.0		0.59	0.30
7	Guscio fond.	51	49	8	26	1	2	25.0		0.58	0.29
8	Guscio fond.	97	96	15	31	1	2	25.0		0.50	0.25
9	Guscio fond.	62	61	16	32	1	2	25.0		0.53	0.27
10	Guscio fond.	53	52	21	23	1	2	25.0		0.51	0.26
11	Guscio fond.	99	98	19	17	1	2	25.0		0.40	0.20
12	Guscio fond.	64	63	20	18	1	2	25.0		0.45	0.23
13	Guscio fond.	54	53	23	28	1	2	25.0		0.52	0.26
14	Guscio fond.	100	99	17	29	1	2	25.0		0.42	0.21
15	Guscio fond.	65	64	18	30	1	2	25.0		0.47	0.23
16	Guscio fond.	50	54	28	6	1	2	25.0		0.57	0.29
17	Guscio fond.	94	100	29	13	1	2	25.0		0.48	0.24
18	Guscio fond.	60	65	30	14	1	2	25.0		0.52	0.26
19	Guscio fond.	52	51	26	21	1	2	25.0		0.53	0.26
20	Guscio fond.	98	97	31	19	1	2	25.0		0.44	0.22
21	Guscio fond.	63	62	32	20	1	2	25.0		0.48	0.24
22	Guscio fond.	85	84	34	56	1	2	25.0		0.55	0.28
23	Guscio fond.	87	86	36	67	1	2	25.0		0.52	0.26
24	Guscio fond.	89	88	35	37	1	2	25.0		0.46	0.23
25	Guscio fond.	91	90	38	39	1	2	25.0		0.38	0.19
26	Guscio fond.	92	91	39	40	1	2	25.0		0.38	0.19
27	Guscio fond.	86	92	40	36	1	2	25.0		0.44	0.22
28	Guscio fond.	90	89	37	38	1	2	25.0		0.40	0.20
29	Guscio fond.	57	12	48	55	1	2	25.0		0.71	0.36
30	Guscio fond.	68	13	50	66	1	2	25.0		0.59	0.30
31	Guscio fond.	31	15	49	51	1	2	25.0		0.53	0.27
32	Guscio fond.	17	19	52	53	1	2	25.0		0.45	0.23
33	Guscio fond.	29	17	53	54	1	2	25.0		0.47	0.23
34	Guscio fond.	13	29	54	50	1	2	25.0		0.52	0.26
35	Guscio fond.	19	31	51	52	1	2	25.0		0.48	0.24
36	Guscio fond.	49	55	44	8	1	2	25.0		0.68	0.34
37	Guscio fond.	96	93	57	15	1	2	25.0		0.56	0.28
38	Guscio fond.	61	59	58	16	1	2	25.0		0.62	0.31
39	Guscio fond.	88	85	56	35	1	2	25.0		0.52	0.26
40	Guscio fond.	15	57	55	49	1	2	25.0		0.62	0.31
41	Guscio fond.	43	2	46	59	1	2	25.0		0.75	0.38
42	Guscio fond.	41	5	60	69	1	2	25.0		0.68	0.34
43	Guscio fond.	25	7	61	62	1	2	25.0		0.58	0.29
44	Guscio fond.	24	22	63	64	1	2	25.0		0.51	0.26
45	Guscio fond.	27	24	64	65	1	2	25.0		0.52	0.26
46	Guscio fond.	5	27	65	60	1	2	25.0		0.57	0.29
47	Guscio fond.	22	25	62	63	1	2	25.0		0.53	0.26
48	Guscio fond.	7	43	59	61	1	2	25.0		0.68	0.34
49	Guscio fond.	47	66	42	4	1	2	25.0		0.75	0.37
50	Guscio fond.	81	95	68	11	1	2	25.0		0.60	0.30
51	Guscio fond.	45	69	70	9	1	2	25.0		0.68	0.34
52	Guscio fond.	83	87	67	33	1	2	25.0		0.55	0.28

53	Guscio fond.	11	68	66	47	1	2	25.0	0.68	0.34
54	Guscio fond.	1	41	69	45	1	2	25.0	0.75	0.37
55	Setto	127	110	96	97	157	1	5.0		
56	Setto	126	111	88	89	157	1	5.0		
57	Setto	125	109	75	131	157	1	5.0		
58	Setto	123	110	72	130	157	1	5.0		
59	Guscio	132	130	72	129	157	1	5.0		
60	Setto	121	106	76	135	157	1	5.0		
61	Setto	113	104	18	30	157	1	5.0		
62	Setto	120	107	79	139	157	1	5.0		
63	Setto	112	106	17	29	157	1	5.0		
64	Guscio	141	135	76	137	157	1	5.0		
65	Guscio fond.	58	10	84	85	1	2	25.0	0.62	0.31
66	Guscio fond.	70	14	86	87	1	2	25.0	0.54	0.27
67	Guscio fond.	32	16	88	89	1	2	25.0	0.50	0.25
68	Guscio fond.	18	20	90	91	1	2	25.0	0.40	0.20
69	Guscio fond.	30	18	91	92	1	2	25.0	0.42	0.21
70	Guscio fond.	14	30	92	86	1	2	25.0	0.48	0.24
71	Guscio fond.	20	32	89	90	1	2	25.0	0.44	0.22
72	Guscio fond.	16	58	85	88	1	2	25.0	0.56	0.28
73	Guscio fond.	9	70	87	83	1	2	25.0	0.60	0.30
74	Guscio fond.	56	34	82	93	1	2	25.0	0.55	0.28
75	Guscio fond.	67	36	94	95	1	2	25.0	0.52	0.26
76	Guscio fond.	37	35	96	97	1	2	25.0	0.46	0.23
77	Guscio fond.	39	38	98	99	1	2	25.0	0.38	0.19
78	Guscio fond.	40	39	99	100	1	2	25.0	0.38	0.19
79	Guscio fond.	36	40	100	94	1	2	25.0	0.44	0.22
80	Guscio fond.	38	37	97	98	1	2	25.0	0.40	0.20
81	Guscio fond.	35	56	93	96	1	2	25.0	0.52	0.26
82	Guscio fond.	33	67	95	81	1	2	25.0	0.55	0.28
83	Setto	136	77	104	113	157	1	5.0		
84	Setto	94	13	107	120	157	1	5.0		
85	Setto	137	76	106	112	157	1	5.0		
86	Setto	99	17	106	121	157	1	5.0		
87	Setto	38	98	109	125	157	1	5.0		
88	Setto	129	72	110	127	157	1	5.0		
89	Setto	35	96	110	123	157	1	5.0		
90	Setto	128	73	111	126	157	1	5.0		
91	Guscio	122	121	106	112	157	1	5.0		
92	Guscio	120	122	112	107	157	1	5.0		
93	Guscio	119	118	115	116	157	1	5.0		
94	Guscio	117	119	116	114	157	1	5.0		
95	Guscio	113	104	118	119	157	1	5.0		
96	Guscio	108	113	119	117	157	1	5.0		
97	Guscio	116	115	121	122	157	1	5.0		
98	Guscio	114	116	122	120	157	1	5.0		
99	Guscio	126	111	123	124	157	1	5.0		
100	Guscio	105	126	124	125	157	1	5.0		
101	Guscio	124	123	110	127	157	1	5.0		
102	Guscio	125	124	127	109	157	1	5.0		
103	Setto	105	126	89	90	157	1	5.0		
104	Setto	71	128	126	105	157	1	5.0		
105	Setto	109	127	97	98	157	1	5.0		
106	Setto	75	129	127	109	157	1	5.0		
107	Setto	111	123	130	73	157	1	5.0		
108	Setto	88	35	123	111	157	1	5.0		

109	Setto	105	125	131	71	157	1	5.0		
110	Setto	90	38	125	105	157	1	5.0		
111	Guscio	128	73	130	132	157	1	5.0		
112	Guscio	131	132	129	75	157	1	5.0		
113	Guscio	71	128	132	131	157	1	5.0		
114	Setto	104	118	133	77	157	1	5.0		
115	Setto	18	91	118	104	157	1	5.0		
116	Setto	118	115	134	133	157	1	5.0		
117	Setto	91	39	115	118	157	1	5.0		
118	Setto	115	121	135	134	157	1	5.0		
119	Setto	39	99	121	115	157	1	5.0		
120	Setto	108	113	30	14	157	1	5.0		
121	Setto	78	136	113	108	157	1	5.0		
122	Setto	107	112	29	13	157	1	5.0		
123	Setto	79	137	112	107	157	1	5.0		
124	Setto	117	114	138	140	157	1	5.0		
125	Setto	86	36	114	117	157	1	5.0		
126	Setto	114	120	139	138	157	1	5.0		
127	Setto	36	94	120	114	157	1	5.0		
128	Setto	108	117	140	78	157	1	5.0		
129	Setto	14	86	117	108	157	1	5.0		
130	Guscio	136	77	133	142	157	1	5.0		
131	Guscio	142	133	134	74	157	1	5.0		
132	Guscio	74	134	135	141	157	1	5.0		
133	Guscio	139	141	137	79	157	1	5.0		
134	Guscio	78	136	142	140	157	1	5.0		
135	Guscio	140	142	74	138	157	1	5.0		
136	Guscio	138	74	141	139	157	1	5.0		
137	Guscio fond.	44	3	143	152	1	2	25.0	1.04	0.52
138	Guscio fond.	42	6	145	151	1	2	25.0	0.93	0.46
139	Guscio fond.	26	8	146	149	1	2	25.0	0.82	0.41
140	Guscio fond.	23	21	147	148	1	2	25.0	0.68	0.34
141	Guscio fond.	28	23	148	150	1	2	25.0	0.69	0.34
142	Guscio fond.	6	28	150	145	1	2	25.0	0.77	0.39
143	Guscio fond.	21	26	149	147	1	2	25.0	0.70	0.35
144	Guscio fond.	8	44	152	146	1	2	25.0	0.98	0.49
145	Guscio fond.	4	42	151	144	1	2	25.0	1.03	0.52
146	Guscio fond.	162	154	2	43	1	2	25.0	1.04	0.52
147	Guscio fond.	161	155	5	41	1	2	25.0	0.93	0.46
148	Guscio fond.	159	156	7	25	1	2	25.0	0.82	0.41
149	Guscio fond.	158	157	22	24	1	2	25.0	0.68	0.34
150	Guscio fond.	160	158	24	27	1	2	25.0	0.69	0.34
151	Guscio fond.	155	160	27	5	1	2	25.0	0.77	0.39
152	Guscio fond.	157	159	25	22	1	2	25.0	0.70	0.35
153	Guscio fond.	156	162	43	7	1	2	25.0	0.98	0.49
154	Guscio fond.	153	161	41	1	1	2	25.0	1.03	0.52
155	Guscio fond.	48	180	173	3	1	2	25.0	1.04	0.52
156	Guscio fond.	82	164	175	12	1	2	25.0	0.84	0.42
157	Guscio fond.	46	179	174	10	1	2	25.0	0.98	0.49
158	Guscio fond.	84	165	176	34	1	2	25.0	0.73	0.37
159	Guscio fond.	12	175	180	48	1	2	25.0	0.98	0.49
160	Guscio fond.	2	172	179	46	1	2	25.0	1.04	0.52
161	Guscio fond.	10	174	165	84	1	2	25.0	0.84	0.42
162	Guscio fond.	34	176	164	82	1	2	25.0	0.73	0.37
163	Guscio fond.	3	173	168	143	1	2	25.0	1.41	0.71
164	Guscio fond.	154	170	172	2	1	2	25.0	1.41	0.71

165Guscio fond.	167	47	4	182	1	2	25.0	1.03	0.52
166Guscio fond.	169	81	11	184	1	2	25.0	0.81	0.40
167Guscio fond.	166	45	9	183	1	2	25.0	0.93	0.47
168Guscio fond.	171	83	33	163	1	2	25.0	0.73	0.37
169Guscio fond.	184	11	47	167	1	2	25.0	0.93	0.47
170Guscio fond.	181	1	45	166	1	2	25.0	1.03	0.52
171Guscio fond.	183	9	83	171	1	2	25.0	0.81	0.40
172Guscio fond.	163	33	81	169	1	2	25.0	0.73	0.37
173Guscio fond.	182	4	144	177	1	2	25.0	1.41	0.71
174Guscio fond.	178	153	1	181	1	2	25.0	1.41	0.71

MODELLAZIONE DELLE AZIONI

LEGENDA TABELLA DATI AZIONI

Il programma consente l'uso di diverse tipologie di carico (azioni). Le azioni utilizzate nella modellazione sono individuate da una sigla identificativa ed un codice numerico (gli elementi strutturali richiamano quest'ultimo nella propria descrizione). Per ogni azione applicata alla struttura viene di riportato il codice, il tipo e la sigla identificativa. Le tabelle successive dettagliano i valori caratteristici di ogni azione in relazione al tipo. Le tabelle riportano infatti i seguenti dati in relazione al tipo:

1	carico concentrato nodale 6 dati (forza F_x , F_y , F_z , momento M_x , M_y , M_z)
2	spostamento nodale impresso 6 dati (spostamento T_x , T_y , T_z , rotazione R_x , R_y , R_z)
3	carico distribuito globale su elemento tipo trave 7 dati (f_x , f_y , f_z , m_x , m_y , m_z , ascissa di inizio carico) 7 dati (f_x , f_y , f_z , m_x , m_y , m_z , ascissa di fine carico)
4	carico distribuito locale su elemento tipo trave 7 dati (f_1 , f_2 , f_3 , m_1 , m_2 , m_3 , ascissa di inizio carico) 7 dati (f_1 , f_2 , f_3 , m_1 , m_2 , m_3 , ascissa di fine carico)
5	carico concentrato globale su elemento tipo trave 7 dati (F_x , F_y , F_z , M_x , M_y , M_z , ascissa di carico)
6	carico concentrato locale su elemento tipo trave 7 dati (F_1 , F_2 , F_3 , M_1 , M_2 , M_3 , ascissa di carico)
7	variazione termica applicata ad elemento tipo trave 7 dati (variazioni termiche: uniforme, media e differenza in altezza e larghezza al nodo iniziale e finale)
8	carico di pressione uniforme su elemento tipo piastra 1 dato (pressione)
9	carico di pressione variabile su elemento tipo piastra 4 dati (pressione, quota, pressione, quota)
10	variazione termica applicata ad elemento tipo piastra 2 dati (variazioni termiche: media e differenza nello spessore)
11	carico variabile generale su elementi tipo trave e piastra 1 dato descrizione della tipologia 4 dati per segmento (posizione, valore, posizione, valore) la tipologia precisa l'ascissa di definizione, la direzione del carico, la modalità di carico e la larghezza d'influenza per gli elementi tipo trave
12	gruppo di carichi con impronta su piastra 9 dati (numero di ripetizioni in direzione X e Y, valore di ciascun carico, posizione centrale del primo, dimensioni dell'impronta, interasse tra i carichi)

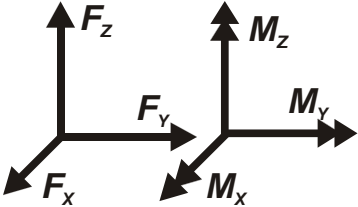
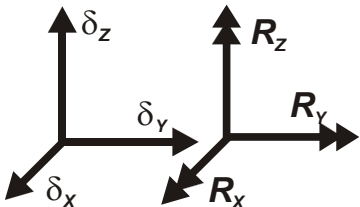
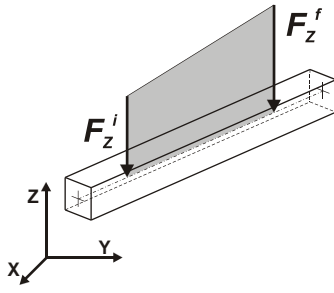
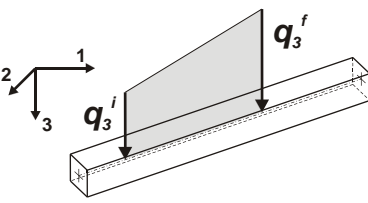
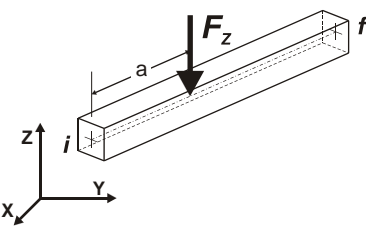
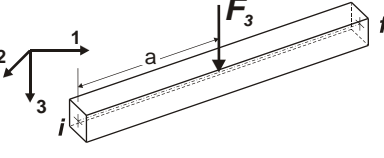
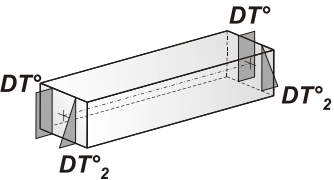
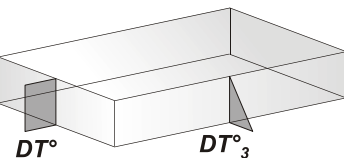
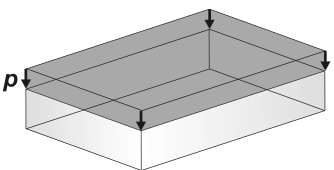
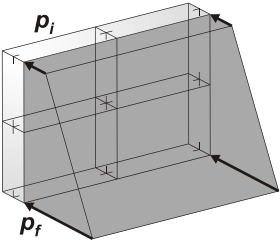
	Carico nodale	concentrato		Spostamento impresso	
	Carico globale	distribuito		Carico locale	distribuito
	Carico globale	concentrato		Carico locale	concentrato
	Carico termico 2D			Carico termico 3D	
	Carico uniforme	pressione		Carico variabile	pressione

Tipo carico variabile generale

Id	Tipo	ascissa	valore	ascissa	valore
		m	daN/ m2	m	daN/ m2
1	VENTILATORE 120X120 - QV:unif - Qz - Area				
	Unif. Qz Area L2=0.0		-834.00		
2	VENTILATORE 80X80 - QV:unif - Qz - Area				
	Unif. Qz Area L2=0.0		-1250.00		

SCHEMATIZZAZIONE DEI CASI DI CARICO

LEGENDA TABELLA CASI DI CARICO

Il programma consente l'applicazione di diverse tipologie di casi di carico.

Sono previsti i seguenti 11 tipi di casi di carico:

	Sigla	Tipo	Descrizione
1	Ggk	A	caso di carico comprensivo del peso proprio struttura
2	Gk	NA	caso di carico con azioni permanenti
3	Qk	NA	caso di carico con azioni variabili
4	Gsk	A	caso di carico comprensivo dei carichi permanenti sui solai e sulle coperture
5	Qsk	A	caso di carico comprensivo dei carichi variabili sui solai
6	Qnk	A	caso di carico comprensivo dei carichi di neve sulle coperture
7	Qtk	SA	caso di carico comprensivo di una variazione termica agente sulla struttura
8	Qvk	NA	caso di carico comprensivo di azioni da vento sulla struttura
9	Esk	SA	caso di carico sismico con analisi statica equivalente
10	Edk	SA	caso di carico sismico con analisi dinamica
11	Etk	NA	caso di carico comprensivo di azioni derivanti dall' incremento di spinta delle terre in condizione sismica
12	Pk	NA	caso di carico comprensivo di azioni derivanti da coazioni, cedimenti e precompressioni

Sono di tipo automatico A (ossia non prevedono introduzione dati da parte dell'utente) i seguenti casi di carico: 1-Ggk; 4-Gsk; 5-Qsk; 6-Qnk.

Sono di tipo semi-automatico SA (ossia prevedono una minima introduzione dati da parte dell'utente) i seguenti casi di carico:

7-Qtk, in quanto richiede solo il valore della variazione termica;

9-Esk e 10-Edk, in quanto richiedono il valore dell'angolo di ingresso del sisma e l'individuazione dei casi di carico partecipanti alla definizione delle masse.

Sono di tipo non automatico NA ossia prevedono la diretta applicazione di carichi generici agli elementi strutturali (si veda il precedente punto Modellazione delle Azioni) i restanti casi di carico.

Nella tabella successiva vengono riportati i casi di carico agenti sulla struttura, con l'indicazione dei dati relativi al caso di carico stesso:

Numero Tipo e Sigla identificativa, Valore di riferimento del caso di carico (se previsto).

In successione, per i casi di carico non automatici, viene riportato l'elenco di nodi ed elementi direttamente caricati con la sigla identificativa del carico.

Per i casi di carico di tipo sismico (9-Esk e 10-Edk), viene riportata la tabella di definizione delle masse: per ogni caso di carico partecipante alla definizione delle masse viene indicata la relativa aliquota (partecipazione) considerata. Si precisa che per i caso di carico 5-Qsk e 6-Qnk la partecipazione è prevista localmente per ogni elemento solaio o

copertura presente nel modello (si confronti il valore Sksol nel capitolo relativo agli elementi solaio) e pertanto la loro partecipazione è di norma pari a uno.

CDC	Tipo	Sigla Id	Note	Per non automatici:
1	Ggk	CDC=Ggk (peso proprio della struttura)		
2	Gsk	CDC=G1sk (permanente solai-coperture)		
3	Qnk	CDC=Qnk (carico da neve)		
4	Edk	CDC=Ed (dinamico SLU) alfa=0.0 (ecc. +)	partecipazione:1.00 per 1 CDC=Ggk (peso proprio della struttura)	
			partecipazione:1.00 per 2 CDC=G1sk (permanente solai-coperture)	
			partecipazione:1.00 per 3 CDC=Qnk (carico da neve)	
5	Edk	CDC=Ed (dinamico SLU) alfa=0.0 (ecc. -)	come precedente CDC sismico	
6	Edk	CDC=Ed (dinamico SLU) alfa=90.00 (ecc. +)	come precedente CDC sismico	
7	Edk	CDC=Ed (dinamico SLU) alfa=90.00 (ecc. -)	come precedente CDC sismico	
8	Edk	CDC=Ed (dinamico SLD) alfa=0.0 (ecc. +)	come precedente CDC sismico	
9	Edk	CDC=Ed (dinamico SLD) alfa=0.0 (ecc. -)	come precedente CDC sismico	
10	Edk	CDC=Ed (dinamico SLD) alfa=90.00 (ecc. +)	come precedente CDC sismico	
11	Edk	CDC=Ed (dinamico SLD) alfa=90.00 (ecc. -)	come precedente CDC sismico	
12	Gk	CDC=G2k (permanente generico n.c.d.) PESO VENTILATORI	Azioni applicate:	Ad elementi:
			[1] VENTILATORE 120X120 - QV:unif - Qz - Area	D3: 91 # 98
			[2] VENTILATORE 80X80 - QV:unif - Qz - Area	D3: 99 # 102

DEFINIZIONE DELLE COMBINAZIONI

LEGENDA TABELLA COMBINAZIONI DI CARICO

Il programma combina i diversi tipi di casi di carico (CDC) secondo le regole previste dalla normativa vigente.

Le combinazioni previste sono destinate al controllo di sicurezza della struttura ed alla verifica degli spostamenti e delle sollecitazioni.

La prima tabella delle combinazioni riportata di seguito comprende le seguenti informazioni: Numero, Tipo, Sigla identificativa. Una seconda tabella riporta il peso nella combinazione assunto per ogni caso di carico.

Ai fini delle verifiche degli stati limite si definiscono le seguenti combinazioni delle azioni:

Combinazione fondamentale SLU

$$\gamma G_1 \cdot G_1 + \gamma G_2 \cdot G_2 + \gamma P \cdot P + \gamma Q_1 \cdot Q_{k1} + \gamma Q_2 \cdot \psi_{02} \cdot Q_{k2} + \gamma Q_3 \cdot \psi_{03} \cdot Q_{k3} + \dots$$

Combinazione caratteristica (rara) SLE

$$G_1 + G_2 + P + Q_{k1} + \psi_{02} \cdot Q_{k2} + \psi_{03} \cdot Q_{k3} + \dots$$

Combinazione frequente SLE

$$G_1 + G_2 + P + \psi_{11} \cdot Q_{k1} + \psi_{22} \cdot Q_{k2} + \psi_{23} \cdot Q_{k3} + \dots$$

Combinazione quasi permanente SLE

$$G_1 + G_2 + P + \psi_{21} \cdot Q_{k1} + \psi_{22} \cdot Q_{k2} + \psi_{23} \cdot Q_{k3} + \dots$$

Combinazione sismica, impiegata per gli stati limite ultimi e di esercizio connessi all'azione sismica E

$$E + G_1 + G_2 + P + \psi_{21} \cdot Q_{k1} + \psi_{22} \cdot Q_{k2} + \dots$$

Combinazione eccezionale, impiegata per gli stati limite connessi alle azioni eccezionali

$$G_1 + G_2 + A_d + P + \psi_{21} \cdot Q_{k1} + \psi_{22} \cdot Q_{k2} + \dots$$

Dove:

NTC 2018 Tabella 2.5.1

Destinazione d'uso/azione	ψ_0	ψ_1	ψ_2
Categoria A residenziali	0,70	0,50	0,30
Categoria B uffici	0,70	0,50	0,30
Categoria C ambienti suscettibili di affollamento	0,70	0,70	0,60
Categoria D ambienti ad uso commerciale	0,70	0,70	0,60
Categoria E biblioteche, archivi, magazzini, ...	1,00	0,90	0,80
Categoria F Rimesse e parcheggi (autoveicoli ≤ 30 kN)	0,70	0,70	0,60
Categoria G Rimesse e parcheggi (autoveicoli > 30 kN)	0,70	0,50	0,30
Categoria H Coperture	0,00	0,00	0,00
Vento	0,60	0,20	0,00
Neve a quota ≤ 1000 m	0,50	0,20	0,00
Neve a quota > 1000 m	0,70	0,50	0,20
Variazioni Termiche	0,60	0,50	0,00

Nelle verifiche possono essere adottati in alternativa due diversi approcci progettuali:

- per l'approccio 1 si considerano due diverse combinazioni di gruppi di coefficienti di sicurezza parziali per le azioni, per i materiali e per la resistenza globale (combinazione 1 con coefficienti A1 e combinazione 2 con coefficienti A2),
- per l'approccio 2 si definisce un'unica combinazione per le azioni, per la resistenza dei materiali e per la resistenza globale (con coefficienti A1).

NTC 2018 Tabella 2.6.I

		Coefficiente γ_f	EQU	A1	A2
Carichi permanenti	Favorevoli	γ_{G1}	0,9	1,0	1,0
	Sfavorevoli		1,1	1,3	1,0
Carichi permanenti non strutturali (Non computamente definiti)	Favorevoli	γ_{G2}	0,8	0,8	0,8
	Sfavorevoli		1,5	1,5	1,3
Carichi variabili	Favorevoli	γ_{Qi}	0,0	0,0	0,0
	Sfavorevoli		1,5	1,5	1,3

Cmb	Tipo	Sigla Id	effetto P-delta
1	SLU	SLU	
2	SLE(r)	SLE_R	
3	SLU	SLV_1_100X_30Y_ex+_ey+	
4	SLU	SLV_2_100X_30Y_ex+_ey-	
5	SLU	SLV_3_100X_30Y_ex-_ey+	
6	SLU	SLV_4_100X_30Y_ex-_ey-	
7	SLU	SLV_5_100X_-30Y_ex+_ey+	
8	SLU	SLV_6_100X_-30Y_ex+_ey-	
9	SLU	SLV_7_100X_-30Y_ex-_ey+	
10	SLU	SLV_8_100X_-30Y_ex-_ey-	
11	SLU	SLV_9_-100X_30Y_ex+_ey+	
12	SLU	SLV_10_-100X_30Y_ex+_ey-	
13	SLU	SLV_11_-100X_30Y_ex-_ey+	
14	SLU	SLV_12_-100X_30Y_ex-_ey-	
15	SLU	SLV_13_-100X_-30Y_ex+_ey+	
16	SLU	SLV_14_-100X_-30Y_ex+_ey-	
17	SLU	SLV_15_-100X_-30Y_ex-_ey+	
18	SLU	SLV_16_-100X_-30Y_ex-_ey-	
19	SLU	SLV_17_30X_100Y_ex+_ey+	
20	SLU	SLV_18_30X_100Y_ex+_ey-	
21	SLU	SLV_19_30X_100Y_ex-_ey+	
22	SLU	SLV_20_30X_100Y_ex-_ey-	
23	SLU	SLV_21_30X_-100Y_ex+_ey+	
24	SLU	SLV_22_30X_-100Y_ex+_ey-	
25	SLU	SLV_23_30X_-100Y_ex-_ey+	
26	SLU	SLV_24_30X_-100Y_ex-_ey-	
27	SLU	SLV_25_-30X_100Y_ex+_ey+	
28	SLU	SLV_26_-30X_100Y_ex+_ey-	

Cmb	Tipo	Sigla Id	effetto P-delta
29	SLU	SLV_27_-30X_100Y_ex-_ey+	
30	SLU	SLV_28_-30X_100Y_ex-_ey-	
31	SLU	SLV_29_-30X_-100Y_ex+_ey+	
32	SLU	SLV_30_-30X_-100Y_ex+_ey-	
33	SLU	SLV_31_-30X_-100Y_ex-_ey+	
34	SLU	SLV_32_-30X_-100Y_ex-_ey-	
35	SLE(sis)	SLD_1_100X_30Y_ex+_ey+	
36	SLE(sis)	SLD_2_100X_30Y_ex+_ey-	
37	SLE(sis)	SLD_3_100X_30Y_ex-_ey+	
38	SLE(sis)	SLD_4_100X_30Y_ex-_ey-	
39	SLE(sis)	SLD_5_100X_-30Y_ex+_ey+	
40	SLE(sis)	SLD_6_100X_-30Y_ex+_ey-	
41	SLE(sis)	SLD_7_100X_-30Y_ex-_ey+	
42	SLE(sis)	SLD_8_100X_-30Y_ex-_ey-	
43	SLE(sis)	SLD_9_-100X_30Y_ex+_ey+	
44	SLE(sis)	SLD_10_-100X_30Y_ex+_ey-	
45	SLE(sis)	SLD_11_-100X_30Y_ex-_ey+	
46	SLE(sis)	SLD_12_-100X_30Y_ex-_ey-	
47	SLE(sis)	SLD_13_-100X_-30Y_ex+_ey+	
48	SLE(sis)	SLD_14_-100X_-30Y_ex+_ey-	
49	SLE(sis)	SLD_15_-100X_-30Y_ex-_ey+	
50	SLE(sis)	SLD_16_-100X_-30Y_ex-_ey-	
51	SLE(sis)	SLD_17_30X_100Y_ex+_ey+	
52	SLE(sis)	SLD_18_30X_100Y_ex+_ey-	
53	SLE(sis)	SLD_19_30X_100Y_ex-_ey+	
54	SLE(sis)	SLD_20_30X_100Y_ex-_ey-	
55	SLE(sis)	SLD_21_30X_-100Y_ex+_ey+	
56	SLE(sis)	SLD_22_30X_-100Y_ex+_ey-	
57	SLE(sis)	SLD_23_30X_-100Y_ex-_ey+	
58	SLE(sis)	SLD_24_30X_-100Y_ex-_ey-	
59	SLE(sis)	SLD_25_-30X_100Y_ex+_ey+	
60	SLE(sis)	SLD_26_-30X_100Y_ex+_ey-	
61	SLE(sis)	SLD_27_-30X_100Y_ex-_ey+	
62	SLE(sis)	SLD_28_-30X_100Y_ex-_ey-	
63	SLE(sis)	SLD_29_-30X_-100Y_ex+_ey+	
64	SLE(sis)	SLD_30_-30X_-100Y_ex+_ey-	
65	SLE(sis)	SLD_31_-30X_-100Y_ex-_ey+	
66	SLE(sis)	SLD_32_-30X_-100Y_ex-_ey-	

Cmb	CDC	CDC	CDC	CDC	CDC	CDC	CDC	CDC	CDC	CDC	CDC	CDC	CDC	CDC
	1/15...	2/16...	3/17...	4/18...	5/19...	6/20...	7/21...	8/22...	9/23...	10/24...	11/25...	12/26...	13/27...	14/28...
1	1.30	1.50	1.50	0.0	0.0	0.0	0.0	0.0	0.0	0.0	0.0	1.50		
2	1.00	1.00	1.00	0.0	0.0	0.0	0.0	0.0	0.0	0.0	0.0	1.00		
3	1.00	1.00	0.0	1.00	0.0	0.30	0.0	0.0	0.0	0.0	0.0	1.00		
4	1.00	1.00	0.0	1.00	0.0	0.0	0.30	0.0	0.0	0.0	0.0	1.00		
5	1.00	1.00	0.0	0.0	1.00	0.30	0.0	0.0	0.0	0.0	0.0	1.00		
6	1.00	1.00	0.0	0.0	1.00	0.0	0.30	0.0	0.0	0.0	0.0	1.00		
7	1.00	1.00	0.0	1.00	0.0	-0.30	0.0	0.0	0.0	0.0	0.0	1.00		
8	1.00	1.00	0.0	1.00	0.0	0.0	-0.30	0.0	0.0	0.0	0.0	1.00		
9	1.00	1.00	0.0	0.0	1.00	-0.30	0.0	0.0	0.0	0.0	0.0	1.00		

Cmb	CDC 1/15...	CDC 2/16...	CDC 3/17...	CDC 4/18...	CDC 5/19...	CDC 6/20...	CDC 7/21...	CDC 8/22...	CDC 9/23...	CDC 10/24...	CDC 11/25...	CDC 12/26...	CDC 13/27...	CDC 14/28...
10	1.00	1.00	0.0	0.0	1.00	0.0	-0.30	0.0	0.0	0.0	0.0	1.00		
11	1.00	1.00	0.0	-1.00	0.0	0.30	0.0	0.0	0.0	0.0	0.0	1.00		
12	1.00	1.00	0.0	-1.00	0.0	0.0	0.30	0.0	0.0	0.0	0.0	1.00		
13	1.00	1.00	0.0	0.0	-1.00	0.30	0.0	0.0	0.0	0.0	0.0	1.00		
14	1.00	1.00	0.0	0.0	-1.00	0.0	0.30	0.0	0.0	0.0	0.0	1.00		
15	1.00	1.00	0.0	-1.00	0.0	-0.30	0.0	0.0	0.0	0.0	0.0	1.00		
16	1.00	1.00	0.0	-1.00	0.0	0.0	-0.30	0.0	0.0	0.0	0.0	1.00		
17	1.00	1.00	0.0	0.0	-1.00	-0.30	0.0	0.0	0.0	0.0	0.0	1.00		
18	1.00	1.00	0.0	0.0	-1.00	0.0	-0.30	0.0	0.0	0.0	0.0	1.00		
19	1.00	1.00	0.0	0.30	0.0	1.00	0.0	0.0	0.0	0.0	0.0	1.00		
20	1.00	1.00	0.0	0.30	0.0	0.0	1.00	0.0	0.0	0.0	0.0	1.00		
21	1.00	1.00	0.0	0.0	0.30	1.00	0.0	0.0	0.0	0.0	0.0	1.00		
22	1.00	1.00	0.0	0.0	0.30	0.0	1.00	0.0	0.0	0.0	0.0	1.00		
23	1.00	1.00	0.0	0.30	0.0	-1.00	0.0	0.0	0.0	0.0	0.0	1.00		
24	1.00	1.00	0.0	0.30	0.0	0.0	-1.00	0.0	0.0	0.0	0.0	1.00		
25	1.00	1.00	0.0	0.0	0.30	-1.00	0.0	0.0	0.0	0.0	0.0	1.00		
26	1.00	1.00	0.0	0.0	0.30	0.0	-1.00	0.0	0.0	0.0	0.0	1.00		
27	1.00	1.00	0.0	-0.30	0.0	1.00	0.0	0.0	0.0	0.0	0.0	1.00		
28	1.00	1.00	0.0	-0.30	0.0	0.0	1.00	0.0	0.0	0.0	0.0	1.00		
29	1.00	1.00	0.0	0.0	-0.30	1.00	0.0	0.0	0.0	0.0	0.0	1.00		
30	1.00	1.00	0.0	0.0	-0.30	0.0	1.00	0.0	0.0	0.0	0.0	1.00		
31	1.00	1.00	0.0	-0.30	0.0	-1.00	0.0	0.0	0.0	0.0	0.0	1.00		
32	1.00	1.00	0.0	-0.30	0.0	0.0	-1.00	0.0	0.0	0.0	0.0	1.00		
33	1.00	1.00	0.0	0.0	-0.30	-1.00	0.0	0.0	0.0	0.0	0.0	1.00		
34	1.00	1.00	0.0	0.0	-0.30	0.0	-1.00	0.0	0.0	0.0	0.0	1.00		
35	1.00	1.00	0.0	0.0	0.0	0.0	0.0	1.00	0.0	0.30	0.0	1.00		
36	1.00	1.00	0.0	0.0	0.0	0.0	0.0	1.00	0.0	0.0	0.30	1.00		
37	1.00	1.00	0.0	0.0	0.0	0.0	0.0	0.0	1.00	0.30	0.0	1.00		
38	1.00	1.00	0.0	0.0	0.0	0.0	0.0	0.0	1.00	0.0	0.30	1.00		
39	1.00	1.00	0.0	0.0	0.0	0.0	0.0	1.00	0.0	-0.30	0.0	1.00		
40	1.00	1.00	0.0	0.0	0.0	0.0	0.0	1.00	0.0	0.0	-0.30	1.00		
41	1.00	1.00	0.0	0.0	0.0	0.0	0.0	0.0	1.00	-0.30	0.0	1.00		
42	1.00	1.00	0.0	0.0	0.0	0.0	0.0	0.0	1.00	0.0	-0.30	1.00		
43	1.00	1.00	0.0	0.0	0.0	0.0	0.0	-1.00	0.0	0.30	0.0	1.00		
44	1.00	1.00	0.0	0.0	0.0	0.0	0.0	-1.00	0.0	0.0	0.30	1.00		
45	1.00	1.00	0.0	0.0	0.0	0.0	0.0	0.0	-1.00	0.30	0.0	1.00		
46	1.00	1.00	0.0	0.0	0.0	0.0	0.0	0.0	-1.00	0.0	0.30	1.00		
47	1.00	1.00	0.0	0.0	0.0	0.0	0.0	-1.00	0.0	-0.30	0.0	1.00		
48	1.00	1.00	0.0	0.0	0.0	0.0	0.0	-1.00	0.0	0.0	-0.30	1.00		
49	1.00	1.00	0.0	0.0	0.0	0.0	0.0	0.0	-1.00	-0.30	0.0	1.00		
50	1.00	1.00	0.0	0.0	0.0	0.0	0.0	0.0	-1.00	0.0	-0.30	1.00		
51	1.00	1.00	0.0	0.0	0.0	0.0	0.0	0.30	0.0	1.00	0.0	1.00		
52	1.00	1.00	0.0	0.0	0.0	0.0	0.0	0.30	0.0	0.0	1.00	1.00		
53	1.00	1.00	0.0	0.0	0.0	0.0	0.0	0.0	0.30	1.00	0.0	1.00		
54	1.00	1.00	0.0	0.0	0.0	0.0	0.0	0.0	0.30	0.0	1.00	1.00		
55	1.00	1.00	0.0	0.0	0.0	0.0	0.0	0.30	0.0	-1.00	0.0	1.00		
56	1.00	1.00	0.0	0.0	0.0	0.0	0.0	0.30	0.0	0.0	-1.00	1.00		
57	1.00	1.00	0.0	0.0	0.0	0.0	0.0	0.0	0.30	-1.00	0.0	1.00		
58	1.00	1.00	0.0	0.0	0.0	0.0	0.0	0.0	0.30	0.0	-1.00	1.00		
59	1.00	1.00	0.0	0.0	0.0	0.0	0.0	-0.30	0.0	1.00	0.0	1.00		
60	1.00	1.00	0.0	0.0	0.0	0.0	0.0	-0.30	0.0	0.0	1.00	1.00		
61	1.00	1.00	0.0	0.0	0.0	0.0	0.0	0.0	-0.30	1.00	0.0	1.00		

Cmb	CDC 1/15...	CDC 2/16...	CDC 3/17...	CDC 4/18...	CDC 5/19...	CDC 6/20...	CDC 7/21...	CDC 8/22...	CDC 9/23...	CDC 10/24...	CDC 11/25...	CDC 12/26...	CDC 13/27...	CDC 14/28...
62	1.00	1.00	0.0	0.0	0.0	0.0	0.0	0.0	-0.30	0.0	1.00	1.00		
63	1.00	1.00	0.0	0.0	0.0	0.0	0.0	-0.30	0.0	-1.00	0.0	1.00		
64	1.00	1.00	0.0	0.0	0.0	0.0	0.0	-0.30	0.0	0.0	-1.00	1.00		
65	1.00	1.00	0.0	0.0	0.0	0.0	0.0	0.0	-0.30	-1.00	0.0	1.00		
66	1.00	1.00	0.0	0.0	0.0	0.0	0.0	0.0	-0.30	0.0	-1.00	1.00		

AZIONE SISMICA

VALUTAZIONE DELL' AZIONE SISMICA

L'azione sismica sulle costruzioni è valutata a partire dalla "pericolosità sismica di base", in condizioni ideali di sito di riferimento rigido con superficie topografica orizzontale.

Allo stato attuale, la pericolosità sismica su reticolo di riferimento nell'intervallo di riferimento è fornita dai dati pubblicati sul sito <http://esse1.mi.ingv.it/>. Per punti non coincidenti con il reticolo di riferimento e periodi di ritorno non contemplati direttamente si opera come indicato nell' allegato alle NTC (rispettivamente media pesata e interpolazione).

L' azione sismica viene definita in relazione ad un periodo di riferimento V_r che si ricava, per ciascun tipo di costruzione, moltiplicandone la vita nominale per il coefficiente d'uso (vedi tabella Parametri della struttura). Fissato il periodo di riferimento V_r e la probabilità di superamento P_{ver} associata a ciascuno degli stati limite considerati, si ottiene il periodo di ritorno T_r e i relativi parametri di pericolosità sismica (vedi tabella successiva):

ag: accelerazione orizzontale massima del terreno;

Fo: valore massimo del fattore di amplificazione dello spettro in accelerazione orizzontale;

T*c: periodo di inizio del tratto a velocità costante dello spettro in accelerazione orizzontale;

Parametri della struttura					
Classe d'uso	Vita V_n [anni]	Coeff. Uso	Periodo V_r [anni]	Tipo di suolo	Categoria topografica
III	50.0	1.5	75.0	B	T1

Individuati su reticolo di riferimento i parametri di pericolosità sismica si valutano i parametri spettrali riportati in tabella: S è il coefficiente che tiene conto della categoria di sottosuolo e delle condizioni topografiche mediante la relazione seguente $S = S_s \cdot S_t$ (3.2.3)

Fo è il fattore che quantifica l'amplificazione spettrale massima, su sito di riferimento rigido orizzontale

Fv è il fattore che quantifica l'amplificazione spettrale massima verticale, in termini di accelerazione orizzontale massima del terreno ag su sito di riferimento rigido orizzontale

Tb è il periodo corrispondente all'inizio del tratto dello spettro ad accelerazione costante.

Tc è il periodo corrispondente all'inizio del tratto dello spettro a velocità costante.

Td è il periodo corrispondente all'inizio del tratto dello spettro a spostamento costante.

Lo spettro di risposta elastico in accelerazione della componente orizzontale del moto sismico, S_e , è definito dalle seguenti espressioni:

$$0 \leq T < T_B \quad S_e(T) = a_g \cdot S \cdot \eta \cdot F_o \cdot \left[\frac{T}{T_B} + \frac{1}{\eta \cdot F_o} \left(1 - \frac{T}{T_B} \right) \right]$$

$$T_B \leq T < T_C \quad S_e(T) = a_g \cdot S \cdot \eta \cdot F_o$$

$$T_C \leq T < T_D \quad S_e(T) = a_g \cdot S \cdot \eta \cdot F_o \cdot \left(\frac{T_C}{T} \right)$$

$$T_D \leq T \quad S_e(T) = a_g \cdot S \cdot \eta \cdot F_o \cdot \left(\frac{T_C \cdot T_D}{T^2} \right)$$

Dove per sottosuolo di categoria **A** i coefficienti S_s e C_c valgono 1; mentre per le categorie di sottosuolo B, C, D, E i coefficienti S_s e C_c vengono calcolati mediante le espressioni riportate nella seguente Tabella

Categoria sottosuolo	S_s	C_c
A	1,00	1,00
B	$1,00 \leq 1,40 - 0,40 \cdot F_o \cdot \frac{a_g}{g} \leq 1,20$	$1,10 \cdot (T_c^*)^{-0,20}$
C	$1,00 \leq 1,70 - 0,60 \cdot F_o \cdot \frac{a_g}{g} \leq 1,50$	$1,05 \cdot (T_c^*)^{-0,33}$
D	$0,90 \leq 2,40 - 1,50 \cdot F_o \cdot \frac{a_g}{g} \leq 1,80$	$1,25 \cdot (T_c^*)^{-0,50}$
E	$1,00 \leq 2,00 - 1,10 \cdot F_o \cdot \frac{a_g}{g} \leq 1,60$	$1,15 \cdot (T_c^*)^{-0,40}$

Per tenere conto delle condizioni topografiche e in assenza di specifiche analisi di risposta sismica locale, si utilizzano i valori del coefficiente topografico S_T riportati nella seguente Tabella

Categoria topografica	Ubicazione dell'opera o dell'intervento	S_T
T1	-	1,0
T2	In corrispondenza della sommità del pendio	1,2
T3	In corrispondenza della cresta di un rilievo con pendenza media minore o uguale a 30°	1,2
T4	In corrispondenza della cresta di un rilievo con pendenza media maggiore di 30°	1,4

Lo spettro di risposta elastico in accelerazione della componente verticale del moto sismico, S_{ve} , è definito dalle espressioni:

$$0 \leq T < T_B \quad S_{ve}(T) = a_g \cdot S \cdot \eta \cdot F_v \cdot \left[\frac{T}{T_B} + \frac{1}{\eta \cdot F_o} \left(1 - \frac{T}{T_B} \right) \right]$$

$$T_B \leq T < T_C \quad S_{ve}(T) = a_g \cdot S \cdot \eta \cdot F_v$$

$$T_C \leq T < T_D \quad S_{ve}(T) = a_g \cdot S \cdot \eta \cdot F_v \cdot \left(\frac{T_C}{T} \right)$$

$$T_D \leq T \quad S_{ve}(T) = a_g \cdot S \cdot \eta \cdot F_v \cdot \left(\frac{T_C \cdot T_D}{T^2} \right)$$

I valori di S_s , T_B , T_C e T_D , sono riportati nella seguente Tabella

Categoria di sottosuolo	S_s	T_B	T_C	T_D
A, B, C, D, E	1,0	0,05 s	0,15 s	1,0 s

Id nodo	Longitudine	Latitudine	Distanza
			Km
Loc.	15.631	40.075	
36551	15.580	40.066	4.554
36552	15.645	40.064	1.745
36330	15.647	40.114	4.423
36329	15.581	40.115	6.131

SL	Pver	Tr	ag	Fo	T*c
		Anni	g		sec
SLO	81.0	45.2	0.052	2.411	0.306
SLD	63.0	75.4	0.066	2.453	0.332
SLV	10.0	711.8	0.177	2.442	0.433
SLC	5.0	1462.2	0.235	2.447	0.446

SL	ag	S	Fo	Fv	Tb	Tc	Td
	g				sec	sec	sec
SLO	0.052	1.200	2.411	0.742	0.142	0.427	1.808
SLD	0.066	1.200	2.453	0.849	0.152	0.455	1.863
SLV	0.177	1.200	2.442	1.386	0.188	0.563	2.307
SLC	0.235	1.170	2.447	1.602	0.192	0.577	2.540

Modo	Frequenza	Periodo	X M efficace x g	%	Y M efficace x g	%	Z M efficace x g	%	RZ M efficace x g	%
	1/sec	sec	daN		daN		daN		daN m2	
1	7.95	0.13	0.0	0	315.6	99	0.0	0	3.14e-02	26
2	8.39	0.12	316.0	99	0.0	0	1.30e-05	0	0.0	0
3	9.45	0.11	0.0	0	1.25e-03	0	0.0	0	8.64e-02	73
4	20.35	0.05	0.0	0	1.07e-05	0	0.0	0	5.06e-04	0
5	48.03	0.02	0.6	0	0.0	0	6.28e-02	0	0.0	0
6	57.10	0.02	2.01e-04	0	0.0	0	316.5	99	0.0	0

RISULTATI ANALISI SISMICHE

LEGENDA TABELLA ANALISI SISMICHE

Il programma consente l'analisi di diverse configurazioni sismiche.

Sono previsti, infatti, i seguenti casi di carico:

9. Esk caso di carico sismico con analisi statica equivalente

10. Edk caso di carico sismico con analisi dinamica

Ciascun caso di carico è caratterizzato da un angolo di ingresso e da una configurazione di masse determinante la forza sismica complessiva (si rimanda al capitolo relativo ai casi di carico per chiarimenti inerenti questo aspetto).

Nella colonna Note, in funzione della norma in uso sono riportati i parametri fondamentali che caratterizzano l'azione sismica: in particolare possono essere presenti i seguenti valori:

Angolo di ingresso	Angolo di ingresso dell'azione sismica orizzontale
Fattore di importanza	Fattore di importanza dell'edificio, in base alla categoria di appartenenza
Zona sismica	Zona sismica
Accelerazione ag	Accelerazione orizzontale massima sul suolo
Categoria suolo	Categoria di profilo stratigrafico del suolo di fondazione
Fattore q	Fattore di struttura/di comportamento. Dipendente dalla tipologia strutturale
Amplificazione ND	Coefficiente di amplificazione q/q_{ND} delle azioni sismiche (solo per elementi progettati in campo non dissipativo)
Fattore di sito S	Fattore dipendente dalla stratigrafia e dal profilo topografico
Classe di duttilità CD	Classe di duttilità della struttura – "A" duttilità alta, "B" duttilità bassa
Fattore di riduzione SLD	Fattore di riduzione dello spettro elastico per lo stato limite di danno
Periodo proprio T1	Periodo proprio di vibrazione della struttura
Coefficiente Lambda	Coefficiente dipendente dal periodo proprio T1 e dal numero di piani della struttura
Ordinata spettro Sd(T1)	Valore delle ordinate dello spettro di progetto per lo stato limite ultimo, componente orizzontale (verticale Svd)
Ordinata spettro Se(T1)	Valore delle ordinate dello spettro elastico ridotta del fattore SLD per lo stato limite di danno, componente orizzontale (verticale Sve)
Ordinata spettro S (Tb-Tc)	Valore dell'ordinata dello spettro in uso nel tratto costante
N° di modi considerati	Numero di modi di vibrare della struttura considerati nell'analisi dinamica

Nel caso di elementi progettati in campo non dissipativo vengono adottate le sollecitazioni calcolate con un fattore q_{ND} ricavato come da 7.3.2 in funzione del fattore di comportamento q utilizzato per la struttura: $1 < q_{ND} = 2/3 * q < 1.5$
 Il coefficiente di amplificazione delle azioni sismiche rispetto alle azioni calcolate con il fattore di comportamento globale viene indicato nelle relative tabelle.

Per ciascun caso di carico sismico viene riportato l'insieme di dati sotto riportati (le masse sono espresse in unità di forza):

- a) analisi sismica statica equivalente:
 - quota, posizione del centro di applicazione e azione orizzontale risultante, posizione del baricentro delle rigidezze, rapporto r/L_s (per strutture a nucleo), indici di regolarità e/r secondo EC8 4.2.3.2
 - azione sismica complessiva
- b) analisi sismica dinamica con spettro di risposta:
 - quota, posizione del centro di massa e massa risultante, posizione del baricentro delle rigidezze, rapporto r/L_s (per strutture a nucleo) , indici di regolarità e/r secondo EC8 4.2.3.2
 - frequenza, periodo, accelerazione spettrale, massa eccitata nelle tre direzioni globali per tutti i modi
 - massa complessiva ed aliquota di massa complessiva eccitata.

Per ciascuna combinazione sismica definita SLD o SLO viene riportato il livello di deformazione η_T (dr) degli elementi strutturali verticali. Per semplicità di consultazione il livello è espresso anche in unità $1000 * \eta_T / h$ da confrontare direttamente con i valori forniti nella norma (es. 5 per edifici con tamponamenti collegati rigidamente alla struttura, 10.0 per edifici con tamponamenti collegati elasticamente, 3 per edifici in muratura ordinaria, 4 per edifici in muratura armata).

Qualora si applichi il D.M. 96 (vedi NOTA sul capitolo "normativa di riferimento") l'analisi sismica dinamica può essere comprensiva di sollecitazione verticale contemporanea a quella orizzontale, nel qual caso è effettuata una sovrapposizione degli effetti in ragione della radice dei quadrati degli effetti stessi. Per ciascuna combinazione sismica - analisi effettuate con il D.M. 96 (vedi NOTA sul capitolo "normativa di riferimento") - viene riportato il livello di deformazione η_T , η_P e η_D degli elementi strutturali verticali. Per semplicità di consultazione il livello è espresso in unità $1000 * \eta_T / h$ da confrontare direttamente con il valore 2 o 4 per la verifica.

Per gli edifici sismicamente isolati si riportano di seguito le verifiche condotte sui dispositivi di isolamento. Le verifiche sono effettuate secondo la circolare n.7/2019 del C.S.LL.PP nelle combinazioni in SLC come previsto dal DM 17-01-2018. Per ogni combinazione è riportato il codice di verifica ed i valori utilizzati per la verifica: spostamento dE , area ridotta e dimensione A_2 , azione verticale, deformazioni di taglio dell'elastomero e tensioni nell'acciaio.

In particolare la tabella, per ogni combinazione di calcolo, riporta:

Nodo	Nodo di appoggio dell' isolatore
Cmb	Combinazione oggetto della verifica
Verif.	Codice di verifica ok – verifica positiva , NV – verifica negativa, ND – verifica non completata
dE	Spostamento relativo tra le due facce combinato con la regola del 30%
Ang fi	Angolo utilizzato per il calcolo dell' area ridotta A_r (per dispositivi circolari)
V	Azione verticale agente
A_r	Area ridotta efficace
Dim A_2	Dimensione utile per il calcolo della deformazione per rotazione
Sig s	Tensione nell' inserto in acciaio

Gam c(a,s,t)	Deformazioni di taglio dell' elastomero
Vcr	Carico critico per instabilità

Affinché la verifica sia positiva deve essere:

- 1) $V > 0$
- 2) $\text{Sig } s < f_{yk}$
- 3) $\text{Gam } t < 5$
- 4) $\text{Gam } s < \text{Gam} * (\text{caratteristica dell' elastomero})$
- 5) $\text{Gam } s < 2$
- 6) $V < 0.5 V_{cr}$

CDC	Tipo	Sigla Id	Note
4	Edk	CDC=Ed (dinamico SLU) alfa=0.0 (ecc. +)	
			categoria suolo: B
			fattore di sito S = 1.200
			ordinata spettro (tratto Tb-Tc) = 0.518 g
			angolo di ingresso:0.0
			eccentricità aggiuntiva: positiva
			periodo proprio T1: 0.120 s
			fattore q: 1.000
			amplificazione ND (non dissipativi): 1.000
			fattore per spost. mu d: 1.000
			classe di duttilità CD: ND
			numero di modi considerati: 12
			combinaz. modale: CQC

Quota	M Sismica x g	Pos. GX	Pos. GY	E agg. X-X	E agg. Y-Y	Pos. KX	Pos. KY	(r/Ls)^2	rapp. ex/rx	rapp. ey/ry
m	daN	m	m	m	m	m	m			
2.00	316.54	1.60	0.80	0.0	-0.07	1.60	0.80	3.000	0.0	0.0
Risulta	316.54									

Modo	Frequenza	Periodo	Acc. Spettrale	M efficace X x g	%	M efficace Y x g	%	M efficace Z x g	%	Energia	Energia x v
	Hz	sec	g	daN		daN		daN			
1	7.945	0.126	0.417	9.06e-05	2.86e-05	315.60	99.7	0.0	0.0	0.0	0.0
2	8.366	0.120	0.406	310.85	98.2	1.94e-04	6.11e-05	1.26e-05	3.99e-06	0.0	0.0
3	9.473	0.106	0.384	5.01	1.6	1.19e-03	3.77e-04	0.0	0.0	0.0	0.0
4	20.453	0.049	0.292	0.11	3.54e-02	1.04e-05	3.29e-06	0.0	0.0	0.0	0.0
5	48.035	0.021	0.246	0.56	0.2	0.0	0.0	0.06	1.98e-02	0.0	0.0
6	57.096	0.018	0.241	2.01e-04	6.36e-05	0.0	0.0	316.47	100.0	0.0	0.0
7	60.620	0.016	0.239	0.0	0.0	0.93	0.3	0.0	0.0	0.0	0.0
8	186.532	0.005	0.221	0.0	0.0	1.14e-06	0.0	0.0	0.0	0.0	0.0

Modo	Frequenza	Periodo	Acc. Spettrale	M efficace X x g	%	M efficace Y x g	%	M efficace Z x g	%	Energia	Energia x v
Risulta				316.54		316.54		316.54			
In percentuale				100.00		100.00		100.00			

CDC	Tipo	Sigla Id	Note
6	Edk	CDC=Ed (dinamico SLU) alfa=90.00 (ecc. +)	
			categoria suolo: B
			fattore di sito S = 1.200
			ordinata spettro (tratto Tb-Tc) = 0.518 g
			angolo di ingresso:90.00
			eccentricità aggiuntiva: positiva
			periodo proprio T1: 0.127 s
			fattore q: 1.000
			amplificazione ND (non dissipativi): 1.000
			fattore per spost. mu d: 1.000
			classe di duttilità CD: ND
			numero di modi considerati: 12
			combinaz. modale: CQC

Quota	M Sismica x g	Pos. GX	Pos. GY	E agg. X-X	E agg. Y-Y	Pos. KX	Pos. KY	(r/Ls)^2	rapp. ex/rx	rapp. ey/ry
m	daN	m	m	m	m	m	m			
2.00	316.54	1.60	0.80	0.15	0.0	1.60	0.80	3.000	0.0	0.0
Risulta	316.54									

Modo	Frequenza	Periodo	Acc. Spettrale	M efficace X x g	%	M efficace Y x g	%	M efficace Z x g	%	Energia	Energia x v
	Hz	sec	g	daN		daN		daN			
1	7.866	0.127	0.419	0.0	0.0	302.54	95.6	0.0	0.0	0.0	0.0
2	8.392	0.119	0.406	315.97	99.8	0.0	0.0	1.30e-05	4.11e-06	0.0	0.0
3	9.583	0.104	0.382	0.0	0.0	13.05	4.1	0.0	0.0	0.0	0.0
4	20.360	0.049	0.292	0.0	0.0	0.01	4.18e-03	0.0	0.0	0.0	0.0
5	48.034	0.021	0.246	0.56	0.2	0.0	0.0	0.06	1.98e-02	0.0	0.0
6	57.096	0.018	0.241	2.01e-04	6.35e-05	0.0	0.0	316.47	100.0	0.0	0.0
7	60.621	0.016	0.239	0.0	0.0	0.94	0.3	0.0	0.0	0.0	0.0
8	186.532	0.005	0.221	0.0	0.0	1.13e-06	0.0	0.0	0.0	0.0	0.0
9	305.411	0.003	0.217	0.0	0.0	0.0	0.0	2.54e-06	0.0	0.0	0.0
10	305.718	0.003	0.217	0.0	0.0	0.0	0.0	0.0	0.0	0.0	0.0
11	426.199	0.002	0.216	0.0	0.0	0.0	0.0	0.0	0.0	0.0	0.0
12	471.181	0.002	0.215	0.0	0.0	0.0	0.0	0.0	0.0	0.0	0.0
Risulta				316.54		316.54		316.54			
In percentuale				100.00		100.00		100.00			

CDC	Tipo	Sigla Id	Note
7	Edk	CDC=Ed (dinamico SLU) alfa=90.00 (ecc. -)	
			categoria suolo: B
			fattore di sito S = 1.200
			ordinata spettro (tratto Tb-Tc) = 0.518 g
			angolo di ingresso:90.00
			eccentricità aggiuntiva: negativa
			periodo proprio T1: 0.127 s
			fattore q: 1.000
			amplificazione ND (non dissipativi): 1.000
			fattore per spost. mu d: 1.000
			classe di duttilità CD: ND
			numero di modi considerati: 12
			combinaz. modale: CQC

Quota	M Sismica x g	Pos. GX	Pos. GY	E agg. X-X	E agg. Y-Y	Pos. KX	Pos. KY	(r/Ls)^2	rapp. ex/rx	rapp. ey/ry
m	daN	m	m	m	m	m	m			
2.00	316.54	1.60	0.80	-0.15	0.0	1.60	0.80	3.000	0.0	0.0
Risulta	316.54									

Modo	Frequenza	Periodo	Acc. Spettrale	M efficace X % x g	M efficace Y % x g	M efficace Z % x g	Energia	Energia x v			
	Hz	sec	g	daN	daN	daN					
1	7.868	0.127	0.419	0.0	0.0	302.92	95.7	0.0	0.0	0.0	0.0
2	8.392	0.119	0.406	315.97	99.8	0.0	0.0	1.30e-05	4.11e-06	0.0	0.0
3	9.580	0.104	0.382	0.0	0.0	12.67	4.0	0.0	0.0	0.0	0.0
4	20.360	0.049	0.292	0.0	0.0	0.01	3.71e-03	0.0	0.0	0.0	0.0
5	48.034	0.021	0.246	0.56	0.2	0.0	0.0	0.06	1.98e-02	0.0	0.0
6	57.096	0.018	0.241	2.01e-04	6.35e-05	0.0	0.0	316.47	100.0	0.0	0.0
7	60.621	0.016	0.239	0.0	0.0	0.94	0.3	0.0	0.0	0.0	0.0
8	186.532	0.005	0.221	0.0	0.0	1.15e-06	0.0	0.0	0.0	0.0	0.0
9	305.411	0.003	0.217	0.0	0.0	0.0	0.0	2.54e-06	0.0	0.0	0.0
10	305.718	0.003	0.217	0.0	0.0	0.0	0.0	0.0	0.0	0.0	0.0
11	426.199	0.002	0.216	0.0	0.0	0.0	0.0	0.0	0.0	0.0	0.0
12	471.181	0.002	0.215	0.0	0.0	0.0	0.0	0.0	0.0	0.0	0.0
Risulta				316.54		316.54		316.54			
In percentuale				100.00		100.00		100.00			

CDC	Tipo	Sigla Id	Note
8	Edk	CDC=Ed (dinamico SLD) alfa=0.0 (ecc. +)	
			categoria suolo: B
			fattore di sito S = 1.200

CDC	Tipo	Sigla Id	Note
			ordinata spettro (tratto Tb-Tc) = 0.194 g
			angolo di ingresso:0.0
			eccentricità aggiuntiva: positiva
			periodo proprio T1: 0.120 s
			numero di modi considerati: 12
			combinaz. modale: CQC

Quota	M Sismica x g	Pos. GX	Pos. GY	E agg. X-X	E agg. Y-Y	Pos. KX	Pos. KY	(r/Ls)^2	rapp. ex/rx	rapp. ey/ry
m	daN	m	m	m	m	m	m			
2.00	316.54	1.60	0.80	0.0	-0.07	1.60	0.80	3.000	0.0	0.0
Risulta	316.54									

Modo	Frequenza	Periodo	Acc. Spettrale	M efficace X % x g	M efficace Y % x g	M efficace Z % x g	Energia	Energia x v			
	Hz	sec	g	daN	daN	daN					
1	7.945	0.126	0.174	9.06e-05	2.86e-05	315.60	99.7	0.0	0.0	0.0	0.0
2	8.366	0.120	0.169	310.85	98.2	1.94e-04	6.11e-05	1.26e-05	3.99e-06	0.0	0.0
3	9.473	0.106	0.159	5.01	1.6	1.19e-03	3.77e-04	0.0	0.0	0.0	0.0
4	20.453	0.049	0.116	0.11	3.54e-02	1.04e-05	3.29e-06	0.0	0.0	0.0	0.0
5	48.035	0.021	0.095	0.56	0.2	0.0	0.0	0.06	1.98e-02	0.0	0.0
6	57.096	0.018	0.092	2.01e-04	6.36e-05	0.0	0.0	316.47	100.0	0.0	0.0
7	60.620	0.016	0.091	0.0	0.0	0.93	0.3	0.0	0.0	0.0	0.0
8	186.532	0.005	0.083	0.0	0.0	1.14e-06	0.0	0.0	0.0	0.0	0.0
9	291.344	0.003	0.082	0.0	0.0	0.0	0.0	1.42e-06	0.0	0.0	0.0
10	322.094	0.003	0.081	0.0	0.0	0.0	0.0	1.12e-06	0.0	0.0	0.0
11	446.979	0.002	0.081	0.0	0.0	0.0	0.0	0.0	0.0	0.0	0.0
12	447.024	0.002	0.081	0.0	0.0	0.0	0.0	0.0	0.0	0.0	0.0
Risulta				316.54		316.54		316.54			
In percentuale				100.00		100.00		100.00			

CDC	Tipo	Sigla Id	Note
9	Edk	CDC=Ed (dinamico SLD) alfa=0.0 (ecc. -)	
			categoria suolo: B
			fattore di sito S = 1.200
			ordinata spettro (tratto Tb-Tc) = 0.194 g
			angolo di ingresso:0.0
			eccentricità aggiuntiva: negativa
			periodo proprio T1: 0.120 s
			numero di modi considerati: 12
			combinaz. modale: CQC

Modo	Frequenza	Periodo	Acc. Spettrale	M efficace X x g	%	M efficace Y x g	%	M efficace Z x g	%	Energia	Energia x v
	Hz	sec	g	daN		daN		daN			
1	7.866	0.127	0.175	0.0	0.0	302.54	95.6	0.0	0.0	0.0	0.0
2	8.392	0.119	0.169	315.97	99.8	0.0	0.0	1.30e-05	4.11e-06	0.0	0.0
3	9.583	0.104	0.158	0.0	0.0	13.05	4.1	0.0	0.0	0.0	0.0
4	20.360	0.049	0.116	0.0	0.0	0.01	4.18e-03	0.0	0.0	0.0	0.0
5	48.034	0.021	0.095	0.56	0.2	0.0	0.0	0.06	1.98e-02	0.0	0.0
6	57.096	0.018	0.092	2.01e-04	6.35e-05	0.0	0.0	316.47	100.0	0.0	0.0
7	60.621	0.016	0.091	0.0	0.0	0.94	0.3	0.0	0.0	0.0	0.0
8	186.532	0.005	0.083	0.0	0.0	1.13e-06	0.0	0.0	0.0	0.0	0.0
9	305.411	0.003	0.081	0.0	0.0	0.0	0.0	2.54e-06	0.0	0.0	0.0
10	305.718	0.003	0.081	0.0	0.0	0.0	0.0	0.0	0.0	0.0	0.0
11	426.199	0.002	0.081	0.0	0.0	0.0	0.0	0.0	0.0	0.0	0.0
12	471.181	0.002	0.081	0.0	0.0	0.0	0.0	0.0	0.0	0.0	0.0
Risulta				316.54		316.54		316.54			
In percentuale				100.00		100.00		100.00			

CDC	Tipo	Sigla Id	Note
11	Edk	CDC=Ed (dinamico SLD) alfa=90.00 (ecc. -)	
			categoria suolo: B
			fattore di sito S = 1.200
			ordinata spettro (tratto Tb-Tc) = 0.194 g
			angolo di ingresso:90.00
			eccentricità aggiuntiva: negativa
			periodo proprio T1: 0.127 s
			numero di modi considerati: 12
			combinaz. modale: CQC

Quota	M Sismica x g	Pos. GX	Pos. GY	E agg. X-X	E agg. Y-Y	Pos. KX	Pos. KY	(r/Ls)^2	rapp. ex/rx	rapp. ey/ry
m	daN	m	m	m	m	m	m			
2.00	316.54	1.60	0.80	-0.15	0.0	1.60	0.80	3.000	0.0	0.0
Risulta	316.54									

Modo	Frequenza	Periodo	Acc. Spettrale	M efficace X x g	%	M efficace Y x g	%	M efficace Z x g	%	Energia	Energia x v
	Hz	sec	g	daN		daN		daN			
1	7.868	0.127	0.175	0.0	0.0	302.92	95.7	0.0	0.0	0.0	0.0
2	8.392	0.119	0.169	315.97	99.8	0.0	0.0	1.30e-05	4.11e-06	0.0	0.0
3	9.580	0.104	0.158	0.0	0.0	12.67	4.0	0.0	0.0	0.0	0.0
4	20.360	0.049	0.116	0.0	0.0	0.01	3.71e-03	0.0	0.0	0.0	0.0
5	48.034	0.021	0.095	0.56	0.2	0.0	0.0	0.06	1.98e-02	0.0	0.0
6	57.096	0.018	0.092	2.01e-04	6.35e-05	0.0	0.0	316.47	100.0	0.0	0.0
7	60.621	0.016	0.091	0.0	0.0	0.94	0.3	0.0	0.0	0.0	0.0

Modo	Frequenza	Periodo	Acc. Spettrale	M efficace X x g	%	M efficace Y x g	%	M efficace Z x g	%	Energia	Energia x v
8	186.532	0.005	0.083	0.0	0.0	1.15e-06	0.0	0.0	0.0	0.0	0.0
9	305.411	0.003	0.081	0.0	0.0	0.0	0.0	2.54e-06	0.0	0.0	0.0
10	305.718	0.003	0.081	0.0	0.0	0.0	0.0	0.0	0.0	0.0	0.0
11	426.199	0.002	0.081	0.0	0.0	0.0	0.0	0.0	0.0	0.0	0.0
12	471.181	0.002	0.081	0.0	0.0	0.0	0.0	0.0	0.0	0.0	0.0
Risulta				316.54		316.54		316.54			
In percentuale				100.00		100.00		100.00			

Cmb	Pilas. 1000 etaT/h	etaT			Pilas. 1000 etaT/h	etaT			Pilas. 1000 etaT/h	etaT		
		inter. h	cm	cm		inter. h	cm	cm		inter. h	cm	cm
35	1	0.33	0.07	200.0	2	0.30	0.06	200.0	3	0.34	0.07	200.0
	4	0.37	0.07	200.0								
36	1	0.33	0.07	200.0	2	0.32	0.06	200.0	3	0.34	0.07	200.0
	4	0.34	0.07	200.0								
37	1	0.34	0.07	200.0	2	0.34	0.07	200.0	3	0.33	0.07	200.0
	4	0.32	0.06	200.0								
38	1	0.34	0.07	200.0	2	0.37	0.07	200.0	3	0.33	0.07	200.0
	4	0.30	0.06	200.0								
39	1	0.32	0.06	200.0	2	0.33	0.07	200.0	3	0.34	0.07	200.0
	4	0.34	0.07	200.0								
40	1	0.30	0.06	200.0	2	0.33	0.07	200.0	3	0.37	0.07	200.0
	4	0.34	0.07	200.0								
41	1	0.37	0.07	200.0	2	0.34	0.07	200.0	3	0.30	0.06	200.0
	4	0.33	0.07	200.0								
42	1	0.34	0.07	200.0	2	0.34	0.07	200.0	3	0.32	0.06	200.0
	4	0.33	0.07	200.0								
43	1	0.26	0.05	200.0	2	0.27	0.05	200.0	3	0.28	0.06	200.0
	4	0.27	0.05	200.0								
44	1	0.23	0.05	200.0	2	0.27	0.05	200.0	3	0.30	0.06	200.0
	4	0.27	0.05	200.0								
45	1	0.30	0.06	200.0	2	0.27	0.05	200.0	3	0.23	0.05	200.0
	4	0.27	0.05	200.0								
46	1	0.28	0.06	200.0	2	0.27	0.05	200.0	3	0.26	0.05	200.0
	4	0.27	0.05	200.0								
47	1	0.27	0.05	200.0	2	0.23	0.05	200.0	3	0.27	0.05	200.0
	4	0.30	0.06	200.0								
48	1	0.27	0.05	200.0	2	0.26	0.05	200.0	3	0.27	0.05	200.0
	4	0.28	0.06	200.0								
49	1	0.27	0.05	200.0	2	0.28	0.06	200.0	3	0.27	0.05	200.0
	4	0.26	0.05	200.0								
50	1	0.27	0.05	200.0	2	0.30	0.06	200.0	3	0.27	0.05	200.0
	4	0.23	0.05	200.0								
51	1	0.40	0.08	200.0	2	0.28	0.06	200.0	3	0.30	0.06	200.0
	4	0.41	0.08	200.0								
52	1	0.31	0.06	200.0	2	0.39	0.08	200.0	3	0.38	0.08	200.0
	4	0.30	0.06	200.0								
53	1	0.38	0.08	200.0	2	0.30	0.06	200.0	3	0.31	0.06	200.0
	4	0.39	0.08	200.0								
54	1	0.30	0.06	200.0	2	0.41	0.08	200.0	3	0.39	0.08	200.0

	4	0.28	0.06	200.0								
55	1	0.39	0.08	200.0	2	0.31	0.06	200.0	3	0.30	0.06	200.0
	4	0.38	0.08	200.0								
56	1	0.28	0.06	200.0	2	0.39	0.08	200.0	3	0.41	0.08	200.0
	4	0.30	0.06	200.0								
57	1	0.41	0.08	200.0	2	0.30	0.06	200.0	3	0.28	0.06	200.0
	4	0.40	0.08	200.0								
58	1	0.30	0.06	200.0	2	0.38	0.08	200.0	3	0.39	0.08	200.0
	4	0.31	0.06	200.0								
59	1	0.37	0.07	200.0	2	0.29	0.06	200.0	3	0.28	0.06	200.0
	4	0.37	0.07	200.0								
60	1	0.26	0.05	200.0	2	0.38	0.08	200.0	3	0.39	0.08	200.0
	4	0.27	0.05	200.0								
61	1	0.39	0.08	200.0	2	0.27	0.05	200.0	3	0.26	0.05	200.0
	4	0.39	0.08	200.0								
62	1	0.28	0.06	200.0	2	0.37	0.07	200.0	3	0.37	0.07	200.0
	4	0.29	0.06	200.0								
63	1	0.39	0.08	200.0	2	0.26	0.05	200.0	3	0.27	0.05	200.0
	4	0.39	0.08	200.0								
64	1	0.29	0.06	200.0	2	0.37	0.07	200.0	3	0.37	0.07	200.0
	4	0.28	0.06	200.0								
65	1	0.37	0.07	200.0	2	0.28	0.06	200.0	3	0.29	0.06	200.0
	4	0.37	0.07	200.0								
66	1	0.27	0.05	200.0	2	0.39	0.08	200.0	3	0.38	0.08	200.0
	4	0.26	0.05	200.0								

Cmb **1000 etaT/h**
0.41

RISULTATI NODALI

LEGENDA RISULTATI NODALI

Il controllo dei risultati delle analisi condotte, per quanto concerne i nodi strutturali, è possibile in relazione alle tabelle sottoriportate.

Una prima tabella riporta infatti per ogni nodo e per ogni combinazione (o caso di carico) gli spostamenti nodali.

Una seconda tabella riporta per ogni nodo a cui sia associato un vincolo rigido e/o elastico o una fondazione speciale e per ogni combinazione (o caso di carico) i valori delle azioni esercitate dalla struttura sui vincoli (reazioni vincolari cambiate di segno).

Una terza tabella, infine riassume per ogni nodo le sei combinazioni in cui si attingono i valori minimi e massimi della reazione Fz, della reazione Mx e della reazione My.

Nodo	Cmb	Traslazione X	Traslazione Y	Traslazione Z	Rotazione X	Rotazione Y	Rotazione Z
		cm	cm	cm			
1	1	-1.92e-05	-7.89e-06	-0.23	-9.74e-06	-1.34e-05	0.0
1	2	-1.38e-05	-5.61e-06	-0.17	-6.95e-06	-7.67e-06	0.0
1	8	-6.42e-03	3.58e-03	-0.16	-4.44e-05	-4.76e-05	0.0
1	22	-3.19e-04	-8.09e-03	-0.17	1.21e-04	-1.89e-05	0.0
1	28	3.02e-03	-8.09e-03	-0.17	1.20e-04	6.63e-06	0.0
1	40	-2.68e-03	1.49e-03	-0.16	-2.26e-05	-2.28e-05	0.0
1	54	-1.41e-04	-3.38e-03	-0.17	4.63e-05	-1.09e-05	0.0
1	60	1.25e-03	-3.38e-03	-0.16	4.60e-05	0.0	0.0
2	1	1.44e-05	-7.78e-06	-0.21	-1.38e-05	-8.69e-05	0.0
2	2	1.03e-05	-5.49e-06	-0.16	-9.75e-06	-6.11e-05	0.0
2	12	6.41e-03	8.69e-05	-0.16	2.87e-05	-1.75e-05	0.0
2	19	-3.01e-03	-8.02e-03	-0.16	1.19e-04	-7.64e-05	0.0
2	29	3.29e-04	-8.02e-03	-0.16	1.20e-04	-4.88e-05	0.0
2	44	2.68e-03	3.16e-05	-0.15	6.26e-06	-4.47e-05	0.0
2	51	-1.25e-03	-3.35e-03	-0.15	4.40e-05	-6.92e-05	0.0
2	61	1.43e-04	-3.35e-03	-0.16	4.42e-05	-5.77e-05	0.0
3	1	1.44e-05	7.78e-06	-0.21	1.38e-05	-8.69e-05	0.0
3	2	1.03e-05	5.49e-06	-0.16	9.75e-06	-6.11e-05	0.0
3	18	6.41e-03	-8.69e-05	-0.16	-2.87e-05	-1.75e-05	0.0
3	25	-3.01e-03	8.02e-03	-0.16	-1.19e-04	-7.64e-05	0.0
3	31	3.29e-04	8.02e-03	-0.16	-1.20e-04	-4.88e-05	0.0
3	50	2.68e-03	-3.16e-05	-0.15	-6.26e-06	-4.47e-05	0.0
3	57	-1.25e-03	3.35e-03	-0.15	-4.40e-05	-6.92e-05	0.0
3	63	1.43e-04	3.35e-03	-0.16	-4.42e-05	-5.77e-05	0.0
4	1	-1.92e-05	7.89e-06	-0.23	9.74e-06	-1.34e-05	0.0
4	2	-1.38e-05	5.61e-06	-0.17	6.95e-06	-7.67e-06	0.0
4	6	-6.42e-03	-3.58e-03	-0.16	4.44e-05	-4.76e-05	0.0
4	24	-3.19e-04	8.09e-03	-0.17	-1.21e-04	-1.89e-05	0.0
4	34	3.02e-03	8.09e-03	-0.17	-1.20e-04	6.63e-06	0.0
4	38	-2.68e-03	-1.49e-03	-0.16	2.26e-05	-2.28e-05	0.0

4	56	-1.41e-04	3.38e-03	-0.17	-4.63e-05	-1.09e-05	0.0
4	66	1.25e-03	3.38e-03	-0.16	-4.60e-05	0.0	0.0
5	1	-1.87e-05	-8.67e-06	-0.23	-9.12e-06	-1.66e-05	0.0
5	2	-1.35e-05	-6.15e-06	-0.17	-6.49e-06	-9.91e-06	0.0
5	8	-6.42e-03	3.34e-03	-0.16	-4.39e-05	-4.86e-05	0.0
5	22	-3.19e-04	-7.76e-03	-0.17	1.20e-04	-2.02e-05	0.0
5	40	-2.68e-03	1.39e-03	-0.16	-2.21e-05	-2.45e-05	0.0
5	54	-1.41e-04	-3.25e-03	-0.17	4.63e-05	-1.27e-05	0.0
6	1	-1.87e-05	8.67e-06	-0.23	9.12e-06	-1.66e-05	0.0
6	2	-1.35e-05	6.15e-06	-0.17	6.49e-06	-9.91e-06	0.0
6	6	-6.42e-03	-3.34e-03	-0.16	4.39e-05	-4.86e-05	0.0
6	24	-3.19e-04	7.76e-03	-0.17	-1.20e-04	-2.02e-05	0.0
6	38	-2.68e-03	-1.39e-03	-0.16	2.21e-05	-2.45e-05	0.0
6	56	-1.41e-04	3.25e-03	-0.17	-4.63e-05	-1.27e-05	0.0
7	1	1.40e-05	-7.19e-06	-0.21	-1.29e-05	-8.46e-05	0.0
7	2	1.01e-05	-5.03e-06	-0.16	-9.07e-06	-5.95e-05	0.0
7	12	6.41e-03	-1.24e-04	-0.16	2.77e-05	-1.72e-05	0.0
7	29	3.29e-04	-7.70e-03	-0.16	1.19e-04	-4.79e-05	0.0
7	44	2.68e-03	-5.61e-05	-0.16	6.28e-06	-4.37e-05	0.0
7	61	1.43e-04	-3.22e-03	-0.16	4.44e-05	-5.65e-05	0.0
8	1	1.40e-05	7.19e-06	-0.21	1.29e-05	-8.46e-05	0.0
8	2	1.01e-05	5.03e-06	-0.16	9.07e-06	-5.95e-05	0.0
8	18	6.41e-03	1.24e-04	-0.16	-2.77e-05	-1.72e-05	0.0
8	31	3.29e-04	7.70e-03	-0.16	-1.19e-04	-4.79e-05	0.0
8	50	2.68e-03	5.61e-05	-0.16	-6.28e-06	-4.37e-05	0.0
8	63	1.43e-04	3.22e-03	-0.16	-4.44e-05	-5.65e-05	0.0
9	1	-2.04e-05	-7.38e-06	-0.23	-6.53e-06	-1.40e-05	0.0
9	2	-1.47e-05	-5.25e-06	-0.17	-4.67e-06	-8.11e-06	0.0
9	8	-6.20e-03	3.58e-03	-0.17	-4.22e-05	-4.80e-05	0.0
9	22	-6.60e-04	-8.09e-03	-0.17	1.21e-04	-1.79e-05	0.0
9	28	2.67e-03	-8.09e-03	-0.17	1.21e-04	7.39e-06	0.0
9	40	-2.59e-03	1.49e-03	-0.16	-2.05e-05	-2.33e-05	0.0
9	54	-2.84e-04	-3.38e-03	-0.17	4.79e-05	-1.07e-05	0.0
9	60	1.10e-03	-3.38e-03	-0.16	4.77e-05	0.0	0.0
10	1	1.64e-05	-7.28e-06	-0.21	-1.12e-05	-8.63e-05	0.0
10	2	1.18e-05	-5.14e-06	-0.16	-7.95e-06	-6.06e-05	0.0
10	12	6.20e-03	8.71e-05	-0.16	2.99e-05	-1.78e-05	0.0
10	19	-2.67e-03	-8.02e-03	-0.16	1.19e-04	-7.70e-05	0.0
10	29	6.67e-04	-8.02e-03	-0.16	1.20e-04	-4.97e-05	0.0
10	44	2.59e-03	3.19e-05	-0.15	7.64e-06	-4.45e-05	0.0
10	51	-1.10e-03	-3.35e-03	-0.15	4.50e-05	-6.91e-05	0.0
10	61	2.85e-04	-3.35e-03	-0.16	4.52e-05	-5.77e-05	0.0
11	1	-2.04e-05	7.38e-06	-0.23	6.53e-06	-1.40e-05	0.0
11	2	-1.47e-05	5.25e-06	-0.17	4.67e-06	-8.11e-06	0.0
11	6	-6.20e-03	-3.58e-03	-0.17	4.22e-05	-4.80e-05	0.0
11	24	-6.60e-04	8.09e-03	-0.17	-1.21e-04	-1.79e-05	0.0
11	34	2.67e-03	8.09e-03	-0.17	-1.21e-04	7.39e-06	0.0
11	38	-2.59e-03	-1.49e-03	-0.16	2.05e-05	-2.33e-05	0.0
11	56	-2.84e-04	3.38e-03	-0.17	-4.79e-05	-1.07e-05	0.0
11	66	1.10e-03	3.38e-03	-0.16	-4.77e-05	0.0	0.0
12	1	1.64e-05	7.28e-06	-0.21	1.12e-05	-8.63e-05	0.0
12	2	1.18e-05	5.14e-06	-0.16	7.95e-06	-6.06e-05	0.0
12	18	6.20e-03	-8.71e-05	-0.16	-2.99e-05	-1.78e-05	0.0
12	25	-2.67e-03	8.02e-03	-0.16	-1.19e-04	-7.70e-05	0.0
12	31	6.67e-04	8.02e-03	-0.16	-1.20e-04	-4.97e-05	0.0
12	50	2.59e-03	-3.19e-05	-0.15	-7.64e-06	-4.45e-05	0.0

12	57	-1.10e-03	3.35e-03	-0.15	-4.50e-05	-6.91e-05	0.0
12	63	2.85e-04	3.35e-03	-0.16	-4.52e-05	-5.77e-05	0.0
13	1	-2.22e-05	1.04e-05	-0.23	4.34e-06	-1.89e-05	0.0
13	2	-1.60e-05	7.39e-06	-0.17	3.09e-06	-1.16e-05	0.0
13	6	-6.20e-03	-3.34e-03	-0.16	4.02e-05	-4.91e-05	1.28e-05
13	24	-6.61e-04	7.77e-03	-0.17	-1.21e-04	-2.16e-05	-1.76e-05
13	34	2.67e-03	7.77e-03	-0.17	-1.21e-04	2.58e-06	-1.77e-05
13	38	-2.59e-03	-1.39e-03	-0.16	1.87e-05	-2.57e-05	5.40e-06
13	56	-2.85e-04	3.25e-03	-0.17	-4.87e-05	-1.42e-05	-7.26e-06
13	66	1.10e-03	3.25e-03	-0.16	-4.86e-05	-4.20e-06	-7.28e-06
14	1	-2.22e-05	-1.04e-05	-0.23	-4.34e-06	-1.89e-05	0.0
14	2	-1.60e-05	-7.39e-06	-0.17	-3.09e-06	-1.16e-05	0.0
14	8	-6.20e-03	3.34e-03	-0.16	-4.02e-05	-4.91e-05	-1.28e-05
14	22	-6.61e-04	-7.77e-03	-0.17	1.21e-04	-2.16e-05	1.76e-05
14	28	2.67e-03	-7.77e-03	-0.17	1.21e-04	2.58e-06	1.77e-05
14	40	-2.59e-03	1.39e-03	-0.16	-1.87e-05	-2.57e-05	-5.40e-06
14	54	-2.85e-04	-3.25e-03	-0.17	4.87e-05	-1.42e-05	7.26e-06
14	60	1.10e-03	-3.25e-03	-0.16	4.86e-05	-4.20e-06	7.28e-06
15	1	1.61e-05	7.38e-06	-0.21	1.04e-05	-8.34e-05	0.0
15	2	1.16e-05	5.16e-06	-0.16	7.30e-06	-5.86e-05	0.0
15	18	6.20e-03	1.24e-04	-0.16	-3.04e-05	-1.68e-05	0.0
15	31	6.66e-04	7.70e-03	-0.16	-1.20e-04	-4.71e-05	0.0
15	50	2.59e-03	5.62e-05	-0.16	-8.28e-06	-4.29e-05	0.0
15	63	2.84e-04	3.22e-03	-0.16	-4.56e-05	-5.55e-05	0.0
16	1	1.61e-05	-7.38e-06	-0.21	-1.04e-05	-8.34e-05	0.0
16	2	1.16e-05	-5.16e-06	-0.16	-7.30e-06	-5.86e-05	0.0
16	12	6.20e-03	-1.24e-04	-0.16	3.04e-05	-1.68e-05	0.0
16	29	6.66e-04	-7.70e-03	-0.16	1.20e-04	-4.71e-05	0.0
16	44	2.59e-03	-5.62e-05	-0.16	8.28e-06	-4.29e-05	0.0
16	61	2.84e-04	-3.22e-03	-0.16	4.56e-05	-5.55e-05	0.0
17	1	7.98e-06	1.20e-05	-0.22	4.35e-06	-3.18e-05	0.0
17	2	5.71e-06	8.48e-06	-0.16	3.07e-06	-2.09e-05	0.0
17	18	6.19e-03	1.93e-03	-0.16	-3.36e-05	1.97e-05	-1.25e-05
17	24	-6.38e-04	5.90e-03	-0.17	-1.20e-04	-3.10e-05	-1.76e-05
17	50	2.58e-03	8.09e-04	-0.16	-1.22e-05	-2.94e-06	-5.19e-06
17	56	-2.61e-04	2.47e-03	-0.16	-4.82e-05	-2.41e-05	-7.33e-06
18	1	7.98e-06	-1.20e-05	-0.22	-4.35e-06	-3.18e-05	0.0
18	2	5.71e-06	-8.48e-06	-0.16	-3.07e-06	-2.09e-05	0.0
18	12	6.19e-03	-1.93e-03	-0.16	3.36e-05	1.97e-05	1.25e-05
18	22	-6.38e-04	-5.90e-03	-0.17	1.20e-04	-3.10e-05	1.76e-05
18	44	2.58e-03	-8.09e-04	-0.16	1.22e-05	-2.94e-06	5.19e-06
18	54	-2.61e-04	-2.47e-03	-0.16	4.82e-05	-2.41e-05	7.33e-06
19	1	5.38e-06	7.73e-06	-0.22	8.07e-06	-6.87e-05	0.0
19	2	3.90e-06	5.35e-06	-0.16	5.62e-06	-4.79e-05	0.0
19	18	6.19e-03	1.00e-03	-0.16	-3.09e-05	-1.00e-05	0.0
19	31	6.58e-04	6.46e-03	-0.17	-1.17e-04	-3.66e-05	0.0
19	50	2.58e-03	4.22e-04	-0.16	-9.67e-06	-3.32e-05	0.0
19	63	2.76e-04	2.70e-03	-0.16	-4.58e-05	-4.43e-05	0.0
20	1	5.38e-06	-7.73e-06	-0.22	-8.07e-06	-6.87e-05	0.0
20	2	3.90e-06	-5.35e-06	-0.16	-5.62e-06	-4.79e-05	0.0
20	12	6.19e-03	-1.00e-03	-0.16	3.09e-05	-1.00e-05	0.0
20	29	6.58e-04	-6.46e-03	-0.17	1.17e-04	-3.66e-05	0.0
20	44	2.58e-03	-4.22e-04	-0.16	9.67e-06	-3.32e-05	0.0
20	61	2.76e-04	-2.70e-03	-0.16	4.58e-05	-4.43e-05	0.0
21	1	6.75e-06	6.69e-06	-0.22	8.84e-06	-6.96e-05	0.0
21	2	4.88e-06	4.63e-06	-0.16	6.14e-06	-4.85e-05	0.0

21	18	6.41e-03	1.00e-03	-0.16	-3.02e-05	-1.08e-05	0.0
21	31	3.25e-04	6.46e-03	-0.17	-1.17e-04	-3.67e-05	0.0
21	50	2.67e-03	4.22e-04	-0.16	-9.14e-06	-3.39e-05	0.0
21	63	1.38e-04	2.70e-03	-0.16	-4.55e-05	-4.47e-05	0.0
22	1	6.75e-06	-6.69e-06	-0.22	-8.84e-06	-6.96e-05	0.0
22	2	4.88e-06	-4.63e-06	-0.16	-6.14e-06	-4.85e-05	0.0
22	12	6.41e-03	-1.00e-03	-0.16	3.02e-05	-1.08e-05	0.0
22	29	3.25e-04	-6.46e-03	-0.17	1.17e-04	-3.67e-05	0.0
22	44	2.67e-03	-4.22e-04	-0.16	9.14e-06	-3.39e-05	0.0
22	61	1.38e-04	-2.70e-03	-0.16	4.55e-05	-4.47e-05	0.0
23	1	1.49e-06	1.05e-05	-0.22	7.12e-06	-3.45e-05	0.0
23	2	1.04e-06	7.37e-06	-0.16	4.98e-06	-2.28e-05	0.0
23	18	6.40e-03	1.92e-03	-0.16	-3.17e-05	1.74e-05	0.0
23	24	-3.06e-04	5.90e-03	-0.17	-1.18e-04	-3.26e-05	0.0
23	50	2.67e-03	8.08e-04	-0.16	-1.04e-05	-5.14e-06	0.0
23	56	-1.26e-04	2.47e-03	-0.16	-4.63e-05	-2.59e-05	0.0
24	1	1.49e-06	-1.05e-05	-0.22	-7.12e-06	-3.45e-05	0.0
24	2	1.04e-06	-7.37e-06	-0.16	-4.98e-06	-2.28e-05	0.0
24	12	6.40e-03	-1.92e-03	-0.16	3.17e-05	1.74e-05	0.0
24	22	-3.06e-04	-5.90e-03	-0.17	1.18e-04	-3.26e-05	0.0
24	44	2.67e-03	-8.08e-04	-0.16	1.04e-05	-5.14e-06	0.0
24	54	-1.26e-04	-2.47e-03	-0.16	4.63e-05	-2.59e-05	0.0
25	1	1.05e-05	-5.72e-06	-0.22	-1.00e-05	-7.88e-05	0.0
25	2	7.54e-06	-3.92e-06	-0.16	-6.99e-06	-5.53e-05	0.0
25	12	6.41e-03	-5.56e-04	-0.16	2.92e-05	-1.69e-05	0.0
25	29	3.27e-04	-7.07e-03	-0.17	1.18e-04	-4.35e-05	0.0
25	44	2.67e-03	-2.35e-04	-0.16	8.20e-06	-4.09e-05	0.0
25	61	1.40e-04	-2.95e-03	-0.16	4.53e-05	-5.20e-05	0.0
26	1	1.05e-05	5.72e-06	-0.22	1.00e-05	-7.88e-05	0.0
26	2	7.54e-06	3.92e-06	-0.16	6.99e-06	-5.53e-05	0.0
26	18	6.41e-03	5.56e-04	-0.16	-2.92e-05	-1.69e-05	0.0
26	31	3.27e-04	7.07e-03	-0.17	-1.18e-04	-4.35e-05	0.0
26	50	2.67e-03	2.35e-04	-0.16	-8.20e-06	-4.09e-05	0.0
26	63	1.40e-04	2.95e-03	-0.16	-4.53e-05	-5.20e-05	0.0
27	1	-9.47e-06	-5.92e-06	-0.23	-5.17e-06	-2.31e-05	0.0
27	2	-6.86e-06	-4.09e-06	-0.17	-3.63e-06	-1.46e-05	0.0
27	8	-6.41e-03	2.62e-03	-0.16	-4.12e-05	-4.94e-05	0.0
27	22	-3.13e-04	-6.81e-03	-0.17	1.20e-04	-2.44e-05	0.0
27	40	-2.67e-03	1.09e-03	-0.16	-1.92e-05	-2.76e-05	0.0
27	54	-1.34e-04	-2.85e-03	-0.17	4.80e-05	-1.72e-05	0.0
28	1	-9.47e-06	5.92e-06	-0.23	5.17e-06	-2.31e-05	0.0
28	2	-6.86e-06	4.09e-06	-0.17	3.63e-06	-1.46e-05	0.0
28	6	-6.41e-03	-2.62e-03	-0.16	4.12e-05	-4.94e-05	0.0
28	24	-3.13e-04	6.81e-03	-0.17	-1.20e-04	-2.44e-05	0.0
28	38	-2.67e-03	-1.09e-03	-0.16	1.92e-05	-2.76e-05	0.0
28	56	-1.34e-04	2.85e-03	-0.17	-4.80e-05	-1.72e-05	0.0
29	1	-1.07e-05	4.70e-06	-0.23	4.38e-06	-2.35e-05	0.0
29	2	-7.78e-06	3.21e-06	-0.17	3.13e-06	-1.49e-05	0.0
29	6	-6.20e-03	-2.62e-03	-0.16	4.03e-05	-5.03e-05	1.26e-05
29	24	-6.52e-04	6.81e-03	-0.17	-1.20e-04	-2.39e-05	-1.75e-05
29	38	-2.58e-03	-1.09e-03	-0.16	1.87e-05	-2.82e-05	5.27e-06
29	56	-2.76e-04	2.85e-03	-0.16	-4.83e-05	-1.72e-05	-7.26e-06
30	1	-1.07e-05	-4.70e-06	-0.23	-4.38e-06	-2.35e-05	0.0
30	2	-7.78e-06	-3.21e-06	-0.17	-3.13e-06	-1.49e-05	0.0
30	8	-6.20e-03	2.62e-03	-0.16	-4.03e-05	-5.03e-05	-1.26e-05
30	22	-6.52e-04	-6.81e-03	-0.17	1.20e-04	-2.39e-05	1.75e-05

30	40	-2.58e-03	1.09e-03	-0.16	-1.87e-05	-2.82e-05	-5.27e-06
30	54	-2.76e-04	-2.85e-03	-0.16	4.83e-05	-1.72e-05	7.26e-06
31	1	1.10e-05	5.77e-06	-0.22	8.14e-06	-7.79e-05	0.0
31	2	7.94e-06	3.96e-06	-0.16	5.65e-06	-5.46e-05	0.0
31	18	6.19e-03	5.56e-04	-0.16	-3.03e-05	-1.64e-05	0.0
31	31	6.62e-04	7.07e-03	-0.16	-1.19e-04	-4.43e-05	0.0
31	50	2.58e-03	2.35e-04	-0.16	-9.39e-06	-4.03e-05	0.0
31	63	2.80e-04	2.95e-03	-0.16	-4.63e-05	-5.19e-05	0.0
32	1	1.10e-05	-5.77e-06	-0.22	-8.14e-06	-7.79e-05	0.0
32	2	7.94e-06	-3.96e-06	-0.16	-5.65e-06	-5.46e-05	0.0
32	12	6.19e-03	-5.56e-04	-0.16	3.03e-05	-1.64e-05	0.0
32	29	6.62e-04	-7.07e-03	-0.16	1.19e-04	-4.43e-05	0.0
32	44	2.58e-03	-2.35e-04	-0.16	9.39e-06	-4.03e-05	0.0
32	61	2.80e-04	-2.95e-03	-0.16	4.63e-05	-5.19e-05	0.0
33	1	-1.59e-05	0.0	-0.23	0.0	-1.67e-05	0.0
33	2	-1.14e-05	0.0	-0.17	0.0	-1.01e-05	0.0
33	3	-5.56e-03	9.49e-05	-0.17	3.66e-05	-4.77e-05	0.0
33	5	-5.56e-03	-2.46e-03	-0.17	3.63e-05	-4.77e-05	0.0
33	28	1.65e-03	-8.08e-03	-0.16	1.22e-04	4.43e-06	0.0
33	35	-2.32e-03	3.83e-05	-0.16	1.53e-05	-2.43e-05	0.0
33	37	-2.32e-03	-1.02e-03	-0.16	1.52e-05	-2.43e-05	0.0
33	60	6.80e-04	-3.37e-03	-0.16	5.10e-05	-2.60e-06	0.0
34	1	1.77e-05	0.0	-0.21	0.0	-8.35e-05	0.0
34	2	1.28e-05	0.0	-0.16	0.0	-5.86e-05	0.0
34	15	5.56e-03	3.55e-03	-0.16	-3.67e-05	-1.84e-05	0.0
34	17	5.56e-03	1.03e-03	-0.16	-3.69e-05	-1.84e-05	0.0
34	19	-1.65e-03	-8.01e-03	-0.15	1.23e-04	-7.42e-05	0.0
34	47	2.32e-03	1.48e-03	-0.15	-1.53e-05	-4.35e-05	0.0
34	49	2.32e-03	4.31e-04	-0.15	-1.54e-05	-4.35e-05	0.0
34	51	-6.78e-04	-3.35e-03	-0.15	5.12e-05	-6.67e-05	0.0
35	1	1.66e-05	0.0	-0.21	0.0	-8.15e-05	0.0
35	2	1.19e-05	0.0	-0.16	0.0	-5.72e-05	0.0
35	15	5.56e-03	3.31e-03	-0.16	-3.69e-05	-1.80e-05	1.25e-05
35	17	5.56e-03	1.10e-03	-0.16	-3.67e-05	-1.80e-05	-3.42e-06
35	19	-1.65e-03	-7.69e-03	-0.15	1.23e-04	-7.24e-05	-1.74e-05
35	47	2.32e-03	1.38e-03	-0.15	-1.54e-05	-4.24e-05	5.18e-06
35	49	2.32e-03	4.63e-04	-0.15	-1.53e-05	-4.24e-05	-1.42e-06
35	51	-6.79e-04	-3.21e-03	-0.15	5.13e-05	-6.51e-05	-7.27e-06
36	1	-1.64e-05	0.0	-0.23	0.0	-1.89e-05	0.0
36	2	-1.18e-05	0.0	-0.17	0.0	-1.16e-05	0.0
36	3	-5.56e-03	-1.12e-04	-0.17	3.63e-05	-4.86e-05	-1.25e-05
36	5	-5.56e-03	-2.35e-03	-0.17	3.68e-05	-4.86e-05	3.42e-06
36	28	1.65e-03	-7.76e-03	-0.16	1.23e-04	2.75e-06	1.77e-05
36	35	-2.32e-03	-4.82e-05	-0.16	1.52e-05	-2.55e-05	-5.18e-06
36	37	-2.32e-03	-9.79e-04	-0.16	1.54e-05	-2.55e-05	1.42e-06
36	60	6.80e-04	-3.24e-03	-0.16	5.12e-05	-4.16e-06	7.35e-06
37	1	9.97e-06	0.0	-0.22	0.0	-7.73e-05	0.0
37	2	7.20e-06	0.0	-0.16	0.0	-5.42e-05	0.0
37	15	5.56e-03	2.84e-03	-0.16	-3.70e-05	-1.56e-05	0.0
37	17	5.56e-03	1.26e-03	-0.16	-3.68e-05	-1.56e-05	0.0
37	19	-1.66e-03	-7.06e-03	-0.15	1.23e-04	-6.92e-05	0.0
37	47	2.32e-03	1.18e-03	-0.16	-1.55e-05	-3.97e-05	0.0
37	49	2.32e-03	5.29e-04	-0.16	-1.54e-05	-3.97e-05	0.0
37	51	-6.85e-04	-2.95e-03	-0.15	5.14e-05	-6.20e-05	0.0
38	1	2.84e-06	0.0	-0.22	0.0	-6.97e-05	0.0
38	2	2.05e-06	0.0	-0.16	0.0	-4.86e-05	0.0

38	15	5.56e-03	2.36e-03	-0.16	-3.71e-05	-9.91e-06	1.26e-05
38	17	5.56e-03	1.42e-03	-0.16	-3.68e-05	-9.91e-06	-3.41e-06
38	19	-1.66e-03	-6.45e-03	-0.16	1.23e-04	-6.28e-05	-1.77e-05
38	47	2.31e-03	9.86e-04	-0.16	-1.55e-05	-3.37e-05	5.23e-06
38	49	2.31e-03	5.96e-04	-0.16	-1.54e-05	-3.37e-05	-1.41e-06
38	51	-6.91e-04	-2.69e-03	-0.16	5.14e-05	-5.57e-05	-7.35e-06
39	1	3.80e-06	0.0	-0.22	0.0	-3.24e-05	0.0
39	2	2.72e-06	0.0	-0.16	0.0	-2.14e-05	0.0
39	10	-5.55e-03	1.59e-03	-0.16	-3.66e-05	-5.79e-05	3.38e-06
39	15	5.55e-03	1.43e-03	-0.16	-3.64e-05	1.83e-05	1.25e-05
39	28	1.67e-03	-5.89e-03	-0.16	1.23e-04	-8.35e-06	1.77e-05
39	42	-2.31e-03	6.62e-04	-0.16	-1.53e-05	-3.57e-05	1.40e-06
39	47	2.31e-03	5.99e-04	-0.16	-1.52e-05	-3.92e-06	5.21e-06
39	60	6.96e-04	-2.46e-03	-0.16	5.13e-05	-1.50e-05	7.36e-06
40	1	-6.72e-06	0.0	-0.23	0.0	-2.31e-05	0.0
40	2	-4.85e-06	0.0	-0.17	0.0	-1.45e-05	0.0
40	3	-5.55e-03	-7.59e-04	-0.16	3.63e-05	-5.06e-05	0.0
40	9	-5.55e-03	7.59e-04	-0.16	-3.63e-05	-5.06e-05	0.0
40	28	1.66e-03	-6.81e-03	-0.16	1.23e-04	0.0	0.0
40	35	-2.31e-03	-3.18e-04	-0.16	1.52e-05	-2.81e-05	0.0
40	41	-2.31e-03	3.18e-04	-0.16	-1.52e-05	-2.81e-05	0.0
40	60	6.87e-04	-2.84e-03	-0.16	5.13e-05	-7.21e-06	0.0
41	1	-1.95e-05	-8.25e-06	-0.23	-9.59e-06	-1.48e-05	0.0
41	2	-1.41e-05	-5.86e-06	-0.17	-6.84e-06	-8.62e-06	0.0
41	8	-6.42e-03	3.46e-03	-0.16	-4.47e-05	-4.76e-05	0.0
41	22	-3.19e-04	-7.93e-03	-0.17	1.22e-04	-1.93e-05	0.0
41	28	3.02e-03	-7.93e-03	-0.17	1.21e-04	5.70e-06	0.0
41	40	-2.68e-03	1.44e-03	-0.16	-2.27e-05	-2.33e-05	0.0
41	54	-1.41e-04	-3.31e-03	-0.17	4.68e-05	-1.16e-05	0.0
41	60	1.25e-03	-3.31e-03	-0.16	4.66e-05	-1.15e-06	0.0
42	1	-1.95e-05	8.25e-06	-0.23	9.59e-06	-1.48e-05	0.0
42	2	-1.41e-05	5.86e-06	-0.17	6.84e-06	-8.62e-06	0.0
42	6	-6.42e-03	-3.46e-03	-0.16	4.47e-05	-4.76e-05	0.0
42	24	-3.19e-04	7.93e-03	-0.17	-1.22e-04	-1.93e-05	0.0
42	34	3.02e-03	7.93e-03	-0.17	-1.21e-04	5.70e-06	0.0
42	38	-2.68e-03	-1.44e-03	-0.16	2.27e-05	-2.33e-05	0.0
42	56	-1.41e-04	3.31e-03	-0.17	-4.68e-05	-1.16e-05	0.0
42	66	1.25e-03	3.31e-03	-0.16	-4.66e-05	-1.15e-06	0.0
43	1	1.45e-05	-7.36e-06	-0.21	-1.35e-05	-8.59e-05	0.0
43	2	1.04e-05	-5.17e-06	-0.16	-9.51e-06	-6.04e-05	0.0
43	12	6.42e-03	-1.79e-05	-0.16	2.93e-05	-1.78e-05	0.0
43	29	3.29e-04	-7.86e-03	-0.16	1.21e-04	-4.85e-05	0.0
43	44	2.68e-03	-1.19e-05	-0.16	6.65e-06	-4.44e-05	0.0
43	61	1.43e-04	-3.28e-03	-0.16	4.49e-05	-5.72e-05	0.0
44	1	1.45e-05	7.36e-06	-0.21	1.35e-05	-8.59e-05	0.0
44	2	1.04e-05	5.17e-06	-0.16	9.51e-06	-6.04e-05	0.0
44	18	6.42e-03	1.79e-05	-0.16	-2.93e-05	-1.78e-05	0.0
44	31	3.29e-04	7.86e-03	-0.16	-1.21e-04	-4.85e-05	0.0
44	50	2.68e-03	1.19e-05	-0.16	-6.65e-06	-4.44e-05	0.0
44	63	1.43e-04	3.28e-03	-0.16	-4.49e-05	-5.72e-05	0.0
45	1	-1.97e-05	-8.19e-06	-0.23	-8.41e-06	-1.36e-05	0.0
45	2	-1.42e-05	-5.82e-06	-0.17	-6.00e-06	-7.83e-06	0.0
45	8	-6.31e-03	3.58e-03	-0.17	-4.34e-05	-4.88e-05	0.0
45	22	-4.89e-04	-8.09e-03	-0.17	1.20e-04	-1.86e-05	0.0
45	28	2.85e-03	-8.09e-03	-0.17	1.20e-04	7.40e-06	0.0
45	40	-2.64e-03	1.49e-03	-0.16	-2.17e-05	-2.35e-05	0.0

45	54	-2.12e-04	-3.38e-03	-0.17	4.67e-05	-1.09e-05	0.0
45	60	1.18e-03	-3.38e-03	-0.16	4.65e-05	0.0	0.0
46	1	1.53e-05	-7.95e-06	-0.21	-1.27e-05	-8.66e-05	0.0
46	2	1.10e-05	-5.61e-06	-0.16	-9.03e-06	-6.09e-05	0.0
46	12	6.31e-03	8.67e-05	-0.16	2.90e-05	-1.66e-05	0.0
46	19	-2.84e-03	-8.02e-03	-0.16	1.19e-04	-7.71e-05	0.0
46	29	4.98e-04	-8.02e-03	-0.16	1.19e-04	-4.90e-05	0.0
46	44	2.63e-03	3.14e-05	-0.15	6.73e-06	-4.41e-05	0.0
46	51	-1.18e-03	-3.35e-03	-0.15	4.42e-05	-6.93e-05	0.0
46	61	2.14e-04	-3.35e-03	-0.16	4.44e-05	-5.76e-05	0.0
47	1	-1.97e-05	8.19e-06	-0.23	8.41e-06	-1.36e-05	0.0
47	2	-1.42e-05	5.82e-06	-0.17	6.00e-06	-7.83e-06	0.0
47	6	-6.31e-03	-3.58e-03	-0.17	4.34e-05	-4.88e-05	0.0
47	24	-4.89e-04	8.09e-03	-0.17	-1.20e-04	-1.86e-05	0.0
47	34	2.85e-03	8.09e-03	-0.17	-1.20e-04	7.40e-06	0.0
47	38	-2.64e-03	-1.49e-03	-0.16	2.17e-05	-2.35e-05	0.0
47	56	-2.12e-04	3.38e-03	-0.17	-4.67e-05	-1.09e-05	0.0
47	66	1.18e-03	3.38e-03	-0.16	-4.65e-05	0.0	0.0
48	1	1.53e-05	7.95e-06	-0.21	1.27e-05	-8.66e-05	0.0
48	2	1.10e-05	5.61e-06	-0.16	9.03e-06	-6.09e-05	0.0
48	18	6.31e-03	-8.67e-05	-0.16	-2.90e-05	-1.66e-05	0.0
48	25	-2.84e-03	8.02e-03	-0.16	-1.19e-04	-7.71e-05	0.0
48	31	4.98e-04	8.02e-03	-0.16	-1.19e-04	-4.90e-05	0.0
48	50	2.63e-03	-3.14e-05	-0.15	-6.73e-06	-4.41e-05	0.0
48	57	-1.18e-03	3.35e-03	-0.15	-4.42e-05	-6.93e-05	0.0
48	63	2.14e-04	3.35e-03	-0.16	-4.44e-05	-5.76e-05	0.0
49	1	1.46e-05	6.87e-06	-0.21	1.19e-05	-8.39e-05	0.0
49	2	1.05e-05	4.80e-06	-0.16	8.39e-06	-5.89e-05	0.0
49	18	6.31e-03	1.24e-04	-0.16	-2.96e-05	-1.61e-05	0.0
49	31	4.97e-04	7.70e-03	-0.16	-1.19e-04	-4.73e-05	0.0
49	50	2.63e-03	5.58e-05	-0.16	-7.39e-06	-4.29e-05	0.0
49	63	2.13e-04	3.22e-03	-0.16	-4.48e-05	-5.59e-05	0.0
50	1	-1.94e-05	8.15e-06	-0.23	7.72e-06	-1.75e-05	0.0
50	2	-1.40e-05	5.79e-06	-0.17	5.50e-06	-1.06e-05	0.0
50	6	-6.31e-03	-3.34e-03	-0.16	4.29e-05	-4.96e-05	0.0
50	24	-4.89e-04	7.76e-03	-0.17	-1.20e-04	-2.09e-05	0.0
50	38	-2.64e-03	-1.39e-03	-0.16	2.12e-05	-2.53e-05	0.0
50	56	-2.12e-04	3.25e-03	-0.17	-4.68e-05	-1.33e-05	0.0
51	1	1.06e-05	5.75e-06	-0.22	9.40e-06	-7.83e-05	0.0
51	2	7.67e-06	3.94e-06	-0.16	6.54e-06	-5.50e-05	0.0
51	18	6.30e-03	5.56e-04	-0.16	-2.95e-05	-1.69e-05	0.0
51	31	4.94e-04	7.07e-03	-0.16	-1.18e-04	-4.40e-05	0.0
51	50	2.63e-03	2.35e-04	-0.16	-8.58e-06	-4.07e-05	0.0
51	63	2.10e-04	2.95e-03	-0.16	-4.56e-05	-5.20e-05	0.0
52	1	5.95e-06	7.00e-06	-0.22	8.83e-06	-6.92e-05	0.0
52	2	4.31e-06	4.85e-06	-0.16	6.14e-06	-4.82e-05	0.0
52	18	6.30e-03	1.00e-03	-0.16	-3.03e-05	-1.04e-05	0.0
52	31	4.91e-04	6.46e-03	-0.17	-1.17e-04	-3.67e-05	0.0
52	50	2.63e-03	4.22e-04	-0.16	-9.14e-06	-3.36e-05	0.0
52	63	2.07e-04	2.70e-03	-0.16	-4.54e-05	-4.45e-05	0.0
53	1	3.46e-06	1.12e-05	-0.22	6.70e-06	-3.37e-05	0.0
53	2	2.45e-06	7.86e-06	-0.16	4.70e-06	-2.22e-05	0.0
53	18	6.30e-03	1.93e-03	-0.16	-3.20e-05	1.81e-05	0.0
53	24	-4.73e-04	5.90e-03	-0.17	-1.18e-04	-3.25e-05	0.0
53	50	2.62e-03	8.08e-04	-0.16	-1.06e-05	-4.50e-06	0.0
53	56	-1.95e-04	2.47e-03	-0.16	-4.65e-05	-2.56e-05	0.0

54	1	-9.85e-06	5.45e-06	-0.23	4.85e-06	-2.34e-05	0.0
54	2	-7.16e-06	3.76e-06	-0.17	3.42e-06	-1.48e-05	0.0
54	6	-6.30e-03	-2.62e-03	-0.16	4.09e-05	-4.97e-05	0.0
54	24	-4.83e-04	6.81e-03	-0.17	-1.20e-04	-2.41e-05	0.0
54	38	-2.63e-03	-1.09e-03	-0.16	1.90e-05	-2.79e-05	0.0
54	56	-2.05e-04	2.85e-03	-0.16	-4.81e-05	-1.72e-05	0.0
55	1	1.51e-05	7.41e-06	-0.21	1.22e-05	-8.49e-05	0.0
55	2	1.09e-05	5.20e-06	-0.16	8.61e-06	-5.96e-05	0.0
55	18	6.31e-03	1.79e-05	-0.16	-3.22e-05	-8.70e-06	-1.26e-05
55	31	4.97e-04	7.86e-03	-0.16	-1.29e-04	-4.62e-05	1.76e-05
55	50	2.63e-03	1.19e-05	-0.16	-8.30e-06	-4.01e-05	-5.20e-06
55	63	2.13e-04	3.28e-03	-0.16	-4.89e-05	-5.57e-05	7.37e-06
56	1	1.74e-05	0.0	-0.21	0.0	-8.26e-05	0.0
56	2	1.25e-05	0.0	-0.16	0.0	-5.80e-05	0.0
56	15	5.56e-03	3.43e-03	-0.16	-3.69e-05	-1.83e-05	0.0
56	17	5.56e-03	1.06e-03	-0.16	-3.67e-05	-1.83e-05	0.0
56	19	-1.65e-03	-7.85e-03	-0.15	1.23e-04	-7.34e-05	0.0
56	47	2.32e-03	1.43e-03	-0.15	-1.54e-05	-4.30e-05	0.0
56	49	2.32e-03	4.47e-04	-0.15	-1.53e-05	-4.30e-05	0.0
56	51	-6.79e-04	-3.28e-03	-0.15	5.13e-05	-6.60e-05	0.0
57	1	1.57e-05	7.54e-06	-0.21	1.08e-05	-8.51e-05	0.0
57	2	1.13e-05	5.30e-06	-0.16	7.61e-06	-5.98e-05	0.0
57	18	6.20e-03	1.79e-05	-0.16	-3.05e-05	-1.79e-05	0.0
57	31	6.66e-04	7.86e-03	-0.16	-1.21e-04	-4.87e-05	0.0
57	50	2.59e-03	1.20e-05	-0.16	-8.09e-06	-4.40e-05	0.0
57	63	2.84e-04	3.28e-03	-0.16	-4.60e-05	-5.69e-05	0.0
58	1	1.57e-05	-7.54e-06	-0.21	-1.08e-05	-8.51e-05	0.0
58	2	1.13e-05	-5.30e-06	-0.16	-7.61e-06	-5.98e-05	0.0
58	12	6.20e-03	-1.79e-05	-0.16	3.05e-05	-1.79e-05	0.0
58	29	6.66e-04	-7.86e-03	-0.16	1.21e-04	-4.87e-05	0.0
58	44	2.59e-03	-1.20e-05	-0.16	8.09e-06	-4.40e-05	0.0
58	61	2.84e-04	-3.28e-03	-0.16	4.60e-05	-5.69e-05	0.0
59	1	1.51e-05	-7.41e-06	-0.21	-1.22e-05	-8.49e-05	0.0
59	2	1.09e-05	-5.20e-06	-0.16	-8.61e-06	-5.96e-05	0.0
59	12	6.31e-03	-1.79e-05	-0.16	3.22e-05	-8.70e-06	1.26e-05
59	29	4.97e-04	-7.86e-03	-0.16	1.29e-04	-4.62e-05	-1.76e-05
59	44	2.63e-03	-1.19e-05	-0.16	8.30e-06	-4.01e-05	5.20e-06
59	61	2.13e-04	-3.28e-03	-0.16	4.89e-05	-5.57e-05	-7.37e-06
60	1	-1.94e-05	-8.15e-06	-0.23	-7.72e-06	-1.75e-05	0.0
60	2	-1.40e-05	-5.79e-06	-0.17	-5.50e-06	-1.06e-05	0.0
60	8	-6.31e-03	3.34e-03	-0.16	-4.29e-05	-4.96e-05	0.0
60	22	-4.89e-04	-7.76e-03	-0.17	1.20e-04	-2.09e-05	0.0
60	40	-2.64e-03	1.39e-03	-0.16	-2.12e-05	-2.53e-05	0.0
60	54	-2.12e-04	-3.25e-03	-0.17	4.68e-05	-1.33e-05	0.0
61	1	1.46e-05	-6.87e-06	-0.21	-1.19e-05	-8.39e-05	0.0
61	2	1.05e-05	-4.80e-06	-0.16	-8.39e-06	-5.89e-05	0.0
61	12	6.31e-03	-1.24e-04	-0.16	2.96e-05	-1.61e-05	0.0
61	29	4.97e-04	-7.70e-03	-0.16	1.19e-04	-4.73e-05	0.0
61	44	2.63e-03	-5.58e-05	-0.16	7.39e-06	-4.29e-05	0.0
61	61	2.13e-04	-3.22e-03	-0.16	4.48e-05	-5.59e-05	0.0
62	1	1.06e-05	-5.75e-06	-0.22	-9.40e-06	-7.83e-05	0.0
62	2	7.67e-06	-3.94e-06	-0.16	-6.54e-06	-5.50e-05	0.0
62	12	6.30e-03	-5.56e-04	-0.16	2.95e-05	-1.69e-05	0.0
62	29	4.94e-04	-7.07e-03	-0.16	1.18e-04	-4.40e-05	0.0
62	44	2.63e-03	-2.35e-04	-0.16	8.58e-06	-4.07e-05	0.0
62	61	2.10e-04	-2.95e-03	-0.16	4.56e-05	-5.20e-05	0.0

63	1	5.95e-06	-7.00e-06	-0.22	-8.83e-06	-6.92e-05	0.0
63	2	4.31e-06	-4.85e-06	-0.16	-6.14e-06	-4.82e-05	0.0
63	12	6.30e-03	-1.00e-03	-0.16	3.03e-05	-1.04e-05	0.0
63	29	4.91e-04	-6.46e-03	-0.17	1.17e-04	-3.67e-05	0.0
63	44	2.63e-03	-4.22e-04	-0.16	9.14e-06	-3.36e-05	0.0
63	61	2.07e-04	-2.70e-03	-0.16	4.54e-05	-4.45e-05	0.0
64	1	3.46e-06	-1.12e-05	-0.22	-6.70e-06	-3.37e-05	0.0
64	2	2.45e-06	-7.86e-06	-0.16	-4.70e-06	-2.22e-05	0.0
64	12	6.30e-03	-1.93e-03	-0.16	3.20e-05	1.81e-05	0.0
64	22	-4.73e-04	-5.90e-03	-0.17	1.18e-04	-3.25e-05	0.0
64	44	2.62e-03	-8.08e-04	-0.16	1.06e-05	-4.50e-06	0.0
64	54	-1.95e-04	-2.47e-03	-0.16	4.65e-05	-2.56e-05	0.0
65	1	-9.85e-06	-5.45e-06	-0.23	-4.85e-06	-2.34e-05	0.0
65	2	-7.16e-06	-3.76e-06	-0.17	-3.42e-06	-1.48e-05	0.0
65	8	-6.30e-03	2.62e-03	-0.16	-4.09e-05	-4.97e-05	0.0
65	22	-4.83e-04	-6.81e-03	-0.17	1.20e-04	-2.41e-05	0.0
65	40	-2.63e-03	1.09e-03	-0.16	-1.90e-05	-2.79e-05	0.0
65	54	-2.05e-04	-2.85e-03	-0.16	4.81e-05	-1.72e-05	0.0
66	1	-1.97e-05	8.14e-06	-0.23	7.97e-06	-1.57e-05	0.0
66	2	-1.41e-05	5.78e-06	-0.17	5.68e-06	-9.35e-06	0.0
66	6	-6.31e-03	-3.46e-03	-0.16	4.53e-05	-5.66e-05	1.26e-05
66	24	-4.89e-04	7.93e-03	-0.17	-1.30e-04	-2.19e-05	-1.78e-05
66	34	2.85e-03	7.93e-03	-0.17	-1.29e-04	7.72e-06	-1.78e-05
66	38	-2.64e-03	-1.44e-03	-0.16	2.23e-05	-2.75e-05	5.25e-06
66	56	-2.12e-04	3.31e-03	-0.17	-5.10e-05	-1.31e-05	-7.40e-06
66	66	1.18e-03	3.31e-03	-0.16	-5.06e-05	0.0	-7.42e-06
67	1	-1.60e-05	0.0	-0.23	0.0	-1.76e-05	0.0
67	2	-1.15e-05	0.0	-0.17	0.0	-1.07e-05	0.0
67	3	-5.56e-03	-8.13e-06	-0.17	3.63e-05	-4.80e-05	0.0
67	5	-5.56e-03	-2.41e-03	-0.17	3.67e-05	-4.80e-05	0.0
67	28	1.65e-03	-7.92e-03	-0.16	1.23e-04	3.75e-06	0.0
67	35	-2.32e-03	-4.68e-06	-0.16	1.52e-05	-2.48e-05	0.0
67	37	-2.32e-03	-1.00e-03	-0.16	1.53e-05	-2.48e-05	0.0
67	60	6.80e-04	-3.31e-03	-0.16	5.12e-05	-3.22e-06	0.0
68	1	-1.98e-05	7.89e-06	-0.23	5.82e-06	-1.56e-05	0.0
68	2	-1.43e-05	5.61e-06	-0.17	4.15e-06	-9.25e-06	0.0
68	6	-6.20e-03	-3.46e-03	-0.17	4.19e-05	-4.78e-05	0.0
68	24	-6.60e-04	7.93e-03	-0.17	-1.23e-04	-1.92e-05	0.0
68	34	2.67e-03	7.93e-03	-0.17	-1.22e-04	5.44e-06	0.0
68	38	-2.59e-03	-1.44e-03	-0.16	2.01e-05	-2.38e-05	0.0
68	56	-2.83e-04	3.31e-03	-0.17	-4.87e-05	-1.19e-05	0.0
68	66	1.10e-03	3.31e-03	-0.16	-4.85e-05	-1.63e-06	0.0
69	1	-1.97e-05	-8.14e-06	-0.23	-7.97e-06	-1.57e-05	0.0
69	2	-1.41e-05	-5.78e-06	-0.17	-5.68e-06	-9.35e-06	0.0
69	8	-6.31e-03	3.46e-03	-0.16	-4.53e-05	-5.66e-05	-1.26e-05
69	22	-4.89e-04	-7.93e-03	-0.17	1.30e-04	-2.19e-05	1.78e-05
69	28	2.85e-03	-7.93e-03	-0.17	1.29e-04	7.72e-06	1.78e-05
69	40	-2.64e-03	1.44e-03	-0.16	-2.23e-05	-2.75e-05	-5.25e-06
69	54	-2.12e-04	-3.31e-03	-0.17	5.10e-05	-1.31e-05	7.40e-06
69	60	1.18e-03	-3.31e-03	-0.16	5.06e-05	0.0	7.42e-06
70	1	-1.98e-05	-7.89e-06	-0.23	-5.82e-06	-1.56e-05	0.0
70	2	-1.43e-05	-5.61e-06	-0.17	-4.15e-06	-9.25e-06	0.0
70	8	-6.20e-03	3.46e-03	-0.17	-4.19e-05	-4.78e-05	0.0
70	22	-6.60e-04	-7.93e-03	-0.17	1.23e-04	-1.92e-05	0.0
70	28	2.67e-03	-7.93e-03	-0.17	1.22e-04	5.44e-06	0.0
70	40	-2.59e-03	1.44e-03	-0.16	-2.01e-05	-2.38e-05	0.0

70	54	-2.83e-04	-3.31e-03	-0.17	4.87e-05	-1.19e-05	0.0
70	60	1.10e-03	-3.31e-03	-0.16	4.85e-05	-1.63e-06	0.0
71	1	-6.16e-03	0.0	-0.22	0.0	-7.68e-05	0.0
71	2	-4.32e-03	0.0	-0.16	0.0	-5.38e-05	0.0
71	8	-0.01	3.92e-03	-0.15	-3.67e-05	-9.76e-05	-1.25e-05
71	19	-7.86e-03	-0.02	-0.16	1.23e-04	-6.85e-05	-1.75e-05
71	29	-2.55e-03	-0.02	-0.16	1.23e-04	-4.37e-05	-1.75e-05
71	40	-8.39e-03	1.64e-03	-0.16	-1.54e-05	-7.35e-05	-5.20e-06
71	51	-5.91e-03	-6.80e-03	-0.16	5.13e-05	-6.14e-05	-7.29e-06
71	61	-3.70e-03	-6.80e-03	-0.16	5.13e-05	-5.11e-05	-7.29e-06
72	1	-6.16e-03	0.0	-0.21	0.0	-7.73e-05	0.0
72	2	-4.32e-03	0.0	-0.16	0.0	-5.42e-05	0.0
72	6	-0.01	-3.01e-03	-0.15	3.68e-05	-9.82e-05	1.25e-05
72	15	3.91e-03	6.26e-03	-0.16	-3.73e-05	-1.53e-05	1.25e-05
72	25	-7.86e-03	0.02	-0.16	-1.24e-04	-6.90e-05	1.75e-05
72	38	-8.39e-03	-1.26e-03	-0.15	1.55e-05	-7.40e-05	5.22e-06
72	47	-1.02e-03	2.61e-03	-0.16	-1.55e-05	-3.95e-05	5.21e-06
72	57	-5.91e-03	7.30e-03	-0.15	-5.16e-05	-6.19e-05	7.31e-06
73	1	-6.16e-03	0.0	-0.21	0.0	-7.73e-05	0.0
73	2	-4.32e-03	0.0	-0.16	0.0	-5.42e-05	0.0
73	8	-0.01	3.01e-03	-0.15	-3.68e-05	-9.82e-05	-1.25e-05
73	13	3.91e-03	-6.26e-03	-0.16	3.73e-05	-1.53e-05	-1.25e-05
73	19	-7.86e-03	-0.02	-0.16	1.24e-04	-6.90e-05	-1.75e-05
73	40	-8.39e-03	1.26e-03	-0.15	-1.55e-05	-7.40e-05	-5.22e-06
73	45	-1.02e-03	-2.61e-03	-0.16	1.55e-05	-3.95e-05	-5.21e-06
73	51	-5.91e-03	-7.30e-03	-0.15	5.16e-05	-6.19e-05	-7.31e-06
74	1	-2.85e-03	0.0	-0.23	0.0	-2.36e-05	0.0
74	2	-1.80e-03	0.0	-0.17	0.0	-1.50e-05	0.0
74	3	-0.01	-5.11e-03	-0.16	3.63e-05	-5.11e-05	0.0
74	9	-0.01	5.11e-03	-0.16	-3.63e-05	-5.11e-05	0.0
74	24	-4.57e-03	0.02	-0.16	-1.23e-04	-2.41e-05	0.0
74	35	-5.75e-03	-2.13e-03	-0.16	1.51e-05	-2.86e-05	0.0
74	41	-5.75e-03	2.13e-03	-0.16	-1.51e-05	-2.86e-05	0.0
74	56	-2.78e-03	8.99e-03	-0.16	-5.12e-05	-1.74e-05	0.0
75	1	-6.16e-03	0.0	-0.22	0.0	-7.68e-05	0.0
75	2	-4.32e-03	0.0	-0.16	0.0	-5.38e-05	0.0
75	6	-0.01	-3.92e-03	-0.15	3.67e-05	-9.76e-05	1.25e-05
75	25	-7.86e-03	0.02	-0.16	-1.23e-04	-6.85e-05	1.75e-05
75	31	-2.55e-03	0.02	-0.16	-1.23e-04	-4.37e-05	1.75e-05
75	38	-8.39e-03	-1.64e-03	-0.16	1.54e-05	-7.35e-05	5.20e-06
75	57	-5.91e-03	6.80e-03	-0.16	-5.13e-05	-6.14e-05	7.29e-06
75	63	-3.70e-03	6.80e-03	-0.16	-5.13e-05	-5.11e-05	7.29e-06
76	1	-2.85e-03	0.0	-0.22	0.0	-2.46e-05	0.0
76	2	-1.80e-03	0.0	-0.16	0.0	-1.56e-05	0.0
76	6	-0.01	-6.37e-03	-0.16	3.70e-05	-5.25e-05	1.25e-05
76	24	-3.55e-03	0.02	-0.17	-1.22e-04	-2.53e-05	-1.76e-05
76	34	2.57e-03	0.02	-0.17	-1.22e-04	-1.78e-06	-1.76e-05
76	38	-6.02e-03	-2.66e-03	-0.16	1.57e-05	-2.96e-05	5.23e-06
76	56	-2.36e-03	8.62e-03	-0.16	-5.09e-05	-1.83e-05	-7.34e-06
76	66	1.87e-04	8.62e-03	-0.16	-5.08e-05	-8.51e-06	-7.34e-06
77	1	-2.85e-03	0.0	-0.22	0.0	-2.46e-05	0.0
77	2	-1.80e-03	0.0	-0.16	0.0	-1.56e-05	0.0
77	8	-0.01	6.37e-03	-0.16	-3.70e-05	-5.25e-05	-1.25e-05
77	22	-3.55e-03	-0.02	-0.17	1.22e-04	-2.53e-05	1.76e-05
77	28	2.57e-03	-0.02	-0.17	1.22e-04	-1.78e-06	1.76e-05
77	40	-6.02e-03	2.66e-03	-0.16	-1.57e-05	-2.96e-05	-5.23e-06

77	54	-2.36e-03	-8.62e-03	-0.16	5.09e-05	-1.83e-05	7.34e-06
77	60	1.87e-04	-8.62e-03	-0.16	5.08e-05	-8.51e-06	7.34e-06
78	1	-2.85e-03	0.0	-0.23	0.0	-2.34e-05	0.0
78	2	-1.80e-03	0.0	-0.17	0.0	-1.48e-05	0.0
78	8	-0.01	7.78e-03	-0.16	-3.74e-05	-5.18e-05	-1.25e-05
78	22	-3.55e-03	-0.02	-0.17	1.23e-04	-2.46e-05	1.77e-05
78	28	2.57e-03	-0.02	-0.17	1.23e-04	0.0	1.77e-05
78	40	-6.02e-03	3.25e-03	-0.16	-1.59e-05	-2.88e-05	-5.19e-06
78	54	-2.36e-03	-9.37e-03	-0.17	5.12e-05	-1.75e-05	7.39e-06
78	60	1.87e-04	-9.37e-03	-0.16	5.12e-05	-7.60e-06	7.39e-06
79	1	-2.85e-03	0.0	-0.23	0.0	-2.34e-05	0.0
79	2	-1.80e-03	0.0	-0.17	0.0	-1.48e-05	0.0
79	6	-0.01	-7.78e-03	-0.16	3.74e-05	-5.18e-05	1.25e-05
79	24	-3.55e-03	0.02	-0.17	-1.23e-04	-2.46e-05	-1.77e-05
79	34	2.57e-03	0.02	-0.17	-1.23e-04	0.0	-1.77e-05
79	38	-6.02e-03	-3.25e-03	-0.16	1.59e-05	-2.88e-05	5.19e-06
79	56	-2.36e-03	9.37e-03	-0.17	-5.12e-05	-1.75e-05	-7.39e-06
79	66	1.87e-04	9.37e-03	-0.16	-5.12e-05	-7.60e-06	-7.39e-06
80	1	-0.01	0.0	-0.21	-6.02e-06	-3.32e-05	0.0
80	2	-6.90e-03	0.0	-0.16	-4.26e-06	-2.20e-05	0.0
80	9	-0.16	0.07	-0.15	-4.97e-04	-1.09e-03	1.54e-04
80	19	-0.04	-0.19	-0.14	1.31e-03	-2.24e-04	-2.01e-04
80	31	0.02	0.19	-0.16	-1.32e-03	1.82e-04	2.01e-04
80	41	-0.07	0.03	-0.15	-2.10e-04	-4.65e-04	6.40e-05
80	51	-0.02	-0.08	-0.15	5.44e-04	-1.05e-04	-8.36e-05
80	63	4.95e-03	0.08	-0.16	-5.52e-04	6.37e-05	8.36e-05
81	1	-1.89e-05	4.39e-06	-0.23	3.19e-06	-1.53e-05	0.0
81	2	-1.36e-05	3.12e-06	-0.17	2.28e-06	-9.06e-06	0.0
81	6	-5.98e-03	-3.59e-03	-0.17	3.88e-05	-4.73e-05	0.0
81	8	-5.15e-03	3.59e-03	-0.17	-3.56e-05	-4.71e-05	0.0
81	34	2.33e-03	8.08e-03	-0.16	-1.21e-04	5.77e-06	0.0
81	38	-2.50e-03	-1.49e-03	-0.16	1.76e-05	-2.35e-05	0.0
81	40	-2.15e-03	1.50e-03	-0.16	-1.35e-05	-2.34e-05	0.0
81	66	9.62e-04	3.38e-03	-0.16	-4.90e-05	-1.43e-06	0.0
82	1	1.88e-05	5.68e-06	-0.21	7.17e-06	-8.53e-05	0.0
82	2	1.36e-05	4.00e-06	-0.16	5.09e-06	-5.99e-05	0.0
82	15	5.15e-03	3.56e-03	-0.16	-3.32e-05	-1.90e-05	0.0
82	18	5.98e-03	-8.83e-05	-0.16	-3.25e-05	-1.89e-05	0.0
82	25	-2.33e-03	8.01e-03	-0.15	-1.19e-04	-7.55e-05	0.0
82	47	2.15e-03	1.49e-03	-0.15	-1.07e-05	-4.46e-05	0.0
82	50	2.50e-03	-3.31e-05	-0.15	-1.04e-05	-4.45e-05	0.0
82	57	-9.60e-04	3.35e-03	-0.15	-4.66e-05	-6.81e-05	0.0
83	1	-1.89e-05	-4.39e-06	-0.23	-3.19e-06	-1.53e-05	0.0
83	2	-1.36e-05	-3.12e-06	-0.17	-2.28e-06	-9.06e-06	0.0
83	6	-5.15e-03	-3.59e-03	-0.17	3.56e-05	-4.71e-05	0.0
83	8	-5.98e-03	3.59e-03	-0.17	-3.88e-05	-4.73e-05	0.0
83	28	2.33e-03	-8.08e-03	-0.16	1.21e-04	5.77e-06	0.0
83	38	-2.15e-03	-1.50e-03	-0.16	1.35e-05	-2.34e-05	0.0
83	40	-2.50e-03	1.49e-03	-0.16	-1.76e-05	-2.35e-05	0.0
83	60	9.62e-04	-3.38e-03	-0.16	4.90e-05	-1.43e-06	0.0
84	1	1.88e-05	-5.68e-06	-0.21	-7.17e-06	-8.53e-05	0.0
84	2	1.36e-05	-4.00e-06	-0.16	-5.09e-06	-5.99e-05	0.0
84	12	5.98e-03	8.83e-05	-0.16	3.25e-05	-1.89e-05	0.0
84	13	5.15e-03	-3.56e-03	-0.16	3.32e-05	-1.90e-05	0.0
84	19	-2.33e-03	-8.01e-03	-0.15	1.19e-04	-7.55e-05	0.0
84	44	2.50e-03	3.31e-05	-0.15	1.04e-05	-4.45e-05	0.0

84	45	2.15e-03	-1.49e-03	-0.15	1.07e-05	-4.46e-05	0.0
84	51	-9.60e-04	-3.35e-03	-0.15	4.66e-05	-6.81e-05	0.0
85	1	1.99e-05	-6.83e-06	-0.21	-6.50e-06	-8.44e-05	0.0
85	2	1.43e-05	-4.80e-06	-0.16	-4.60e-06	-5.92e-05	0.0
85	12	5.98e-03	-1.72e-05	-0.16	3.26e-05	-1.88e-05	0.0
85	13	5.15e-03	-3.44e-03	-0.16	3.32e-05	-1.88e-05	0.0
85	19	-2.33e-03	-7.86e-03	-0.16	1.19e-04	-7.47e-05	0.0
85	44	2.50e-03	-1.14e-05	-0.16	1.07e-05	-4.41e-05	0.0
85	45	2.15e-03	-1.44e-03	-0.16	1.10e-05	-4.41e-05	0.0
85	51	-9.59e-04	-3.28e-03	-0.15	4.70e-05	-6.73e-05	0.0
86	1	-2.04e-05	-6.19e-06	-0.23	-1.82e-06	-1.88e-05	0.0
86	2	-1.46e-05	-4.39e-06	-0.17	-1.31e-06	-1.15e-05	0.0
86	6	-5.15e-03	-3.35e-03	-0.17	3.60e-05	-4.84e-05	1.22e-05
86	8	-5.98e-03	3.34e-03	-0.17	-3.81e-05	-4.84e-05	-1.29e-05
86	28	2.33e-03	-7.76e-03	-0.16	1.22e-04	2.75e-06	1.74e-05
86	38	-2.15e-03	-1.40e-03	-0.16	1.42e-05	-2.54e-05	4.87e-06
86	40	-2.50e-03	1.39e-03	-0.16	-1.67e-05	-2.54e-05	-5.56e-06
86	60	9.61e-04	-3.24e-03	-0.16	5.00e-05	-4.12e-06	7.04e-06
87	1	-1.94e-05	-5.00e-06	-0.23	-2.49e-06	-1.66e-05	0.0
87	2	-1.40e-05	-3.55e-06	-0.17	-1.78e-06	-9.97e-06	0.0
87	6	-5.15e-03	-3.47e-03	-0.17	3.57e-05	-4.76e-05	0.0
87	8	-5.98e-03	3.46e-03	-0.17	-3.85e-05	-4.78e-05	0.0
87	28	2.33e-03	-7.92e-03	-0.16	1.21e-04	4.75e-06	0.0
87	38	-2.15e-03	-1.45e-03	-0.16	1.38e-05	-2.42e-05	0.0
87	40	-2.50e-03	1.44e-03	-0.16	-1.72e-05	-2.42e-05	0.0
87	60	9.62e-04	-3.31e-03	-0.16	4.95e-05	-2.37e-06	0.0
88	1	2.20e-05	-1.04e-05	-0.21	-4.98e-06	-8.16e-05	0.0
88	2	1.59e-05	-7.28e-06	-0.16	-3.51e-06	-5.73e-05	0.0
88	12	5.99e-03	-1.26e-04	-0.16	3.35e-05	-1.80e-05	1.27e-05
88	13	5.15e-03	-3.32e-03	-0.16	3.39e-05	-1.80e-05	-1.24e-05
88	29	1.01e-03	-7.70e-03	-0.16	1.21e-04	-4.72e-05	-1.75e-05
88	44	2.50e-03	-5.82e-05	-0.16	1.18e-05	-4.26e-05	5.30e-06
88	45	2.15e-03	-1.39e-03	-0.16	1.20e-05	-4.25e-05	-5.13e-06
88	61	4.29e-04	-3.22e-03	-0.16	4.82e-05	-5.47e-05	-7.29e-06
89	1	1.25e-05	-5.08e-06	-0.22	-4.81e-06	-7.74e-05	0.0
89	2	9.07e-06	-3.46e-06	-0.16	-3.37e-06	-5.42e-05	0.0
89	12	5.98e-03	-5.56e-04	-0.16	3.32e-05	-1.56e-05	1.25e-05
89	29	1.00e-03	-7.07e-03	-0.16	1.20e-04	-4.43e-05	-1.74e-05
89	44	2.50e-03	-2.35e-04	-0.16	1.19e-05	-3.97e-05	5.25e-06
89	61	4.22e-04	-2.95e-03	-0.16	4.82e-05	-5.16e-05	-7.23e-06
90	1	-1.43e-06	-9.65e-06	-0.22	-4.22e-06	-7.05e-05	0.0
90	2	-1.01e-06	-6.70e-06	-0.16	-2.95e-06	-4.92e-05	0.0
90	8	-5.97e-03	9.90e-04	-0.15	-3.96e-05	-9.19e-05	-1.23e-05
90	29	9.89e-04	-6.46e-03	-0.16	1.20e-04	-3.86e-05	-1.74e-05
90	40	-2.49e-03	4.10e-04	-0.16	-1.83e-05	-6.82e-05	-5.09e-06
90	61	4.11e-04	-2.70e-03	-0.16	4.84e-05	-4.60e-05	-7.18e-06
91	1	7.74e-06	-7.62e-06	-0.22	-1.71e-06	-3.25e-05	0.0
91	2	5.59e-06	-5.35e-06	-0.16	-1.22e-06	-2.14e-05	0.0
91	12	5.98e-03	-1.92e-03	-0.16	3.58e-05	1.87e-05	1.30e-05
91	22	-9.78e-04	-5.89e-03	-0.17	1.22e-04	-3.12e-05	1.82e-05
91	44	2.49e-03	-8.06e-04	-0.16	1.42e-05	-3.76e-06	5.70e-06
91	54	-4.03e-04	-2.46e-03	-0.16	5.01e-05	-2.45e-05	7.86e-06
92	1	-8.20e-06	-4.26e-06	-0.23	-3.38e-06	-2.34e-05	0.0
92	2	-5.95e-06	-2.95e-06	-0.17	-2.47e-06	-1.48e-05	0.0
92	8	-5.98e-03	2.62e-03	-0.16	-3.93e-05	-5.08e-05	0.0
92	22	-9.90e-04	-6.81e-03	-0.17	1.20e-04	-2.39e-05	0.0

92	40	-2.49e-03	1.09e-03	-0.16	-1.79e-05	-2.83e-05	0.0
92	54	-4.15e-04	-2.85e-03	-0.16	4.88e-05	-1.71e-05	0.0
93	1	1.99e-05	6.83e-06	-0.21	6.50e-06	-8.44e-05	0.0
93	2	1.43e-05	4.80e-06	-0.16	4.60e-06	-5.92e-05	0.0
93	15	5.15e-03	3.44e-03	-0.16	-3.32e-05	-1.88e-05	0.0
93	18	5.98e-03	1.72e-05	-0.16	-3.26e-05	-1.88e-05	0.0
93	25	-2.33e-03	7.86e-03	-0.16	-1.19e-04	-7.47e-05	0.0
93	47	2.15e-03	1.44e-03	-0.16	-1.10e-05	-4.41e-05	0.0
93	50	2.50e-03	1.14e-05	-0.16	-1.07e-05	-4.41e-05	0.0
93	57	-9.59e-04	3.28e-03	-0.15	-4.70e-05	-6.73e-05	0.0
94	1	-2.04e-05	6.19e-06	-0.23	1.82e-06	-1.88e-05	0.0
94	2	-1.46e-05	4.39e-06	-0.17	1.31e-06	-1.15e-05	0.0
94	6	-5.98e-03	-3.34e-03	-0.17	3.81e-05	-4.84e-05	1.29e-05
94	8	-5.15e-03	3.35e-03	-0.17	-3.60e-05	-4.84e-05	-1.22e-05
94	34	2.33e-03	7.76e-03	-0.16	-1.22e-04	2.75e-06	-1.74e-05
94	38	-2.50e-03	-1.39e-03	-0.16	1.67e-05	-2.54e-05	5.56e-06
94	40	-2.15e-03	1.40e-03	-0.16	-1.42e-05	-2.54e-05	-4.87e-06
94	66	9.61e-04	3.24e-03	-0.16	-5.00e-05	-4.12e-06	-7.04e-06
95	1	-1.94e-05	5.00e-06	-0.23	2.49e-06	-1.66e-05	0.0
95	2	-1.40e-05	3.55e-06	-0.17	1.78e-06	-9.97e-06	0.0
95	6	-5.98e-03	-3.46e-03	-0.17	3.85e-05	-4.78e-05	0.0
95	8	-5.15e-03	3.47e-03	-0.17	-3.57e-05	-4.76e-05	0.0
95	34	2.33e-03	7.92e-03	-0.16	-1.21e-04	4.75e-06	0.0
95	38	-2.50e-03	-1.44e-03	-0.16	1.72e-05	-2.42e-05	0.0
95	40	-2.15e-03	1.45e-03	-0.16	-1.38e-05	-2.42e-05	0.0
95	66	9.62e-04	3.31e-03	-0.16	-4.95e-05	-2.37e-06	0.0
96	1	2.20e-05	1.04e-05	-0.21	4.98e-06	-8.16e-05	0.0
96	2	1.59e-05	7.28e-06	-0.16	3.51e-06	-5.73e-05	0.0
96	15	5.15e-03	3.32e-03	-0.16	-3.39e-05	-1.80e-05	1.24e-05
96	18	5.99e-03	1.26e-04	-0.16	-3.35e-05	-1.80e-05	-1.27e-05
96	31	1.01e-03	7.70e-03	-0.16	-1.21e-04	-4.72e-05	1.75e-05
96	47	2.15e-03	1.39e-03	-0.16	-1.20e-05	-4.25e-05	5.13e-06
96	50	2.50e-03	5.82e-05	-0.16	-1.18e-05	-4.26e-05	-5.30e-06
96	63	4.29e-04	3.22e-03	-0.16	-4.82e-05	-5.47e-05	7.29e-06
97	1	1.25e-05	5.08e-06	-0.22	4.81e-06	-7.74e-05	0.0
97	2	9.07e-06	3.46e-06	-0.16	3.37e-06	-5.42e-05	0.0
97	18	5.98e-03	5.56e-04	-0.16	-3.32e-05	-1.56e-05	-1.25e-05
97	31	1.00e-03	7.07e-03	-0.16	-1.20e-04	-4.43e-05	1.74e-05
97	50	2.50e-03	2.35e-04	-0.16	-1.19e-05	-3.97e-05	-5.25e-06
97	63	4.22e-04	2.95e-03	-0.16	-4.82e-05	-5.16e-05	7.23e-06
98	1	-1.43e-06	9.65e-06	-0.22	4.22e-06	-7.05e-05	0.0
98	2	-1.01e-06	6.70e-06	-0.16	2.95e-06	-4.92e-05	0.0
98	6	-5.97e-03	-9.90e-04	-0.15	3.96e-05	-9.19e-05	1.23e-05
98	31	9.89e-04	6.46e-03	-0.16	-1.20e-04	-3.86e-05	1.74e-05
98	38	-2.49e-03	-4.10e-04	-0.16	1.83e-05	-6.82e-05	5.09e-06
98	63	4.11e-04	2.70e-03	-0.16	-4.84e-05	-4.60e-05	7.18e-06
99	1	7.74e-06	7.62e-06	-0.22	1.71e-06	-3.25e-05	0.0
99	2	5.59e-06	5.35e-06	-0.16	1.22e-06	-2.14e-05	0.0
99	18	5.98e-03	1.92e-03	-0.16	-3.58e-05	1.87e-05	-1.30e-05
99	24	-9.78e-04	5.89e-03	-0.17	-1.22e-04	-3.12e-05	-1.82e-05
99	50	2.49e-03	8.06e-04	-0.16	-1.42e-05	-3.76e-06	-5.70e-06
99	56	-4.03e-04	2.46e-03	-0.16	-5.01e-05	-2.45e-05	-7.86e-06
100	1	-8.20e-06	4.26e-06	-0.23	3.38e-06	-2.34e-05	0.0
100	2	-5.95e-06	2.95e-06	-0.17	2.47e-06	-1.48e-05	0.0
100	6	-5.98e-03	-2.62e-03	-0.16	3.93e-05	-5.08e-05	0.0
100	24	-9.90e-04	6.81e-03	-0.17	-1.20e-04	-2.39e-05	0.0

100	38	-2.49e-03	-1.09e-03	-0.16	1.79e-05	-2.83e-05	0.0
100	56	-4.15e-04	2.85e-03	-0.16	-4.88e-05	-1.71e-05	0.0
101	1	-0.01	0.0	-0.23	-3.92e-06	-6.74e-05	0.0
101	2	-6.90e-03	0.0	-0.17	-2.79e-06	-4.69e-05	0.0
101	9	-0.16	0.02	-0.17	-1.65e-04	-1.12e-03	1.54e-04
101	24	-0.04	0.19	-0.17	-1.31e-03	-2.54e-04	-1.98e-04
101	28	0.02	-0.19	-0.15	1.31e-03	1.57e-04	1.98e-04
101	41	-0.07	0.01	-0.17	-7.06e-05	-4.94e-04	6.40e-05
101	56	-0.02	0.08	-0.17	-5.50e-04	-1.34e-04	-8.26e-05
101	60	5.02e-03	-0.08	-0.16	5.44e-04	3.69e-05	8.26e-05
102	1	-0.01	0.0	-0.23	3.92e-06	-6.74e-05	0.0
102	2	-6.90e-03	0.0	-0.17	2.79e-06	-4.69e-05	0.0
102	3	-0.16	-0.02	-0.17	1.65e-04	-1.12e-03	-1.54e-04
102	22	-0.04	-0.19	-0.17	1.31e-03	-2.54e-04	1.98e-04
102	34	0.02	0.19	-0.15	-1.31e-03	1.57e-04	-1.98e-04
102	35	-0.07	-0.01	-0.17	7.06e-05	-4.94e-04	-6.40e-05
102	54	-0.02	-0.08	-0.17	5.50e-04	-1.34e-04	8.26e-05
102	66	5.02e-03	0.08	-0.16	-5.44e-04	3.69e-05	-8.26e-05
103	1	-0.01	0.0	-0.21	6.02e-06	-3.32e-05	0.0
103	2	-6.90e-03	0.0	-0.16	4.26e-06	-2.20e-05	0.0
103	3	-0.16	-0.07	-0.15	4.97e-04	-1.09e-03	-1.54e-04
103	25	-0.04	0.19	-0.14	-1.31e-03	-2.24e-04	2.01e-04
103	29	0.02	-0.19	-0.16	1.32e-03	1.82e-04	-2.01e-04
103	35	-0.07	-0.03	-0.15	2.10e-04	-4.65e-04	-6.40e-05
103	57	-0.02	0.08	-0.15	-5.44e-04	-1.05e-04	8.36e-05
103	61	4.95e-03	-0.08	-0.16	5.52e-04	6.37e-05	-8.36e-05
104	1	-1.43e-03	0.0	-0.22	-1.41e-06	-2.58e-05	0.0
104	2	-9.04e-04	0.0	-0.16	0.0	-1.65e-05	0.0
104	8	-9.26e-03	4.14e-03	-0.16	-3.82e-05	-5.25e-05	-1.25e-05
104	22	-2.10e-03	-0.01	-0.17	1.22e-04	-2.55e-05	1.78e-05
104	28	2.63e-03	-0.01	-0.17	1.22e-04	-2.62e-06	1.78e-05
104	40	-4.30e-03	1.73e-03	-0.16	-1.65e-05	-3.02e-05	-5.15e-06
104	54	-1.32e-03	-5.54e-03	-0.16	5.03e-05	-1.89e-05	7.44e-06
104	60	6.50e-04	-5.54e-03	-0.16	5.04e-05	-9.43e-06	7.44e-06
105	1	-3.08e-03	0.0	-0.22	0.0	-7.60e-05	0.0
105	2	-2.16e-03	0.0	-0.16	0.0	-5.32e-05	0.0
105	8	-9.88e-03	2.46e-03	-0.15	-3.70e-05	-9.72e-05	-1.26e-05
105	19	-5.10e-03	-0.01	-0.16	1.23e-04	-6.85e-05	-1.76e-05
105	29	-7.75e-04	-0.01	-0.16	1.23e-04	-4.36e-05	-1.76e-05
105	40	-5.43e-03	1.03e-03	-0.16	-1.57e-05	-7.30e-05	-5.26e-06
105	51	-3.44e-03	-4.75e-03	-0.16	5.11e-05	-6.10e-05	-7.36e-06
105	61	-1.64e-03	-4.75e-03	-0.16	5.11e-05	-5.07e-05	-7.35e-06
106	1	-1.43e-03	0.0	-0.22	1.41e-06	-2.58e-05	0.0
106	2	-9.04e-04	0.0	-0.16	0.0	-1.65e-05	0.0
106	6	-9.26e-03	-4.14e-03	-0.16	3.82e-05	-5.25e-05	1.25e-05
106	24	-2.10e-03	0.01	-0.17	-1.22e-04	-2.55e-05	-1.78e-05
106	34	2.63e-03	0.01	-0.17	-1.22e-04	-2.62e-06	-1.78e-05
106	38	-4.30e-03	-1.73e-03	-0.16	1.65e-05	-3.02e-05	5.15e-06
106	56	-1.32e-03	5.54e-03	-0.16	-5.03e-05	-1.89e-05	-7.44e-06
106	66	6.50e-04	5.54e-03	-0.16	-5.04e-05	-9.43e-06	-7.44e-06
107	1	-1.43e-03	1.28e-06	-0.23	1.51e-06	-2.27e-05	0.0
107	2	-9.05e-04	0.0	-0.17	1.07e-06	-1.43e-05	0.0
107	6	-9.26e-03	-5.56e-03	-0.16	3.80e-05	-4.96e-05	1.26e-05
107	24	-2.10e-03	0.02	-0.17	-1.21e-04	-2.28e-05	-1.76e-05
107	38	-4.30e-03	-2.32e-03	-0.16	1.65e-05	-2.76e-05	5.24e-06
107	56	-1.32e-03	6.30e-03	-0.17	-4.97e-05	-1.64e-05	-7.33e-06

108	1	-1.43e-03	-1.27e-06	-0.23	-1.51e-06	-2.27e-05	0.0
108	2	-9.05e-04	0.0	-0.17	-1.07e-06	-1.43e-05	0.0
108	8	-9.26e-03	5.56e-03	-0.16	-3.80e-05	-4.96e-05	-1.26e-05
108	22	-2.10e-03	-0.02	-0.17	1.21e-04	-2.28e-05	1.76e-05
108	40	-4.30e-03	2.32e-03	-0.16	-1.65e-05	-2.76e-05	-5.24e-06
108	54	-1.32e-03	-6.30e-03	-0.17	4.97e-05	-1.64e-05	7.33e-06
109	1	-3.08e-03	0.0	-0.22	0.0	-7.60e-05	0.0
109	2	-2.16e-03	0.0	-0.16	0.0	-5.32e-05	0.0
109	6	-9.88e-03	-2.46e-03	-0.15	3.70e-05	-9.72e-05	1.26e-05
109	25	-5.10e-03	0.01	-0.16	-1.23e-04	-6.85e-05	1.76e-05
109	31	-7.75e-04	0.01	-0.16	-1.23e-04	-4.36e-05	1.76e-05
109	38	-5.43e-03	-1.03e-03	-0.16	1.57e-05	-7.30e-05	5.26e-06
109	57	-3.44e-03	4.75e-03	-0.16	-5.11e-05	-6.10e-05	7.36e-06
109	63	-1.64e-03	4.75e-03	-0.16	-5.11e-05	-5.07e-05	7.35e-06
110	1	-3.08e-03	0.0	-0.21	0.0	-7.79e-05	0.0
110	2	-2.16e-03	0.0	-0.16	0.0	-5.46e-05	0.0
110	6	-9.88e-03	-1.55e-03	-0.15	3.72e-05	-9.82e-05	1.25e-05
110	15	4.53e-03	4.78e-03	-0.16	-3.60e-05	-1.63e-05	1.25e-05
110	31	-7.73e-04	0.01	-0.16	-1.22e-04	-4.52e-05	1.75e-05
110	38	-5.43e-03	-6.49e-04	-0.15	1.59e-05	-7.43e-05	5.22e-06
110	47	5.66e-04	2.00e-03	-0.16	-1.47e-05	-4.02e-05	5.21e-06
110	63	-1.64e-03	5.25e-03	-0.16	-5.05e-05	-5.22e-05	7.30e-06
111	1	-3.08e-03	0.0	-0.21	0.0	-7.79e-05	0.0
111	2	-2.16e-03	0.0	-0.16	0.0	-5.46e-05	0.0
111	8	-9.88e-03	1.55e-03	-0.15	-3.72e-05	-9.82e-05	-1.25e-05
111	13	4.53e-03	-4.78e-03	-0.16	3.60e-05	-1.63e-05	-1.25e-05
111	29	-7.73e-04	-0.01	-0.16	1.22e-04	-4.52e-05	-1.75e-05
111	40	-5.43e-03	6.49e-04	-0.15	-1.59e-05	-7.43e-05	-5.22e-06
111	45	5.66e-04	-2.00e-03	-0.16	1.47e-05	-4.02e-05	-5.21e-06
111	61	-1.64e-03	-5.25e-03	-0.16	5.05e-05	-5.22e-05	-7.30e-06
112	1	-1.43e-03	-2.43e-06	-0.23	3.05e-06	-2.41e-05	0.0
112	2	-9.05e-04	-1.73e-06	-0.17	1.96e-06	-1.53e-05	0.0
112	6	-9.26e-03	-4.85e-03	-0.16	3.91e-05	-5.23e-05	1.26e-05
112	22	-4.15e-03	-0.01	-0.15	1.25e-04	-2.45e-05	1.77e-05
112	24	-2.10e-03	0.01	-0.17	-1.21e-04	-2.51e-05	-1.77e-05
112	38	-4.30e-03	-2.03e-03	-0.16	1.74e-05	-2.93e-05	5.23e-06
112	54	-2.17e-03	-5.92e-03	-0.16	5.32e-05	-1.78e-05	7.38e-06
112	56	-1.32e-03	5.91e-03	-0.16	-4.93e-05	-1.80e-05	-7.35e-06
113	1	-1.43e-03	2.43e-06	-0.23	-3.05e-06	-2.41e-05	0.0
113	2	-9.05e-04	1.73e-06	-0.17	-1.96e-06	-1.53e-05	0.0
113	8	-9.26e-03	4.85e-03	-0.16	-3.91e-05	-5.23e-05	-1.26e-05
113	22	-2.10e-03	-0.01	-0.17	1.21e-04	-2.51e-05	1.77e-05
113	24	-4.15e-03	0.01	-0.15	-1.25e-04	-2.45e-05	-1.77e-05
113	40	-4.30e-03	2.03e-03	-0.16	-1.74e-05	-2.93e-05	-5.23e-06
113	54	-1.32e-03	-5.91e-03	-0.16	4.93e-05	-1.80e-05	7.35e-06
113	56	-2.17e-03	5.92e-03	-0.16	-5.32e-05	-1.78e-05	-7.38e-06
114	1	-1.43e-03	0.0	-0.23	0.0	-2.20e-05	0.0
114	2	-9.05e-04	0.0	-0.17	0.0	-1.39e-05	0.0
114	3	-8.63e-03	-2.25e-03	-0.17	3.63e-05	-4.95e-05	-1.25e-05
114	5	-8.63e-03	-4.52e-03	-0.17	3.66e-05	-4.95e-05	3.43e-06
114	24	-3.12e-03	0.02	-0.16	-1.22e-04	-2.29e-05	-1.77e-05
114	35	-4.04e-03	-9.43e-04	-0.16	1.51e-05	-2.73e-05	-5.19e-06
114	37	-4.04e-03	-1.89e-03	-0.16	1.53e-05	-2.73e-05	1.42e-06
114	56	-1.74e-03	6.30e-03	-0.16	-5.10e-05	-1.62e-05	-7.36e-06
115	1	-1.43e-03	0.0	-0.22	0.0	-2.46e-05	0.0
115	2	-9.07e-04	0.0	-0.16	0.0	-1.55e-05	0.0

115	3	-8.63e-03	-3.61e-03	-0.16	3.63e-05	-5.21e-05	-1.25e-05
115	10	-8.63e-03	3.78e-03	-0.16	-3.66e-05	-5.21e-05	3.36e-06
115	24	-3.12e-03	0.01	-0.16	-1.23e-04	-2.47e-05	-1.77e-05
115	35	-4.04e-03	-1.51e-03	-0.16	1.52e-05	-2.93e-05	-5.18e-06
115	42	-4.04e-03	1.58e-03	-0.16	-1.53e-05	-2.93e-05	1.39e-06
115	56	-1.74e-03	5.54e-03	-0.16	-5.14e-05	-1.79e-05	-7.36e-06
116	1	-1.43e-03	0.0	-0.23	0.0	-2.37e-05	0.0
116	2	-9.05e-04	0.0	-0.17	0.0	-1.50e-05	0.0
116	3	-8.63e-03	-2.93e-03	-0.16	3.65e-05	-5.13e-05	0.0
116	9	-8.63e-03	2.93e-03	-0.16	-3.65e-05	-5.13e-05	0.0
116	24	-3.12e-03	0.01	-0.16	-1.23e-04	-2.42e-05	0.0
116	35	-4.04e-03	-1.22e-03	-0.16	1.52e-05	-2.87e-05	0.0
116	41	-4.04e-03	1.22e-03	-0.16	-1.52e-05	-2.87e-05	0.0
116	56	-1.74e-03	5.92e-03	-0.16	-5.14e-05	-1.74e-05	0.0
117	1	-1.43e-03	0.0	-0.23	0.0	-2.28e-05	0.0
117	2	-9.05e-04	0.0	-0.17	0.0	-1.44e-05	0.0
117	6	-8.21e-03	-5.56e-03	-0.17	3.73e-05	-5.00e-05	1.24e-05
117	8	-9.05e-03	5.56e-03	-0.17	-3.76e-05	-5.01e-05	-1.27e-05
117	34	9.19e-04	0.02	-0.15	-1.24e-04	0.0	-1.78e-05
117	38	-3.86e-03	-2.32e-03	-0.16	1.54e-05	-2.78e-05	5.10e-06
117	40	-4.21e-03	2.32e-03	-0.16	-1.58e-05	-2.78e-05	-5.33e-06
117	66	-6.20e-05	6.30e-03	-0.16	-5.19e-05	-7.22e-06	-7.48e-06
118	1	-1.43e-03	1.09e-06	-0.22	0.0	-2.45e-05	0.0
118	2	-9.05e-04	0.0	-0.16	0.0	-1.56e-05	0.0
118	8	-9.05e-03	4.14e-03	-0.16	-3.72e-05	-5.18e-05	-1.23e-05
118	22	-2.44e-03	-0.01	-0.17	1.23e-04	-2.48e-05	1.79e-05
118	24	-3.80e-03	0.01	-0.16	-1.23e-04	-2.47e-05	-1.75e-05
118	40	-4.21e-03	1.73e-03	-0.16	-1.56e-05	-2.92e-05	-5.00e-06
118	54	-1.46e-03	-5.54e-03	-0.16	5.11e-05	-1.80e-05	7.57e-06
118	56	-2.03e-03	5.54e-03	-0.16	-5.15e-05	-1.79e-05	-7.15e-06
119	1	-1.43e-03	1.18e-06	-0.23	-8.81e-06	-2.37e-05	0.0
119	2	-9.05e-04	0.0	-0.17	-5.88e-06	-1.50e-05	0.0
119	8	-9.05e-03	4.85e-03	-0.16	-4.34e-05	-5.14e-05	0.0
119	22	-2.44e-03	-0.01	-0.17	1.17e-04	-2.43e-05	0.0
119	24	-3.80e-03	0.01	-0.16	-1.29e-04	-2.41e-05	0.0
119	40	-4.21e-03	2.02e-03	-0.16	-2.16e-05	-2.87e-05	0.0
119	54	-1.46e-03	-5.91e-03	-0.16	4.53e-05	-1.75e-05	0.0
119	56	-2.03e-03	5.92e-03	-0.16	-5.72e-05	-1.74e-05	0.0
120	1	-1.43e-03	0.0	-0.23	0.0	-2.28e-05	0.0
120	2	-9.05e-04	0.0	-0.17	0.0	-1.44e-05	0.0
120	6	-9.05e-03	-5.56e-03	-0.17	3.76e-05	-5.01e-05	1.27e-05
120	8	-8.21e-03	5.56e-03	-0.17	-3.73e-05	-5.00e-05	-1.24e-05
120	28	9.19e-04	-0.02	-0.15	1.24e-04	0.0	1.78e-05
120	38	-4.21e-03	-2.32e-03	-0.16	1.58e-05	-2.78e-05	5.33e-06
120	40	-3.86e-03	2.32e-03	-0.16	-1.54e-05	-2.78e-05	-5.10e-06
120	60	-6.20e-05	-6.30e-03	-0.16	5.19e-05	-7.22e-06	7.48e-06
121	1	-1.43e-03	-1.09e-06	-0.22	0.0	-2.45e-05	0.0
121	2	-9.05e-04	0.0	-0.16	0.0	-1.56e-05	0.0
121	6	-9.05e-03	-4.14e-03	-0.16	3.72e-05	-5.18e-05	1.23e-05
121	22	-3.80e-03	-0.01	-0.16	1.23e-04	-2.47e-05	1.75e-05
121	24	-2.44e-03	0.01	-0.17	-1.23e-04	-2.48e-05	-1.79e-05
121	38	-4.21e-03	-1.73e-03	-0.16	1.56e-05	-2.92e-05	5.00e-06
121	54	-2.03e-03	-5.54e-03	-0.16	5.15e-05	-1.79e-05	7.15e-06
121	56	-1.46e-03	5.54e-03	-0.16	-5.11e-05	-1.80e-05	-7.57e-06
122	1	-1.43e-03	-1.18e-06	-0.23	8.81e-06	-2.37e-05	0.0
122	2	-9.05e-04	0.0	-0.17	5.88e-06	-1.50e-05	0.0

122	6	-9.05e-03	-4.85e-03	-0.16	4.34e-05	-5.14e-05	0.0
122	22	-3.80e-03	-0.01	-0.16	1.29e-04	-2.41e-05	0.0
122	24	-2.44e-03	0.01	-0.17	-1.17e-04	-2.43e-05	0.0
122	38	-4.21e-03	-2.02e-03	-0.16	2.16e-05	-2.87e-05	0.0
122	54	-2.03e-03	-5.92e-03	-0.16	5.72e-05	-1.74e-05	0.0
122	56	-1.46e-03	5.91e-03	-0.16	-4.53e-05	-1.75e-05	0.0
123	1	-3.08e-03	0.0	-0.21	0.0	-7.72e-05	0.0
123	2	-2.16e-03	0.0	-0.16	0.0	-5.41e-05	0.0
123	3	-9.46e-03	-4.78e-03	-0.15	3.74e-05	-9.76e-05	-1.25e-05
123	17	4.94e-03	2.56e-03	-0.16	-3.69e-05	-1.57e-05	-3.41e-06
123	31	-9.98e-05	0.01	-0.15	-1.24e-04	-4.44e-05	1.75e-05
123	35	-5.26e-03	-2.00e-03	-0.15	1.56e-05	-7.37e-05	-5.20e-06
123	49	7.37e-04	1.07e-03	-0.15	-1.54e-05	-3.96e-05	-1.41e-06
123	63	-1.36e-03	5.25e-03	-0.15	-5.18e-05	-5.15e-05	7.30e-06
124	1	-3.08e-03	0.0	-0.22	0.0	-7.71e-05	0.0
124	2	-2.16e-03	0.0	-0.16	0.0	-5.41e-05	0.0
124	3	-9.46e-03	-4.31e-03	-0.15	3.72e-05	-9.79e-05	0.0
124	17	4.94e-03	2.73e-03	-0.16	-3.68e-05	-1.54e-05	0.0
124	31	-9.86e-05	0.01	-0.16	-1.23e-04	-4.43e-05	0.0
124	35	-5.26e-03	-1.80e-03	-0.15	1.55e-05	-7.38e-05	0.0
124	49	7.38e-04	1.14e-03	-0.16	-1.54e-05	-3.95e-05	0.0
124	63	-1.36e-03	5.00e-03	-0.16	-5.16e-05	-5.15e-05	0.0
125	1	-3.07e-03	0.0	-0.22	0.0	-7.76e-05	0.0
125	2	-2.15e-03	0.0	-0.16	0.0	-5.45e-05	0.0
125	3	-9.45e-03	-3.84e-03	-0.15	3.70e-05	-9.88e-05	-1.25e-05
125	17	4.94e-03	2.89e-03	-0.16	-3.68e-05	-1.56e-05	-3.41e-06
125	31	-9.66e-05	0.01	-0.16	-1.23e-04	-4.47e-05	1.75e-05
125	35	-5.25e-03	-1.60e-03	-0.16	1.55e-05	-7.45e-05	-5.19e-06
125	49	7.40e-04	1.21e-03	-0.16	-1.54e-05	-3.99e-05	-1.41e-06
125	63	-1.36e-03	4.75e-03	-0.16	-5.14e-05	-5.20e-05	7.28e-06
126	1	-3.08e-03	2.19e-06	-0.22	0.0	-7.70e-05	0.0
126	2	-2.16e-03	1.55e-06	-0.16	0.0	-5.40e-05	0.0
126	8	-9.88e-03	2.00e-03	-0.15	-3.63e-05	-9.78e-05	-1.25e-05
126	29	-7.74e-04	-0.01	-0.16	1.23e-04	-4.38e-05	-1.75e-05
126	31	5.78e-04	0.01	-0.15	-1.23e-04	-4.45e-05	1.75e-05
126	40	-5.43e-03	8.38e-04	-0.15	-1.51e-05	-7.37e-05	-5.19e-06
126	61	-1.64e-03	-5.00e-03	-0.16	5.14e-05	-5.12e-05	-7.29e-06
126	63	-1.08e-03	5.00e-03	-0.15	-5.12e-05	-5.15e-05	7.31e-06
127	1	-3.08e-03	-2.19e-06	-0.22	0.0	-7.70e-05	0.0
127	2	-2.16e-03	-1.54e-06	-0.16	0.0	-5.40e-05	0.0
127	6	-9.88e-03	-2.00e-03	-0.15	3.63e-05	-9.78e-05	1.25e-05
127	29	5.78e-04	-0.01	-0.15	1.23e-04	-4.45e-05	-1.75e-05
127	31	-7.74e-04	0.01	-0.16	-1.23e-04	-4.38e-05	1.75e-05
127	38	-5.43e-03	-8.38e-04	-0.15	1.51e-05	-7.37e-05	5.19e-06
127	61	-1.08e-03	-5.00e-03	-0.15	5.12e-05	-5.15e-05	-7.31e-06
127	63	-1.64e-03	5.00e-03	-0.16	-5.14e-05	-5.12e-05	7.29e-06
128	1	-6.16e-03	0.0	-0.22	0.0	-7.71e-05	0.0
128	2	-4.32e-03	0.0	-0.16	0.0	-5.41e-05	0.0
128	8	-0.01	3.46e-03	-0.15	-3.68e-05	-9.79e-05	-1.25e-05
128	29	-2.55e-03	-0.02	-0.16	1.24e-04	-4.45e-05	-1.75e-05
128	31	-1.20e-03	0.02	-0.15	-1.23e-04	-4.40e-05	1.75e-05
128	40	-8.39e-03	1.45e-03	-0.15	-1.52e-05	-7.38e-05	-5.21e-06
128	61	-3.70e-03	-7.05e-03	-0.16	5.18e-05	-5.16e-05	-7.30e-06
128	63	-3.14e-03	7.05e-03	-0.15	-5.12e-05	-5.14e-05	7.30e-06
129	1	-6.16e-03	0.0	-0.22	0.0	-7.71e-05	0.0
129	2	-4.32e-03	0.0	-0.16	0.0	-5.41e-05	0.0

129	6	-0.01	-3.46e-03	-0.15	3.68e-05	-9.79e-05	1.25e-05
129	29	-1.20e-03	-0.02	-0.15	1.23e-04	-4.40e-05	-1.75e-05
129	31	-2.55e-03	0.02	-0.16	-1.24e-04	-4.45e-05	1.75e-05
129	38	-8.39e-03	-1.45e-03	-0.15	1.52e-05	-7.38e-05	5.21e-06
129	61	-3.14e-03	-7.05e-03	-0.15	5.12e-05	-5.14e-05	-7.30e-06
129	63	-3.70e-03	7.05e-03	-0.16	-5.18e-05	-5.16e-05	7.30e-06
130	1	-6.16e-03	0.0	-0.21	0.0	-7.69e-05	0.0
130	2	-4.32e-03	0.0	-0.16	0.0	-5.39e-05	0.0
130	3	-0.01	-6.26e-03	-0.15	3.68e-05	-9.80e-05	-1.25e-05
130	17	4.32e-03	4.03e-03	-0.16	-3.67e-05	-1.50e-05	-3.41e-06
130	31	-1.87e-03	0.02	-0.15	-1.22e-04	-4.40e-05	1.75e-05
130	35	-8.21e-03	-2.61e-03	-0.15	1.54e-05	-7.38e-05	-5.19e-06
130	49	-8.44e-04	1.68e-03	-0.15	-1.53e-05	-3.92e-05	-1.41e-06
130	63	-3.42e-03	7.30e-03	-0.15	-5.11e-05	-5.13e-05	7.29e-06
131	1	-6.16e-03	0.0	-0.22	0.0	-7.75e-05	0.0
131	2	-4.32e-03	0.0	-0.16	0.0	-5.43e-05	0.0
131	3	-0.01	-5.33e-03	-0.15	3.71e-05	-9.79e-05	-1.25e-05
131	17	4.32e-03	4.36e-03	-0.16	-3.68e-05	-1.59e-05	-3.41e-06
131	31	-1.87e-03	0.02	-0.16	-1.23e-04	-4.46e-05	1.75e-05
131	35	-8.21e-03	-2.22e-03	-0.16	1.55e-05	-7.40e-05	-5.20e-06
131	49	-8.44e-04	1.82e-03	-0.16	-1.54e-05	-3.98e-05	-1.41e-06
131	63	-3.42e-03	6.80e-03	-0.16	-5.15e-05	-5.18e-05	7.30e-06
132	1	-6.16e-03	0.0	-0.22	0.0	-7.72e-05	0.0
132	2	-4.32e-03	0.0	-0.16	0.0	-5.41e-05	0.0
132	3	-0.01	-5.79e-03	-0.15	3.70e-05	-9.80e-05	0.0
132	17	4.32e-03	4.19e-03	-0.16	-3.68e-05	-1.54e-05	0.0
132	31	-1.87e-03	0.02	-0.16	-1.23e-04	-4.43e-05	0.0
132	35	-8.21e-03	-2.42e-03	-0.15	1.55e-05	-7.39e-05	0.0
132	49	-8.44e-04	1.75e-03	-0.16	-1.54e-05	-3.95e-05	0.0
132	63	-3.42e-03	7.05e-03	-0.16	-5.14e-05	-5.16e-05	0.0
133	1	-2.85e-03	0.0	-0.22	0.0	-2.37e-05	0.0
133	2	-1.80e-03	0.0	-0.16	0.0	-1.50e-05	0.0
133	8	-0.01	6.37e-03	-0.16	-3.72e-05	-5.13e-05	-1.25e-05
133	22	-3.89e-03	-0.02	-0.17	1.23e-04	-2.41e-05	1.77e-05
133	28	2.23e-03	-0.02	-0.16	1.23e-04	0.0	1.77e-05
133	40	-5.93e-03	2.66e-03	-0.16	-1.56e-05	-2.87e-05	-5.19e-06
133	54	-2.50e-03	-8.62e-03	-0.16	5.13e-05	-1.74e-05	7.38e-06
133	60	4.44e-05	-8.62e-03	-0.16	5.13e-05	-7.76e-06	7.38e-06
134	1	-2.85e-03	0.0	-0.22	0.0	-2.32e-05	0.0
134	2	-1.80e-03	0.0	-0.16	0.0	-1.47e-05	0.0
134	3	-0.01	-5.80e-03	-0.16	3.64e-05	-5.05e-05	-1.25e-05
134	10	-0.01	5.98e-03	-0.16	-3.66e-05	-5.05e-05	3.36e-06
134	24	-4.57e-03	0.02	-0.16	-1.23e-04	-2.38e-05	-1.77e-05
134	35	-5.75e-03	-2.42e-03	-0.16	1.52e-05	-2.82e-05	-5.19e-06
134	42	-5.75e-03	2.50e-03	-0.16	-1.53e-05	-2.82e-05	1.39e-06
134	56	-2.78e-03	8.62e-03	-0.16	-5.13e-05	-1.71e-05	-7.36e-06
135	1	-2.85e-03	0.0	-0.22	0.0	-2.37e-05	0.0
135	2	-1.80e-03	0.0	-0.16	0.0	-1.50e-05	0.0
135	6	-0.01	-6.37e-03	-0.16	3.72e-05	-5.13e-05	1.25e-05
135	24	-3.89e-03	0.02	-0.17	-1.23e-04	-2.41e-05	-1.77e-05
135	34	2.23e-03	0.02	-0.16	-1.23e-04	0.0	-1.77e-05
135	38	-5.93e-03	-2.66e-03	-0.16	1.56e-05	-2.87e-05	5.19e-06
135	56	-2.50e-03	8.62e-03	-0.16	-5.13e-05	-1.74e-05	-7.38e-06
135	66	4.44e-05	8.62e-03	-0.16	-5.13e-05	-7.76e-06	-7.38e-06
136	1	-2.85e-03	0.0	-0.23	1.12e-06	-2.39e-05	0.0
136	2	-1.80e-03	0.0	-0.17	0.0	-1.52e-05	0.0

136	8	-0.01	7.07e-03	-0.16	-3.59e-05	-5.08e-05	-1.25e-05
136	22	-3.55e-03	-0.02	-0.17	1.24e-04	-2.39e-05	1.77e-05
136	34	5.22e-04	0.02	-0.15	-1.22e-04	-1.67e-06	-1.77e-05
136	40	-6.02e-03	2.95e-03	-0.16	-1.45e-05	-2.86e-05	-5.21e-06
136	54	-2.36e-03	-8.99e-03	-0.16	5.22e-05	-1.74e-05	7.37e-06
136	66	-6.66e-04	8.99e-03	-0.16	-5.06e-05	-8.17e-06	-7.36e-06
137	1	-2.85e-03	0.0	-0.23	-1.12e-06	-2.39e-05	0.0
137	2	-1.80e-03	0.0	-0.17	0.0	-1.52e-05	0.0
137	6	-0.01	-7.07e-03	-0.16	3.59e-05	-5.08e-05	1.25e-05
137	24	-3.55e-03	0.02	-0.17	-1.24e-04	-2.39e-05	-1.77e-05
137	28	5.22e-04	-0.02	-0.15	1.22e-04	-1.67e-06	1.77e-05
137	38	-6.02e-03	-2.95e-03	-0.16	1.45e-05	-2.86e-05	5.21e-06
137	56	-2.36e-03	8.99e-03	-0.16	-5.22e-05	-1.74e-05	-7.37e-06
137	60	-6.66e-04	-8.99e-03	-0.16	5.06e-05	-8.17e-06	7.36e-06
138	1	-2.85e-03	0.0	-0.23	0.0	-2.41e-05	0.0
138	2	-1.80e-03	0.0	-0.17	0.0	-1.53e-05	0.0
138	3	-0.01	-4.43e-03	-0.17	3.64e-05	-5.20e-05	-1.25e-05
138	5	-0.01	-6.72e-03	-0.17	3.70e-05	-5.20e-05	3.43e-06
138	24	-4.57e-03	0.02	-0.16	-1.24e-04	-2.46e-05	-1.77e-05
138	35	-5.75e-03	-1.85e-03	-0.16	1.52e-05	-2.91e-05	-5.19e-06
138	37	-5.75e-03	-2.81e-03	-0.16	1.55e-05	-2.91e-05	1.42e-06
138	56	-2.78e-03	9.37e-03	-0.16	-5.16e-05	-1.77e-05	-7.36e-06
139	1	-2.85e-03	0.0	-0.23	0.0	-2.36e-05	0.0
139	2	-1.80e-03	0.0	-0.17	0.0	-1.49e-05	0.0
139	6	-0.01	-7.78e-03	-0.17	3.69e-05	-5.16e-05	1.26e-05
139	8	-0.01	7.78e-03	-0.17	-3.64e-05	-5.17e-05	-1.25e-05
139	34	2.23e-03	0.02	-0.16	-1.22e-04	0.0	-1.77e-05
139	38	-5.93e-03	-3.25e-03	-0.16	1.55e-05	-2.88e-05	5.23e-06
139	40	-5.58e-03	3.25e-03	-0.16	-1.52e-05	-2.88e-05	-5.19e-06
139	66	4.46e-05	9.37e-03	-0.16	-5.10e-05	-7.67e-06	-7.34e-06
140	1	-2.85e-03	0.0	-0.23	0.0	-2.36e-05	0.0
140	2	-1.80e-03	0.0	-0.17	0.0	-1.49e-05	0.0
140	6	-0.01	-7.78e-03	-0.17	3.64e-05	-5.17e-05	1.25e-05
140	8	-0.01	7.78e-03	-0.17	-3.69e-05	-5.16e-05	-1.26e-05
140	28	2.23e-03	-0.02	-0.16	1.22e-04	0.0	1.77e-05
140	38	-5.58e-03	-3.25e-03	-0.16	1.52e-05	-2.88e-05	5.19e-06
140	40	-5.93e-03	3.25e-03	-0.16	-1.55e-05	-2.88e-05	-5.23e-06
140	60	4.46e-05	-9.37e-03	-0.16	5.10e-05	-7.67e-06	7.34e-06
141	1	-2.85e-03	0.0	-0.23	0.0	-2.36e-05	0.0
141	2	-1.80e-03	0.0	-0.17	0.0	-1.49e-05	0.0
141	6	-0.01	-7.07e-03	-0.16	3.66e-05	-5.09e-05	0.0
141	24	-3.89e-03	0.02	-0.17	-1.23e-04	-2.41e-05	0.0
141	28	8.63e-04	-0.02	-0.15	1.23e-04	0.0	0.0
141	38	-5.93e-03	-2.95e-03	-0.16	1.53e-05	-2.85e-05	0.0
141	56	-2.50e-03	8.99e-03	-0.16	-5.14e-05	-1.73e-05	0.0
141	60	-5.24e-04	-8.99e-03	-0.16	5.14e-05	-7.69e-06	0.0
142	1	-2.85e-03	0.0	-0.23	0.0	-2.36e-05	0.0
142	2	-1.80e-03	0.0	-0.17	0.0	-1.49e-05	0.0
142	8	-0.01	7.07e-03	-0.16	-3.66e-05	-5.09e-05	0.0
142	22	-3.89e-03	-0.02	-0.17	1.23e-04	-2.41e-05	0.0
142	34	8.63e-04	0.02	-0.15	-1.23e-04	0.0	0.0
142	40	-5.93e-03	2.95e-03	-0.16	-1.53e-05	-2.85e-05	0.0
142	54	-2.50e-03	-8.99e-03	-0.16	5.14e-05	-1.73e-05	0.0
142	66	-5.24e-04	8.99e-03	-0.16	-5.14e-05	-7.69e-06	0.0
143	1	1.27e-05	7.61e-06	-0.21	1.47e-05	-8.72e-05	0.0
143	2	9.07e-06	5.37e-06	-0.16	1.04e-05	-6.13e-05	0.0

143	18	6.69e-03	-8.67e-05	-0.16	-2.66e-05	-1.87e-05	0.0
143	25	-3.44e-03	8.02e-03	-0.16	-1.18e-04	-7.66e-05	0.0
143	31	-9.08e-05	8.02e-03	-0.17	-1.18e-04	-4.95e-05	0.0
143	50	2.79e-03	-3.16e-05	-0.16	-5.03e-06	-4.53e-05	0.0
143	57	-1.43e-03	3.35e-03	-0.16	-4.33e-05	-6.94e-05	0.0
143	63	-3.29e-05	3.35e-03	-0.16	-4.33e-05	-5.81e-05	0.0
144	1	-1.82e-05	7.73e-06	-0.23	1.08e-05	-1.34e-05	0.0
144	2	-1.31e-05	5.49e-06	-0.17	7.71e-06	-7.62e-06	0.0
144	6	-6.69e-03	-3.58e-03	-0.16	4.51e-05	-4.66e-05	0.0
144	24	1.04e-04	8.09e-03	-0.18	-1.19e-04	-1.83e-05	0.0
144	34	3.45e-03	8.09e-03	-0.17	-1.19e-04	6.71e-06	0.0
144	38	-2.79e-03	-1.49e-03	-0.16	2.33e-05	-2.24e-05	0.0
144	56	3.60e-05	3.38e-03	-0.17	-4.52e-05	-1.06e-05	0.0
144	66	1.43e-03	3.38e-03	-0.17	-4.50e-05	0.0	0.0
145	1	-1.66e-05	7.95e-06	-0.23	9.69e-06	-1.57e-05	0.0
145	2	-1.19e-05	5.63e-06	-0.17	6.89e-06	-9.28e-06	0.0
145	6	-6.69e-03	-3.34e-03	-0.16	4.42e-05	-4.70e-05	0.0
145	24	1.05e-04	7.76e-03	-0.18	-1.19e-04	-2.03e-05	0.0
145	38	-2.79e-03	-1.39e-03	-0.16	2.25e-05	-2.34e-05	0.0
145	56	3.72e-05	3.25e-03	-0.17	-4.59e-05	-1.23e-05	0.0
146	1	1.20e-05	6.75e-06	-0.21	1.33e-05	-8.55e-05	0.0
146	2	8.62e-06	4.71e-06	-0.16	9.40e-06	-6.01e-05	0.0
146	18	6.69e-03	1.23e-04	-0.16	-2.74e-05	-1.86e-05	0.0
146	31	-9.15e-05	7.70e-03	-0.17	-1.18e-04	-4.77e-05	0.0
146	50	2.79e-03	5.56e-05	-0.16	-6.01e-06	-4.46e-05	0.0
146	63	-3.35e-05	3.22e-03	-0.16	-4.39e-05	-5.67e-05	0.0
147	1	7.91e-06	6.29e-06	-0.22	8.18e-06	-7.00e-05	0.0
147	2	5.72e-06	4.34e-06	-0.16	5.62e-06	-4.88e-05	0.0
147	18	6.68e-03	1.00e-03	-0.16	-3.07e-05	-1.11e-05	0.0
147	31	-9.23e-05	6.46e-03	-0.17	-1.18e-04	-3.65e-05	0.0
147	50	2.78e-03	4.21e-04	-0.16	-9.77e-06	-3.42e-05	0.0
147	63	-3.56e-05	2.70e-03	-0.16	-4.62e-05	-4.48e-05	0.0
148	1	0.0	9.38e-06	-0.22	6.20e-06	-3.51e-05	0.0
148	2	0.0	6.58e-06	-0.16	4.27e-06	-2.32e-05	0.0
148	6	-6.67e-03	-1.91e-03	-0.16	4.05e-05	-5.98e-05	0.0
148	24	1.14e-04	5.90e-03	-0.17	-1.18e-04	-3.36e-05	0.0
148	38	-2.78e-03	-7.94e-04	-0.16	1.92e-05	-3.75e-05	0.0
148	56	4.83e-05	2.47e-03	-0.17	-4.72e-05	-2.67e-05	0.0
149	1	1.01e-05	5.40e-06	-0.22	1.03e-05	-7.93e-05	0.0
149	2	7.28e-06	3.69e-06	-0.16	7.17e-06	-5.56e-05	0.0
149	18	6.68e-03	5.55e-04	-0.16	-2.90e-05	-1.68e-05	0.0
149	31	-9.20e-05	7.07e-03	-0.17	-1.18e-04	-4.32e-05	0.0
149	50	2.79e-03	2.35e-04	-0.16	-8.05e-06	-4.11e-05	0.0
149	63	-3.45e-05	2.95e-03	-0.16	-4.54e-05	-5.21e-05	0.0
150	1	-9.16e-06	5.64e-06	-0.23	6.03e-06	-2.28e-05	0.0
150	2	-6.61e-06	3.89e-06	-0.16	4.21e-06	-1.43e-05	0.0
150	6	-6.68e-03	-2.62e-03	-0.16	4.20e-05	-4.95e-05	0.0
150	24	1.09e-04	6.81e-03	-0.17	-1.20e-04	-2.45e-05	0.0
150	38	-2.79e-03	-1.09e-03	-0.16	1.99e-05	-2.75e-05	0.0
150	56	4.22e-05	2.85e-03	-0.17	-4.76e-05	-1.71e-05	0.0
151	1	-1.76e-05	7.93e-06	-0.23	1.03e-05	-1.43e-05	0.0
151	2	-1.27e-05	5.63e-06	-0.17	7.35e-06	-8.32e-06	0.0
151	6	-6.69e-03	-3.46e-03	-0.16	4.46e-05	-4.70e-05	0.0
151	24	1.05e-04	7.93e-03	-0.18	-1.19e-04	-1.92e-05	0.0
151	34	3.45e-03	7.93e-03	-0.17	-1.18e-04	5.68e-06	0.0
151	38	-2.79e-03	-1.44e-03	-0.16	2.29e-05	-2.29e-05	0.0

151	56	3.65e-05	3.31e-03	-0.17	-4.53e-05	-1.13e-05	0.0
151	66	1.43e-03	3.31e-03	-0.17	-4.51e-05	0.0	0.0
152	1	1.24e-05	7.20e-06	-0.21	1.41e-05	-8.65e-05	0.0
152	2	8.91e-06	5.06e-06	-0.16	9.94e-06	-6.08e-05	0.0
152	18	6.69e-03	1.77e-05	-0.16	-2.69e-05	-1.84e-05	0.0
152	31	-9.11e-05	7.86e-03	-0.17	-1.18e-04	-4.87e-05	0.0
152	50	2.79e-03	1.18e-05	-0.16	-5.46e-06	-4.50e-05	0.0
152	63	-3.32e-05	3.28e-03	-0.16	-4.34e-05	-5.75e-05	0.0
153	1	-1.82e-05	-7.73e-06	-0.23	-1.08e-05	-1.34e-05	0.0
153	2	-1.31e-05	-5.49e-06	-0.17	-7.71e-06	-7.62e-06	0.0
153	8	-6.69e-03	3.58e-03	-0.16	-4.51e-05	-4.66e-05	0.0
153	22	1.04e-04	-8.09e-03	-0.18	1.19e-04	-1.83e-05	0.0
153	28	3.45e-03	-8.09e-03	-0.17	1.19e-04	6.71e-06	0.0
153	40	-2.79e-03	1.49e-03	-0.16	-2.33e-05	-2.24e-05	0.0
153	54	3.60e-05	-3.38e-03	-0.17	4.52e-05	-1.06e-05	0.0
153	60	1.43e-03	-3.38e-03	-0.17	4.50e-05	0.0	0.0
154	1	1.27e-05	-7.61e-06	-0.21	-1.47e-05	-8.72e-05	0.0
154	2	9.07e-06	-5.37e-06	-0.16	-1.04e-05	-6.13e-05	0.0
154	12	6.69e-03	8.67e-05	-0.16	2.66e-05	-1.87e-05	0.0
154	19	-3.44e-03	-8.02e-03	-0.16	1.18e-04	-7.66e-05	0.0
154	29	-9.08e-05	-8.02e-03	-0.17	1.18e-04	-4.95e-05	0.0
154	44	2.79e-03	3.16e-05	-0.16	5.03e-06	-4.53e-05	0.0
154	51	-1.43e-03	-3.35e-03	-0.16	4.33e-05	-6.94e-05	0.0
154	61	-3.29e-05	-3.35e-03	-0.16	4.33e-05	-5.81e-05	0.0
155	1	-1.66e-05	-7.95e-06	-0.23	-9.69e-06	-1.57e-05	0.0
155	2	-1.19e-05	-5.63e-06	-0.17	-6.89e-06	-9.28e-06	0.0
155	8	-6.69e-03	3.34e-03	-0.16	-4.42e-05	-4.70e-05	0.0
155	22	1.05e-04	-7.76e-03	-0.18	1.19e-04	-2.03e-05	0.0
155	40	-2.79e-03	1.39e-03	-0.16	-2.25e-05	-2.34e-05	0.0
155	54	3.72e-05	-3.25e-03	-0.17	4.59e-05	-1.23e-05	0.0
156	1	1.20e-05	-6.75e-06	-0.21	-1.33e-05	-8.55e-05	0.0
156	2	8.62e-06	-4.71e-06	-0.16	-9.40e-06	-6.01e-05	0.0
156	12	6.69e-03	-1.23e-04	-0.16	2.74e-05	-1.86e-05	0.0
156	29	-9.15e-05	-7.70e-03	-0.17	1.18e-04	-4.77e-05	0.0
156	44	2.79e-03	-5.56e-05	-0.16	6.01e-06	-4.46e-05	0.0
156	61	-3.35e-05	-3.22e-03	-0.16	4.39e-05	-5.67e-05	0.0
157	1	7.91e-06	-6.29e-06	-0.22	-8.18e-06	-7.00e-05	0.0
157	2	5.72e-06	-4.34e-06	-0.16	-5.62e-06	-4.88e-05	0.0
157	12	6.68e-03	-1.00e-03	-0.16	3.07e-05	-1.11e-05	0.0
157	29	-9.23e-05	-6.46e-03	-0.17	1.18e-04	-3.65e-05	0.0
157	44	2.78e-03	-4.21e-04	-0.16	9.77e-06	-3.42e-05	0.0
157	61	-3.56e-05	-2.70e-03	-0.16	4.62e-05	-4.48e-05	0.0
158	1	0.0	-9.38e-06	-0.22	-6.20e-06	-3.51e-05	0.0
158	2	0.0	-6.58e-06	-0.16	-4.27e-06	-2.32e-05	0.0
158	8	-6.67e-03	1.91e-03	-0.16	-4.05e-05	-5.98e-05	0.0
158	22	1.14e-04	-5.90e-03	-0.17	1.18e-04	-3.36e-05	0.0
158	40	-2.78e-03	7.94e-04	-0.16	-1.92e-05	-3.75e-05	0.0
158	54	4.83e-05	-2.47e-03	-0.17	4.72e-05	-2.67e-05	0.0
159	1	1.01e-05	-5.40e-06	-0.22	-1.03e-05	-7.93e-05	0.0
159	2	7.28e-06	-3.69e-06	-0.16	-7.17e-06	-5.56e-05	0.0
159	12	6.68e-03	-5.55e-04	-0.16	2.90e-05	-1.68e-05	0.0
159	29	-9.20e-05	-7.07e-03	-0.17	1.18e-04	-4.32e-05	0.0
159	44	2.79e-03	-2.35e-04	-0.16	8.05e-06	-4.11e-05	0.0
159	61	-3.45e-05	-2.95e-03	-0.16	4.54e-05	-5.21e-05	0.0
160	1	-9.16e-06	-5.64e-06	-0.23	-6.03e-06	-2.28e-05	0.0
160	2	-6.61e-06	-3.89e-06	-0.16	-4.21e-06	-1.43e-05	0.0

160	8	-6.68e-03	2.62e-03	-0.16	-4.20e-05	-4.95e-05	0.0
160	22	1.09e-04	-6.81e-03	-0.17	1.20e-04	-2.45e-05	0.0
160	40	-2.79e-03	1.09e-03	-0.16	-1.99e-05	-2.75e-05	0.0
160	54	4.22e-05	-2.85e-03	-0.17	4.76e-05	-1.71e-05	0.0
161	1	-1.76e-05	-7.93e-06	-0.23	-1.03e-05	-1.43e-05	0.0
161	2	-1.27e-05	-5.63e-06	-0.17	-7.35e-06	-8.32e-06	0.0
161	8	-6.69e-03	3.46e-03	-0.16	-4.46e-05	-4.70e-05	0.0
161	22	1.05e-04	-7.93e-03	-0.18	1.19e-04	-1.92e-05	0.0
161	28	3.45e-03	-7.93e-03	-0.17	1.18e-04	5.68e-06	0.0
161	40	-2.79e-03	1.44e-03	-0.16	-2.29e-05	-2.29e-05	0.0
161	54	3.65e-05	-3.31e-03	-0.17	4.53e-05	-1.13e-05	0.0
161	60	1.43e-03	-3.31e-03	-0.17	4.51e-05	0.0	0.0
162	1	1.24e-05	-7.20e-06	-0.21	-1.41e-05	-8.65e-05	0.0
162	2	8.91e-06	-5.06e-06	-0.16	-9.94e-06	-6.08e-05	0.0
162	12	6.69e-03	-1.77e-05	-0.16	2.69e-05	-1.84e-05	0.0
162	29	-9.11e-05	-7.86e-03	-0.17	1.18e-04	-4.87e-05	0.0
162	44	2.79e-03	-1.18e-05	-0.16	5.46e-06	-4.50e-05	0.0
162	61	-3.32e-05	-3.28e-03	-0.16	4.34e-05	-5.75e-05	0.0
163	1	-1.56e-05	0.0	-0.23	0.0	-1.58e-05	0.0
163	2	-1.12e-05	0.0	-0.17	0.0	-9.41e-06	0.0
163	3	-5.56e-03	3.47e-04	-0.17	3.66e-05	-4.73e-05	0.0
163	5	-5.56e-03	-2.61e-03	-0.17	3.63e-05	-4.73e-05	0.0
163	28	1.65e-03	-8.49e-03	-0.16	1.22e-04	5.08e-06	0.0
163	35	-2.32e-03	1.43e-04	-0.16	1.53e-05	-2.38e-05	0.0
163	37	-2.32e-03	-1.08e-03	-0.16	1.52e-05	-2.38e-05	0.0
163	60	6.80e-04	-3.54e-03	-0.16	5.09e-05	-1.97e-06	0.0
164	1	1.77e-05	5.41e-06	-0.21	7.84e-06	-8.55e-05	0.0
164	2	1.28e-05	3.84e-06	-0.15	5.57e-06	-6.01e-05	0.0
164	15	5.15e-03	3.86e-03	-0.16	-3.32e-05	-1.86e-05	0.0
164	18	5.98e-03	-3.45e-04	-0.16	-3.25e-05	-1.84e-05	0.0
164	25	-2.33e-03	8.42e-03	-0.15	-1.19e-04	-7.60e-05	0.0
164	47	2.15e-03	1.61e-03	-0.15	-1.04e-05	-4.44e-05	0.0
164	50	2.50e-03	-1.40e-04	-0.15	-1.01e-05	-4.43e-05	0.0
164	57	-9.61e-04	3.52e-03	-0.15	-4.62e-05	-6.83e-05	0.0
165	1	1.77e-05	-5.41e-06	-0.21	-7.84e-06	-8.55e-05	0.0
165	2	1.28e-05	-3.84e-06	-0.15	-5.57e-06	-6.01e-05	0.0
165	12	5.98e-03	3.45e-04	-0.16	3.25e-05	-1.84e-05	0.0
165	13	5.15e-03	-3.86e-03	-0.16	3.32e-05	-1.86e-05	0.0
165	19	-2.33e-03	-8.42e-03	-0.15	1.19e-04	-7.60e-05	0.0
165	44	2.50e-03	1.40e-04	-0.15	1.01e-05	-4.43e-05	0.0
165	45	2.15e-03	-1.61e-03	-0.15	1.04e-05	-4.44e-05	0.0
165	51	-9.61e-04	-3.52e-03	-0.15	4.62e-05	-6.83e-05	0.0
166	1	-1.93e-05	-6.29e-06	-0.23	-8.68e-06	-1.29e-05	0.0
166	2	-1.39e-05	-4.48e-06	-0.17	-6.20e-06	-7.28e-06	0.0
166	8	-6.31e-03	3.89e-03	-0.17	-4.33e-05	-4.63e-05	0.0
166	22	-4.89e-04	-8.49e-03	-0.17	1.20e-04	-1.74e-05	0.0
166	28	2.85e-03	-8.49e-03	-0.17	1.19e-04	7.45e-06	0.0
166	40	-2.64e-03	1.62e-03	-0.16	-2.18e-05	-2.21e-05	0.0
166	54	-2.12e-04	-3.55e-03	-0.17	4.64e-05	-1.01e-05	0.0
166	60	1.18e-03	-3.55e-03	-0.16	4.61e-05	0.0	0.0
167	1	-1.93e-05	6.29e-06	-0.23	8.68e-06	-1.29e-05	0.0
167	2	-1.39e-05	4.48e-06	-0.17	6.20e-06	-7.28e-06	0.0
167	6	-6.31e-03	-3.89e-03	-0.17	4.33e-05	-4.63e-05	0.0
167	24	-4.89e-04	8.49e-03	-0.17	-1.20e-04	-1.74e-05	0.0
167	34	2.85e-03	8.49e-03	-0.17	-1.19e-04	7.45e-06	0.0
167	38	-2.64e-03	-1.62e-03	-0.16	2.18e-05	-2.21e-05	0.0

167	56	-2.12e-04	3.55e-03	-0.17	-4.64e-05	-1.01e-05	0.0
167	66	1.18e-03	3.55e-03	-0.16	-4.61e-05	0.0	0.0
168	1	1.28e-05	8.75e-06	-0.21	1.52e-05	-8.83e-05	0.0
168	2	9.19e-06	6.23e-06	-0.15	1.08e-05	-6.22e-05	0.0
168	18	6.69e-03	-3.42e-04	-0.16	-2.75e-05	-1.88e-05	0.0
168	25	-3.44e-03	8.42e-03	-0.16	-1.18e-04	-7.79e-05	0.0
168	31	-9.05e-05	8.42e-03	-0.16	-1.18e-04	-5.03e-05	0.0
168	50	2.79e-03	-1.37e-04	-0.15	-5.15e-06	-4.58e-05	0.0
168	57	-1.43e-03	3.52e-03	-0.15	-4.29e-05	-7.04e-05	0.0
168	63	-3.27e-05	3.52e-03	-0.16	-4.31e-05	-5.89e-05	0.0
169	1	-1.80e-05	2.76e-06	-0.23	4.03e-06	-1.46e-05	0.0
169	2	-1.30e-05	1.95e-06	-0.17	2.88e-06	-8.56e-06	0.0
169	6	-5.98e-03	-3.89e-03	-0.17	3.92e-05	-4.75e-05	0.0
169	8	-5.15e-03	3.89e-03	-0.17	-3.54e-05	-4.71e-05	0.0
169	34	2.33e-03	8.49e-03	-0.16	-1.20e-04	6.59e-06	0.0
169	38	-2.50e-03	-1.62e-03	-0.16	1.81e-05	-2.33e-05	0.0
169	40	-2.15e-03	1.62e-03	-0.17	-1.30e-05	-2.32e-05	0.0
169	66	9.63e-04	3.55e-03	-0.16	-4.85e-05	0.0	0.0
170	1	1.28e-05	-8.75e-06	-0.21	-1.52e-05	-8.83e-05	0.0
170	2	9.19e-06	-6.23e-06	-0.15	-1.08e-05	-6.22e-05	0.0
170	12	6.69e-03	3.42e-04	-0.16	2.75e-05	-1.88e-05	0.0
170	19	-3.44e-03	-8.42e-03	-0.16	1.18e-04	-7.79e-05	0.0
170	29	-9.05e-05	-8.42e-03	-0.16	1.18e-04	-5.03e-05	0.0
170	44	2.79e-03	1.37e-04	-0.15	5.15e-06	-4.58e-05	0.0
170	51	-1.43e-03	-3.52e-03	-0.15	4.29e-05	-7.04e-05	0.0
170	61	-3.27e-05	-3.52e-03	-0.16	4.31e-05	-5.89e-05	0.0
171	1	-1.80e-05	-2.76e-06	-0.23	-4.03e-06	-1.46e-05	0.0
171	2	-1.30e-05	-1.95e-06	-0.17	-2.88e-06	-8.56e-06	0.0
171	6	-5.15e-03	-3.89e-03	-0.17	3.54e-05	-4.71e-05	0.0
171	8	-5.98e-03	3.89e-03	-0.17	-3.92e-05	-4.75e-05	0.0
171	28	2.33e-03	-8.49e-03	-0.16	1.20e-04	6.59e-06	0.0
171	38	-2.15e-03	-1.62e-03	-0.17	1.30e-05	-2.32e-05	0.0
171	40	-2.50e-03	1.62e-03	-0.16	-1.81e-05	-2.33e-05	0.0
171	60	9.63e-04	-3.55e-03	-0.16	4.85e-05	0.0	0.0
172	1	1.45e-05	-8.62e-06	-0.21	-1.40e-05	-8.78e-05	0.0
172	2	1.04e-05	-6.14e-06	-0.15	-9.91e-06	-6.18e-05	0.0
172	12	6.41e-03	3.42e-04	-0.16	2.82e-05	-1.89e-05	0.0
172	19	-3.01e-03	-8.42e-03	-0.16	1.18e-04	-7.78e-05	0.0
172	29	3.29e-04	-8.42e-03	-0.16	1.18e-04	-5.05e-05	0.0
172	44	2.68e-03	1.38e-04	-0.15	5.89e-06	-4.56e-05	0.0
172	51	-1.25e-03	-3.52e-03	-0.15	4.33e-05	-7.01e-05	0.0
172	61	1.43e-04	-3.52e-03	-0.15	4.35e-05	-5.87e-05	0.0
173	1	1.45e-05	8.62e-06	-0.21	1.40e-05	-8.78e-05	0.0
173	2	1.04e-05	6.14e-06	-0.15	9.91e-06	-6.18e-05	0.0
173	18	6.41e-03	-3.42e-04	-0.16	-2.82e-05	-1.89e-05	0.0
173	25	-3.01e-03	8.42e-03	-0.16	-1.18e-04	-7.78e-05	0.0
173	31	3.29e-04	8.42e-03	-0.16	-1.18e-04	-5.05e-05	0.0
173	50	2.68e-03	-1.38e-04	-0.15	-5.89e-06	-4.56e-05	0.0
173	57	-1.25e-03	3.52e-03	-0.15	-4.33e-05	-7.01e-05	0.0
173	63	1.43e-04	3.52e-03	-0.15	-4.35e-05	-5.87e-05	0.0
174	1	1.62e-05	-7.69e-06	-0.21	-1.17e-05	-8.67e-05	0.0
174	2	1.17e-05	-5.47e-06	-0.15	-8.29e-06	-6.09e-05	0.0
174	12	6.20e-03	3.43e-04	-0.16	3.00e-05	-1.87e-05	0.0
174	13	4.95e-03	-3.86e-03	-0.16	3.11e-05	-1.89e-05	0.0
174	19	-2.67e-03	-8.42e-03	-0.15	1.18e-04	-7.67e-05	0.0
174	44	2.59e-03	1.39e-04	-0.15	7.52e-06	-4.50e-05	0.0

174	45	2.07e-03	-1.61e-03	-0.15	7.98e-06	-4.50e-05	0.0
174	51	-1.10e-03	-3.52e-03	-0.15	4.41e-05	-6.91e-05	0.0
175	1	1.62e-05	7.69e-06	-0.21	1.17e-05	-8.67e-05	0.0
175	2	1.17e-05	5.47e-06	-0.15	8.29e-06	-6.09e-05	0.0
175	15	4.95e-03	3.86e-03	-0.16	-3.11e-05	-1.89e-05	0.0
175	18	6.20e-03	-3.43e-04	-0.16	-3.00e-05	-1.87e-05	0.0
175	25	-2.67e-03	8.42e-03	-0.15	-1.18e-04	-7.67e-05	0.0
175	47	2.07e-03	1.61e-03	-0.15	-7.98e-06	-4.50e-05	0.0
175	50	2.59e-03	-1.39e-04	-0.15	-7.52e-06	-4.50e-05	0.0
175	57	-1.10e-03	3.52e-03	-0.15	-4.41e-05	-6.91e-05	0.0
176	1	1.74e-05	0.0	-0.21	0.0	-8.41e-05	0.0
176	2	1.26e-05	0.0	-0.15	0.0	-5.90e-05	0.0
176	15	5.56e-03	3.85e-03	-0.16	-3.67e-05	-1.85e-05	0.0
176	17	5.56e-03	9.29e-04	-0.16	-3.69e-05	-1.85e-05	0.0
176	19	-1.65e-03	-8.41e-03	-0.15	1.23e-04	-7.47e-05	0.0
176	47	2.32e-03	1.61e-03	-0.15	-1.53e-05	-4.37e-05	0.0
176	49	2.32e-03	3.91e-04	-0.15	-1.54e-05	-4.37e-05	0.0
176	51	-6.78e-04	-3.51e-03	-0.15	5.13e-05	-6.71e-05	0.0
177	1	-1.86e-05	7.34e-06	-0.23	1.12e-05	-1.19e-05	0.0
177	2	-1.34e-05	5.24e-06	-0.17	8.03e-06	-6.59e-06	0.0
177	6	-6.69e-03	-3.89e-03	-0.16	4.56e-05	-4.65e-05	0.0
177	24	1.04e-04	8.49e-03	-0.18	-1.19e-04	-1.74e-05	0.0
177	34	3.45e-03	8.49e-03	-0.17	-1.19e-04	8.09e-06	0.0
177	38	-2.79e-03	-1.62e-03	-0.16	2.37e-05	-2.18e-05	0.0
177	56	3.57e-05	3.55e-03	-0.17	-4.51e-05	-9.64e-06	0.0
177	66	1.43e-03	3.55e-03	-0.17	-4.49e-05	0.0	0.0
178	1	-1.86e-05	-7.34e-06	-0.23	-1.12e-05	-1.19e-05	0.0
178	2	-1.34e-05	-5.24e-06	-0.17	-8.03e-06	-6.59e-06	0.0
178	8	-6.69e-03	3.89e-03	-0.16	-4.56e-05	-4.65e-05	0.0
178	22	1.04e-04	-8.49e-03	-0.18	1.19e-04	-1.74e-05	0.0
178	28	3.45e-03	-8.49e-03	-0.17	1.19e-04	8.09e-06	0.0
178	40	-2.79e-03	1.62e-03	-0.16	-2.37e-05	-2.18e-05	0.0
178	54	3.57e-05	-3.55e-03	-0.17	4.51e-05	-9.64e-06	0.0
178	60	1.43e-03	-3.55e-03	-0.17	4.49e-05	0.0	0.0
179	1	1.53e-05	-8.37e-06	-0.21	-1.31e-05	-8.73e-05	0.0
179	2	1.10e-05	-5.96e-06	-0.15	-9.28e-06	-6.14e-05	0.0
179	12	6.31e-03	3.43e-04	-0.16	2.89e-05	-1.93e-05	0.0
179	19	-2.84e-03	-8.42e-03	-0.16	1.18e-04	-7.71e-05	0.0
179	29	4.98e-04	-8.42e-03	-0.16	1.19e-04	-5.03e-05	0.0
179	44	2.63e-03	1.38e-04	-0.15	6.53e-06	-4.55e-05	0.0
179	51	-1.18e-03	-3.52e-03	-0.15	4.37e-05	-6.95e-05	0.0
179	61	2.14e-04	-3.52e-03	-0.15	4.40e-05	-5.84e-05	0.0
180	1	1.53e-05	8.37e-06	-0.21	1.31e-05	-8.73e-05	0.0
180	2	1.10e-05	5.96e-06	-0.15	9.28e-06	-6.14e-05	0.0
180	18	6.31e-03	-3.43e-04	-0.16	-2.89e-05	-1.93e-05	0.0
180	25	-2.84e-03	8.42e-03	-0.16	-1.18e-04	-7.71e-05	0.0
180	31	4.98e-04	8.42e-03	-0.16	-1.19e-04	-5.03e-05	0.0
180	50	2.63e-03	-1.38e-04	-0.15	-6.53e-06	-4.55e-05	0.0
180	57	-1.18e-03	3.52e-03	-0.15	-4.37e-05	-6.95e-05	0.0
180	63	2.14e-04	3.52e-03	-0.15	-4.40e-05	-5.84e-05	0.0
181	1	-1.91e-05	-6.92e-06	-0.23	-9.73e-06	-1.24e-05	0.0
181	2	-1.38e-05	-4.93e-06	-0.17	-6.96e-06	-6.92e-06	0.0
181	8	-6.42e-03	3.89e-03	-0.17	-4.43e-05	-4.66e-05	0.0
181	22	-3.19e-04	-8.49e-03	-0.17	1.19e-04	-1.72e-05	0.0
181	28	3.02e-03	-8.49e-03	-0.17	1.19e-04	8.05e-06	0.0
181	40	-2.68e-03	1.62e-03	-0.16	-2.26e-05	-2.20e-05	0.0

181	54	-1.41e-04	-3.55e-03	-0.17	4.57e-05	-9.75e-06	0.0
181	60	1.25e-03	-3.55e-03	-0.16	4.55e-05	0.0	0.0
182	1	-1.91e-05	6.92e-06	-0.23	9.73e-06	-1.24e-05	0.0
182	2	-1.38e-05	4.93e-06	-0.17	6.96e-06	-6.92e-06	0.0
182	6	-6.42e-03	-3.89e-03	-0.17	4.43e-05	-4.66e-05	0.0
182	24	-3.19e-04	8.49e-03	-0.17	-1.19e-04	-1.72e-05	0.0
182	34	3.02e-03	8.49e-03	-0.17	-1.19e-04	8.05e-06	0.0
182	38	-2.68e-03	-1.62e-03	-0.16	2.26e-05	-2.20e-05	0.0
182	56	-1.41e-04	3.55e-03	-0.17	-4.57e-05	-9.75e-06	0.0
182	66	1.25e-03	3.55e-03	-0.16	-4.55e-05	0.0	0.0
183	1	-1.93e-05	-5.21e-06	-0.23	-7.20e-06	-1.34e-05	0.0
183	2	-1.39e-05	-3.70e-06	-0.17	-5.15e-06	-7.71e-06	0.0
183	6	-4.94e-03	-3.89e-03	-0.17	3.37e-05	-4.68e-05	0.0
183	8	-6.20e-03	3.89e-03	-0.17	-4.17e-05	-4.69e-05	0.0
183	28	2.68e-03	-8.49e-03	-0.17	1.19e-04	7.11e-06	0.0
183	40	-2.59e-03	1.62e-03	-0.16	-2.05e-05	-2.26e-05	0.0
183	54	-2.82e-04	-3.55e-03	-0.17	4.70e-05	-1.05e-05	0.0
183	60	1.11e-03	-3.55e-03	-0.16	4.67e-05	0.0	0.0
184	1	-1.93e-05	5.21e-06	-0.23	7.20e-06	-1.34e-05	0.0
184	2	-1.39e-05	3.70e-06	-0.17	5.15e-06	-7.71e-06	0.0
184	6	-6.20e-03	-3.89e-03	-0.17	4.17e-05	-4.69e-05	0.0
184	8	-4.94e-03	3.89e-03	-0.17	-3.37e-05	-4.68e-05	0.0
184	34	2.68e-03	8.49e-03	-0.17	-1.19e-04	7.11e-06	0.0
184	38	-2.59e-03	-1.62e-03	-0.16	2.05e-05	-2.26e-05	0.0
184	56	-2.82e-04	3.55e-03	-0.17	-4.70e-05	-1.05e-05	0.0
184	66	1.11e-03	3.55e-03	-0.16	-4.67e-05	0.0	0.0

Nodo	Traslazione X	Traslazione Y	Traslazione Z	Rotazione X	Rotazione Y	Rotazione Z
	-0.16	-0.19	-0.23	-1.32e-03	-1.12e-03	-2.01e-04
	0.02	0.19	-0.14	1.32e-03	1.82e-04	2.01e-04

Nodo	Cmb	Azione X	Azione Y	Azione Z	Azione RX	Azione RY	Azione RZ
		daN	daN	daN	daN cm	daN cm	daN cm

Nodo	Azione X	Azione Y	Azione Z	Azione RX	Azione RY	Azione RZ
-------------	-----------------	-----------------	-----------------	------------------	------------------	------------------

Nodo	Cmb	Azione X	Azione Y	Azione Z	Azione RX	Azione RY	Azione RZ
		daN	daN	daN	daN cm	daN cm	daN cm

RISULTATI ELEMENTI TIPO TRAVE

LEGENDA RISULTATI ELEMENTI TIPO TRAVE

Il controllo dei risultati delle analisi condotte, per quanto concerne gli elementi tipo trave, è possibile in relazione alle tabelle sotto riportate.

Gli elementi vengono suddivisi in relazione alle proprietà in elementi:

- tipo **pilastro**
- tipo **trave in elevazione**
- tipo **trave in fondazione**

Per ogni elemento e per ogni combinazione (o caso di carico) vengono riportati i risultati più significativi.

Per gli elementi tipo *pilastro* sono riportati in tabella i seguenti valori:

Pilas.	numero dell'elemento pilastro
Cmb	combinazione in cui si verificano i valori riportati
M3 mx/mn	momento flettente in campata M3 max (prima riga) / min (seconda riga)
M2 mx/mn	momento flettente in campata M2 max (prima riga) / min (seconda riga)
D2/D3	freccia massima in direzione 2 (prima riga) / direzione 3 (seconda riga)
Q2/Q3	carico totale in direzione 2 (prima riga) / direzione 3 (seconda riga)
Pos.	ascissa del punto iniziale e finale dell'elemento
N, V2, ecc..	sei componenti di sollecitazione al piede ed in sommità dell'elemento

Per gli elementi tipo *trave in elevazione* sono riportati, oltre al numero dell'elemento, i medesimi risultati visti per i pilastri.

Per gli elementi tipo *trave in fondazione* (trave f.) sono riportati, oltre al numero dell'elemento, i medesimi risultati visti per i pilastri e la massima pressione sul terreno.

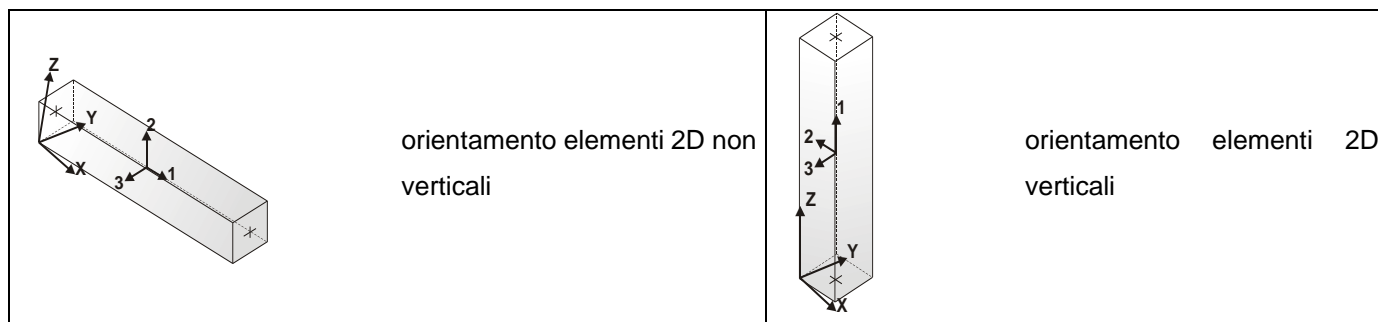

Pilas.	Cmb	M3 mx/mn	M2 mx/mn	D 2 / D 3	Q 2 / Q 3	Pos.	N	V 2	V 3	T	M 2	M 3
		daN cm	daN cm	cm	daN	cm	daN	daN	daN	daN cm	daN cm	daN cm
1	1	0.0	0.03	0.01	0.0	0.0	-199.10	1.74	0.61	-0.09	-122.50	-347.71
		-347.71	-122.50	4.64e-04	0.0	100.0	-184.77	1.74	0.61	-0.09	-61.23	-173.85
						200.0	-170.45	1.74	0.61	-0.09	0.03	0.0
1	2	0.0	0.02	6.92e-03	0.0	0.0	-140.56	1.27	0.43	-0.07	-86.59	-253.02
		-253.02	-86.59	3.28e-04	0.0	100.0	-129.53	1.27	0.43	-0.07	-43.28	-126.51
						200.0	-118.51	1.27	0.43	-0.07	0.02	0.0
1	13	4.88	2950.04	-0.14	0.0	0.0	-91.12	35.59	-14.77	-274.17	2950.04	-7114.16
		-7114.16	-5.01	0.07	0.0	100.0	-80.10	35.59	-14.77	-274.17	1472.52	-3554.64
						200.0	-69.08	35.59	-14.77	-274.17	-5.01	4.88
1	25	2268.30	7.48	0.06	0.0	0.0	-91.70	-11.37	40.04	355.30	-8001.52	2268.30
		-5.86	-8001.52	-0.18	0.0	100.0	-80.67	-11.37	40.04	355.30	-3997.02	1131.22
						200.0	-69.65	-11.37	40.04	355.30	7.48	-5.86
1	31	-5.86	7.47	-0.02	0.0	0.0	-92.64	7.65	40.03	355.35	-7999.90	-1536.34
		-1536.34	-7999.90	-0.18	0.0	100.0	-81.61	7.65	40.03	355.35	-3996.21	-771.10
						200.0	-70.59	7.65	40.03	355.35	7.47	-5.86
1	45	2.03	1178.99	-0.05	0.0	0.0	-90.55	15.63	-5.90	-114.12	1178.99	-3125.05
		-3125.05	-2.07	0.03	0.0	100.0	-79.53	15.63	-5.90	-114.12	588.46	-1561.51
						200.0	-68.51	15.63	-5.90	-114.12	-2.07	2.03
1	57	780.74	3.13	0.03	0.0	0.0	-90.79	-3.92	16.98	147.92	-3393.36	780.74
		-2.44	-3393.36	-0.08	0.0	100.0	-79.76	-3.92	16.98	147.92	-1695.12	389.15
						200.0	-68.74	-3.92	16.98	147.92	3.13	-2.44
1	63	-2.44	3.13	-4.74e-03	0.0	0.0	-91.17	4.00	16.98	147.94	-3392.68	-802.87
		-802.87	-3392.68	-0.08	0.0	100.0	-80.15	4.00	16.98	147.94	-1694.78	-402.66
						200.0	-69.13	4.00	16.98	147.94	3.13	-2.44
2	1	347.71	-0.03	0.01	0.0	0.0	-199.10	-1.74	0.40	7.77e-03	-79.97	347.71
		0.0	-79.97	3.05e-04	0.0	100.0	-184.77	-1.74	0.40	7.77e-03	-40.00	173.85
						200.0	-170.45	-1.74	0.40	7.77e-03	-0.03	0.0
2	2	253.02	-0.02	6.88e-03	0.0	0.0	-140.56	-1.27	0.28	6.36e-03	-57.02	253.02
		0.0	-57.02	2.17e-04	0.0	100.0	-129.53	-1.27	0.28	6.36e-03	-28.52	126.51
						200.0	-118.51	-1.27	0.28	6.36e-03	-0.02	0.0
2	9	7146.35	-5.05	0.15	0.0	0.0	-89.19	-35.75	4.43	274.15	-890.57	7146.35
		-4.87	-890.57	-0.02	0.0	100.0	-78.17	-35.75	4.43	274.15	-447.81	3570.74
						200.0	-67.14	-35.75	4.43	274.15	-5.05	-4.87
2	32	3.72	5.50	-0.04	0.0	0.0	-92.62	10.37	37.69	-240.11	-7532.48	-2069.58
		-2069.58	-7532.48	-0.17	0.0	100.0	-81.60	10.37	37.69	-240.11	-3763.49	-1032.93
						200.0	-70.58	10.37	37.69	-240.11	5.50	3.72
2	34	5.78	7.34	-0.05	0.0	0.0	-92.62	11.36	39.89	-350.59	-7971.44	-2266.73
		-2266.73	-7971.44	-0.18	0.0	100.0	-81.60	11.36	39.89	-350.59	-3982.05	-1130.47
						200.0	-70.57	11.36	39.89	-350.59	7.34	5.78
2	41	3138.43	-2.11	0.07	0.0	0.0	-89.76	-15.70	2.03	114.08	-406.98	3138.43
		-2.03	-406.98	-0.01	0.0	100.0	-78.74	-15.70	2.03	114.08	-204.55	1568.20
						200.0	-67.72	-15.70	2.03	114.08	-2.11	-2.03
2	64	1.55	2.28	-0.01	0.0	0.0	-91.16	3.50	15.91	-100.05	-3180.80	-697.85
		-697.85	-3180.80	-0.07	0.0	100.0	-80.14	3.50	15.91	-100.05	-1589.26	-348.15
						200.0	-69.12	3.50	15.91	-100.05	2.28	1.55
2	66	2.41	3.05	-0.02	0.0	0.0	-91.16	3.91	16.83	-145.99	-3363.14	-780.06
		-780.06	-3363.14	-0.08	0.0	100.0	-80.14	3.91	16.83	-145.99	-1680.05	-388.83
						200.0	-69.12	3.91	16.83	-145.99	3.05	2.41
3	1	347.71	79.97	0.01	0.0	0.0	-199.10	-1.74	-0.40	-7.77e-03	79.97	347.71
		0.0	0.03	-3.05e-04	0.0	100.0	-184.77	-1.74	-0.40	-7.77e-03	40.00	173.85
						200.0	-170.45	-1.74	-0.40	-7.77e-03	0.03	0.0
3	2	253.02	57.02	6.88e-03	0.0	0.0	-140.56	-1.27	-0.28	-6.36e-03	57.02	253.02

		0.0	0.02	-2.17e-04	0.0	100.0	-129.53	-1.27	-0.28	-6.36e-03	28.52	126.51
						200.0	-118.51	-1.27	-0.28	-6.36e-03	0.02	0.0
3	3	7146.35	890.57	0.15	0.0	0.0	-91.12	-35.75	-4.43	-274.15	890.57	7146.35
		-4.87	5.05	0.02	0.0	100.0	-80.10	-35.75	-4.43	-274.15	447.81	3570.74
						200.0	-69.08	-35.75	-4.43	-274.15	5.05	-4.87
3	28	5.78	7971.44	-0.05	0.0	0.0	-91.68	11.36	-39.89	350.59	7971.44	-2266.73
		-2266.73	-7.34	0.18	0.0	100.0	-80.66	11.36	-39.89	350.59	3982.05	-1130.47
						200.0	-69.64	11.36	-39.89	350.59	-7.34	5.78
3	30	3.72	7532.48	-0.04	0.0	0.0	-92.62	10.37	-37.69	240.11	7532.48	-2069.58
		-2069.58	-5.50	0.17	0.0	100.0	-81.60	10.37	-37.69	240.11	3763.49	-1032.93
						200.0	-70.58	10.37	-37.69	240.11	-5.50	3.72
3	35	3138.43	406.98	0.07	0.0	0.0	-90.55	-15.70	-2.03	-114.08	406.98	3138.43
		-2.03	2.11	0.01	0.0	100.0	-79.53	-15.70	-2.03	-114.08	204.55	1568.20
						200.0	-68.51	-15.70	-2.03	-114.08	2.11	-2.03
3	60	2.41	3363.14	-0.02	0.0	0.0	-90.78	3.91	-16.83	145.99	3363.14	-780.06
		-780.06	-3.05	0.08	0.0	100.0	-79.76	3.91	-16.83	145.99	1680.05	-388.83
						200.0	-68.74	3.91	-16.83	145.99	-3.05	2.41
3	62	1.55	3180.80	-0.01	0.0	0.0	-91.16	3.50	-15.91	100.05	3180.80	-697.85
		-697.85	-2.28	0.07	0.0	100.0	-80.14	3.50	-15.91	100.05	1589.26	-348.15
						200.0	-69.12	3.50	-15.91	100.05	-2.28	1.55
4	1	0.0	122.50	0.01	0.0	0.0	-199.10	1.74	-0.61	0.09	122.50	-347.71
		-347.71	-0.03	-4.64e-04	0.0	100.0	-184.77	1.74	-0.61	0.09	61.23	-173.85
						200.0	-170.45	1.74	-0.61	0.09	-0.03	0.0
4	2	0.0	86.59	6.92e-03	0.0	0.0	-140.56	1.27	-0.43	0.07	86.59	-253.02
		-253.02	-0.02	-3.28e-04	0.0	100.0	-129.53	1.27	-0.43	0.07	43.28	-126.51
						200.0	-118.51	1.27	-0.43	0.07	-0.02	0.0
4	15	4.88	5.01	-0.14	0.0	0.0	-92.32	35.59	14.77	274.17	-2950.04	-7114.16
		-7114.16	-2950.04	-0.07	0.0	100.0	-81.30	35.59	14.77	274.17	-1472.52	-3554.64
						200.0	-70.28	35.59	14.77	274.17	5.01	4.88
4	19	2268.30	8001.52	0.06	0.0	0.0	-87.68	-11.37	-40.04	-355.30	8001.52	2268.30
		-5.86	-7.48	0.18	0.0	100.0	-76.65	-11.37	-40.04	-355.30	3997.02	1131.22
						200.0	-65.63	-11.37	-40.04	-355.30	-7.48	-5.86
4	33	3.81	5.59	-0.04	0.0	0.0	-92.64	13.18	36.96	244.97	-7387.73	-2631.78
		-2631.78	-7387.73	-0.18	0.0	100.0	-81.61	13.18	36.96	244.97	-3691.07	-1313.99
						200.0	-70.59	13.18	36.96	244.97	5.59	3.81
4	47	2.03	2.07	-0.05	0.0	0.0	-91.04	15.63	5.90	114.12	-1178.99	-3125.05
		-3125.05	-1178.99	-0.03	0.0	100.0	-80.02	15.63	5.90	114.12	-588.46	-1561.51
						200.0	-69.00	15.63	5.90	114.12	2.07	2.03
4	51	780.74	3393.36	0.03	0.0	0.0	-89.14	-3.92	-16.98	-147.92	3393.36	780.74
		-2.44	-3.13	0.08	0.0	100.0	-78.12	-3.92	-16.98	-147.92	1695.12	389.15
						200.0	-67.10	-3.92	-16.98	-147.92	-3.13	-2.44
4	65	1.59	2.32	-0.01	0.0	0.0	-91.17	6.30	15.18	102.13	-3034.85	-1259.11
		-1259.11	-3034.85	-0.07	0.0	100.0	-80.15	6.30	15.18	102.13	-1516.26	-628.76
						200.0	-69.13	6.30	15.18	102.13	2.32	1.59
Pilas.		M3 mx/mn	M2 mx/mn	D 2 / D 3	Q 2 / Q 3		N	V 2	V 3	T		
		-7114.16	-8001.52	-0.18	0.0		-199.10	-35.75	-40.04	-355.30		
		7146.35	8001.52	0.18	0.0		-65.63	35.59	40.04	355.35		
Trave	Cmb	M3 mx/mn	M2 mx/mn	D 2 / D 3	Q 2 / Q 3	Pos.	N	V 2	V 3	T	M 2	M 3
		daN cm	daN cm	cm	daN	cm	daN	daN	daN	daN cm	daN cm	daN cm
5	1	1.165e+04	0.01	-0.14	-310.60	0.0	-1.74	155.30	-1.73e-04	-0.03	0.01	0.0
		0.0	-0.04	0.0	0.0	150.0	-1.74	1.44e-06	-1.73e-04	-0.03	-0.02	1.165e+04
						300.0	-1.74	-155.30	-1.73e-04	-0.03	-0.04	0.0
5	2	8014.72	7.63e-03	-0.10	-213.73	0.0	-1.27	106.86	-1.27e-04	-0.02	7.63e-03	0.0

		0.0	-0.03	0.0	0.0	150.0	-1.27	0.0	-1.27e-04	-0.02	-0.01	8014.72
						300.0	-1.27	-106.86	-1.27e-04	-0.02	-0.03	0.0
5	3	4234.72	16.33	-0.04	-112.93	0.0	-1.50	56.46	0.11	5.00	-16.35	0.0
		0.0	-16.35	0.05	0.0	150.0	-1.50	0.0	0.11	5.00	-0.01	4234.72
						300.0	-1.50	-56.46	0.11	5.00	16.33	0.0
5	5	4234.72	203.22	-0.04	-112.93	0.0	-1.50	56.46	-1.35	-1.13	203.22	0.0
		0.0	-203.24	-0.02	0.0	150.0	-1.50	0.0	-1.35	-1.13	-0.01	4234.72
						300.0	-1.50	-56.46	-1.35	-1.13	-203.24	0.0
5	11	4234.73	203.16	-0.05	-112.93	0.0	-1.32	56.46	-1.35	-1.12	203.16	0.0
		0.0	-203.18	-0.02	0.0	150.0	-1.32	0.0	-1.35	-1.12	-0.01	4234.73
						300.0	-1.32	-56.46	-1.35	-1.12	-203.18	0.0
5	21	4234.73	344.27	-0.05	-112.93	0.0	-1.46	56.46	-2.30	5.59	344.27	0.0
		0.0	-344.28	0.04	0.0	150.0	-1.46	0.0	-2.30	5.59	-4.72e-03	4234.73
						300.0	-1.46	-56.46	-2.30	5.59	-344.28	0.0
5	35	4234.72	6.37	-0.05	-112.93	0.0	-1.44	56.46	0.04	2.07	-6.40	0.0
		0.0	-6.40	0.02	0.0	150.0	-1.44	0.0	0.04	2.07	-0.01	4234.72
						300.0	-1.44	-56.46	0.04	2.07	6.37	0.0
5	37	4234.72	84.34	-0.05	-112.93	0.0	-1.44	56.46	-0.56	-0.48	84.34	0.0
		0.0	-84.36	-6.45e-03	0.0	150.0	-1.44	0.0	-0.56	-0.48	-0.01	4234.72
						300.0	-1.44	-56.46	-0.56	-0.48	-84.36	0.0
5	43	4234.73	84.31	-0.05	-112.93	0.0	-1.37	56.46	-0.56	-0.48	84.31	0.0
		0.0	-84.34	-6.45e-03	0.0	150.0	-1.37	0.0	-0.56	-0.48	-0.01	4234.73
						300.0	-1.37	-56.46	-0.56	-0.48	-84.34	0.0
5	53	4234.73	143.46	-0.05	-112.93	0.0	-1.43	56.46	-0.96	2.32	143.46	0.0
		0.0	-143.48	0.02	0.0	150.0	-1.43	0.0	-0.96	2.32	-9.96e-03	4234.73
						300.0	-1.43	-56.46	-0.96	2.32	-143.48	0.0
6	1	530.05	0.02	-1.47e-03	-30.29	0.0	-0.40	15.14	0.0	0.0	0.02	0.0
		0.0	0.02	0.0	0.0	70.0	-0.40	0.0	0.0	0.0	0.02	530.05
						140.0	-0.40	-15.14	0.0	0.0	0.02	0.0
6	2	407.73	0.01	-1.13e-03	-23.30	0.0	-0.29	11.65	0.0	0.0	0.01	0.0
		0.0	0.01	0.0	0.0	70.0	-0.29	0.0	0.0	0.0	0.01	407.73
						140.0	-0.29	-11.65	0.0	0.0	0.01	0.0
6	7	407.73	221.35	-5.17e-03	-23.30	0.0	-0.27	11.65	-3.16	1.99	221.35	0.0
		0.0	-221.40	6.87e-03	0.0	70.0	-0.27	0.0	-3.16	1.99	-0.02	407.73
						140.0	-0.27	-11.65	-3.16	1.99	-221.40	0.0
6	11	407.73	221.43	5.17e-03	-23.30	0.0	-0.32	11.65	3.16	-1.99	-221.32	0.0
		0.0	-221.32	-6.87e-03	0.0	70.0	-0.32	0.0	3.16	-1.99	0.06	407.73
						140.0	-0.32	-11.65	3.16	-1.99	221.43	0.0
6	16	407.73	220.78	-5.16e-03	-23.30	0.0	-0.32	11.65	3.15	-2.01	-220.66	0.0
		0.0	-220.66	-6.96e-03	0.0	70.0	-0.32	0.0	3.15	-2.01	0.06	407.73
						140.0	-0.32	-11.65	3.15	-2.01	220.78	0.0
6	17	407.73	221.43	-5.17e-03	-23.30	0.0	-0.32	11.65	-3.16	1.99	221.43	0.0
		0.0	-221.32	6.87e-03	0.0	70.0	-0.32	0.0	-3.16	1.99	0.06	407.73
						140.0	-0.32	-11.65	-3.16	1.99	-221.32	0.0
6	19	407.73	17.21	0.02	-23.30	0.0	-0.28	11.65	-0.25	5.83	17.21	0.0
		0.0	-17.20	0.03	0.0	70.0	-0.28	0.0	-0.25	5.83	4.83e-03	407.73
						140.0	-0.28	-11.65	-0.25	5.83	-17.20	0.0
6	35	407.73	80.87	2.14e-03	-23.30	0.0	-0.28	11.65	-1.16	2.03	80.87	0.0
		0.0	-80.87	8.79e-03	0.0	70.0	-0.28	0.0	-1.16	2.03	-3.93e-05	407.73
						140.0	-0.28	-11.65	-1.16	2.03	-80.87	0.0
6	39	407.73	92.09	-2.43e-03	-23.30	0.0	-0.28	11.65	-1.32	0.83	92.09	0.0
		0.0	-92.09	2.87e-03	0.0	70.0	-0.28	0.0	-1.32	0.83	-3.93e-05	407.73
						140.0	-0.28	-11.65	-1.32	0.83	-92.09	0.0
6	43	407.73	92.13	2.16e-03	-23.30	0.0	-0.30	11.65	1.32	-0.83	-92.06	0.0
		0.0	-92.06	-2.87e-03	0.0	70.0	-0.30	0.0	1.32	-0.83	0.03	407.73
						140.0	-0.30	-11.65	1.32	-0.83	92.13	0.0

6	49	407.73	92.13	-2.43e-03	-23.30	0.0	-0.30	11.65	-1.32	0.83	92.13	0.0
		0.0	-92.06	2.87e-03	0.0	70.0	-0.30	0.0	-1.32	0.83	0.03	407.73
						140.0	-0.30	-11.65	-1.32	0.83	-92.06	0.0
7	1	530.05	-0.05	-1.47e-03	-30.29	0.0	-0.61	15.14	0.0	0.0	-0.05	0.0
		0.0	-0.05	0.0	0.0	70.0	-0.61	0.0	0.0	0.0	-0.05	530.05
						140.0	-0.61	-15.14	0.0	0.0	-0.05	0.0
7	2	407.73	-0.04	-1.13e-03	-23.30	0.0	-0.43	11.65	0.0	0.0	-0.04	0.0
		0.0	-0.04	0.0	0.0	70.0	-0.43	0.0	0.0	0.0	-0.04	407.73
						140.0	-0.43	-11.65	0.0	0.0	-0.04	0.0
7	3	407.73	194.16	5.26e-03	-23.30	0.0	-0.46	11.65	-2.77	4.88	194.16	0.0
		0.0	-194.33	0.02	0.0	70.0	-0.46	0.0	-2.77	4.88	-0.09	407.73
						140.0	-0.46	-11.65	-2.77	4.88	-194.33	0.0
7	7	407.73	221.33	-5.21e-03	-23.30	0.0	-0.46	11.65	-3.16	1.98	221.33	0.0
		0.0	-221.50	6.87e-03	0.0	70.0	-0.46	0.0	-3.16	1.98	-0.09	407.73
						140.0	-0.46	-11.65	-3.16	1.98	-221.50	0.0
7	22	407.73	19.45	0.02	-23.30	0.0	-0.45	11.65	0.28	-5.75	-19.56	0.0
		0.0	-19.56	-0.03	0.0	70.0	-0.45	0.0	0.28	-5.75	-0.05	407.73
						140.0	-0.45	-11.65	0.28	-5.75	19.45	0.0
7	26	407.73	105.13	-0.02	-23.30	0.0	-0.45	11.65	1.50	3.70	-105.24	0.0
		0.0	-105.24	0.02	0.0	70.0	-0.45	0.0	1.50	3.70	-0.05	407.73
						140.0	-0.45	-11.65	1.50	3.70	105.13	0.0
7	35	407.73	80.79	2.20e-03	-23.30	0.0	-0.45	11.65	-1.15	2.03	80.79	0.0
		0.0	-80.91	8.79e-03	0.0	70.0	-0.45	0.0	-1.15	2.03	-0.06	407.73
						140.0	-0.45	-11.65	-1.15	2.03	-80.91	0.0
7	39	407.73	92.05	-2.44e-03	-23.30	0.0	-0.45	11.65	-1.32	0.82	92.05	0.0
		0.0	-92.17	2.87e-03	0.0	70.0	-0.45	0.0	-1.32	0.82	-0.06	407.73
						140.0	-0.45	-11.65	-1.32	0.82	-92.17	0.0
7	42	407.73	91.75	-2.44e-03	-23.30	0.0	-0.45	11.65	1.31	-0.84	-91.87	0.0
		0.0	-91.87	-2.91e-03	0.0	70.0	-0.45	0.0	1.31	-0.84	-0.06	407.73
						140.0	-0.45	-11.65	1.31	-0.84	91.75	0.0
7	54	407.73	8.14	7.22e-03	-23.30	0.0	-0.45	11.65	0.12	-2.40	-8.24	0.0
		0.0	-8.24	-0.01	0.0	70.0	-0.45	0.0	0.12	-2.40	-0.05	407.73
						140.0	-0.45	-11.65	0.12	-2.40	8.14	0.0
8	1	1.165e+04	0.04	-0.14	-310.60	0.0	-1.74	155.30	1.73e-04	0.03	-0.01	0.0
		0.0	-0.01	0.0	0.0	150.0	-1.74	1.44e-06	1.73e-04	0.03	0.02	1.165e+04
						300.0	-1.74	-155.30	1.73e-04	0.03	0.04	0.0
8	2	8014.72	0.03	-0.10	-213.73	0.0	-1.27	106.86	1.27e-04	0.02	-7.63e-03	0.0
		0.0	-7.63e-03	0.0	0.0	150.0	-1.27	0.0	1.27e-04	0.02	0.01	8014.72
						300.0	-1.27	-106.86	1.27e-04	0.02	0.03	0.0
8	3	4234.72	16.47	-0.04	-112.93	0.0	-1.48	56.46	0.11	5.05	-16.43	0.0
		0.0	-16.43	0.05	0.0	150.0	-1.48	0.0	0.11	5.05	0.02	4234.72
						300.0	-1.48	-56.46	0.11	5.05	16.47	0.0
8	7	4234.72	203.24	-0.04	-112.93	0.0	-1.50	56.46	1.35	1.13	-203.22	0.0
		0.0	-203.22	0.02	0.0	150.0	-1.50	0.0	1.35	1.13	0.01	4234.72
						300.0	-1.50	-56.46	1.35	1.13	203.24	0.0
8	23	4234.72	344.28	-0.05	-112.93	0.0	-1.46	56.46	2.30	-5.59	-344.27	0.0
		0.0	-344.27	-0.04	0.0	150.0	-1.46	0.0	2.30	-5.59	4.72e-03	4234.72
						300.0	-1.46	-56.46	2.30	-5.59	344.28	0.0
8	35	4234.72	6.47	-0.05	-112.93	0.0	-1.43	56.46	0.04	2.11	-6.44	0.0
		0.0	-6.44	0.02	0.0	150.0	-1.43	0.0	0.04	2.11	0.02	4234.72
						300.0	-1.43	-56.46	0.04	2.11	6.47	0.0
8	39	4234.72	84.36	-0.05	-112.93	0.0	-1.44	56.46	0.56	0.48	-84.34	0.0
		0.0	-84.34	6.45e-03	0.0	150.0	-1.44	0.0	0.56	0.48	0.01	4234.72
						300.0	-1.44	-56.46	0.56	0.48	84.36	0.0
8	55	4234.72	143.48	-0.05	-112.93	0.0	-1.43	56.46	0.96	-2.32	-143.46	0.0
		0.0	-143.46	-0.02	0.0	150.0	-1.43	0.0	0.96	-2.32	9.96e-03	4234.72

300.0 -1.43 -56.46 0.96 -2.32 143.48 0.0

Trave	M3 mx/mn	M2 mx/mn	D 2 / D 3	Q 2 / Q 3	N	V 2	V 3	T
	0.0	-344.28	-0.14	-310.60	-1.74	-155.30	-3.16	-5.75
	1.165e+04	344.28	0.05	0.0	-0.27	155.30	3.16	5.83

RISULTATI ELEMENTI TIPO SHELL

LEGENDA RISULTATI ELEMENTI TIPO SHELL

Il controllo dei risultati delle analisi condotte, per quanto concerne gli elementi tipo shell, è possibile in relazione alle tabelle sottoriportate.

Per ogni elemento, e per ogni combinazione (o caso di carico) vengono riportati i risultati più significativi.

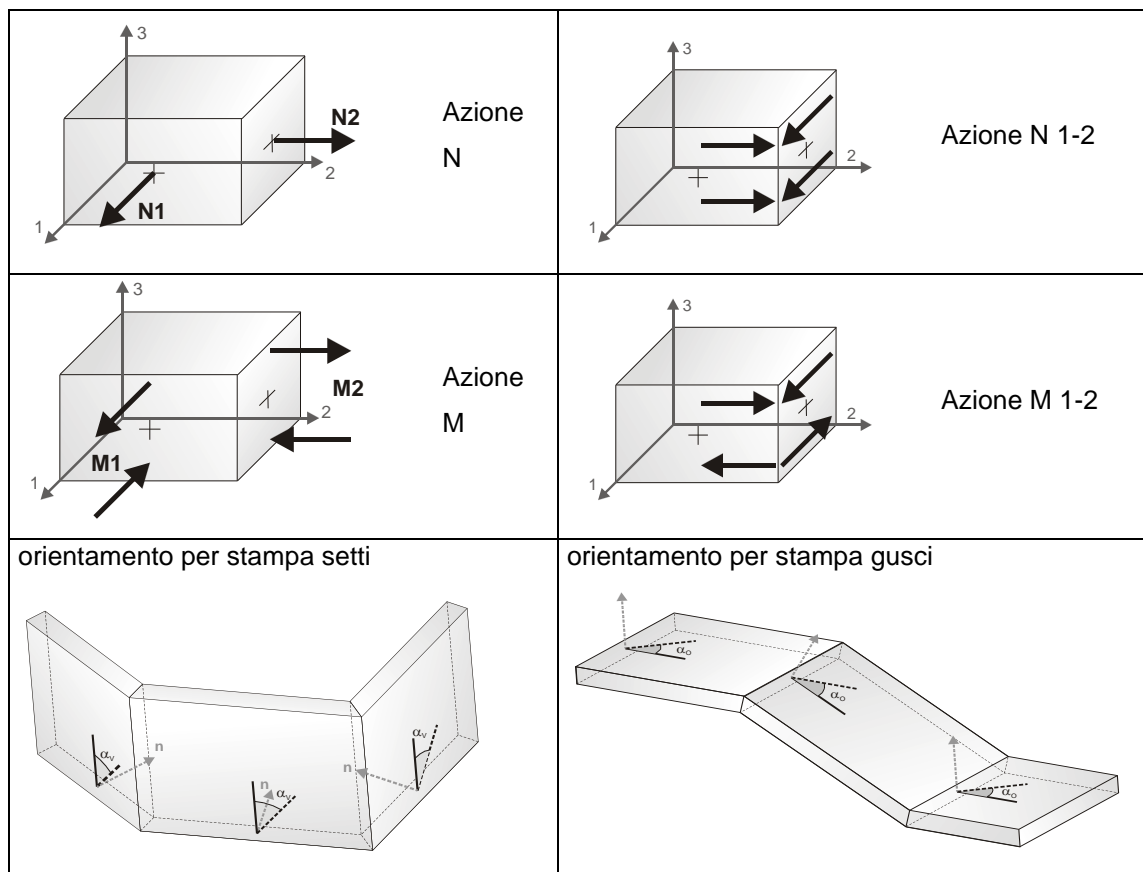

In particolare vengono riportati in ogni nodo di un elemento per ogni combinazione:

tensione di Von Mises		(valore riassuntivo del complessivo stato di sollecitazione)
N max		sforzo membranale principale massimo
N min		sforzo membranale principale minimo
M max		sforzo flessionale principale massimo
M min		sforzo flessionale principale minimo
N1	N2	sforzi membranali e flessionali in direzione locale 1 e 2 dell'elemento
N1-2	M1	(lo sforzo 2-1 è uguale allo sforzo 1-2 per la reciprocità delle tensioni
M2	M1-2	tangenziali)

I suddetti risultati possono a scelta del progettista essere preceduti o sostituiti da valori di sollecitazione non più riferiti al sistema locale dell'elemento ma al sistema globale.

In questo caso gli elementi vengono raggruppati in gruppi (M_S: macro gusci o macro setti, raggruppati per materiale, spessore, e posizione fisica) per la valutazione dei valori mediati ai nodi appartenenti agli elementi dei gruppi stessi.

I valori di sollecitazione sono, in questo caso, riferiti ad una terna specifica del gruppo ruotata di α_o attorno all'asse Z per i gusci e ruotata di α_v attorno alla normale (che per definizione è orizzontale) al piano del setto.

Per i setti, in particolare, se α_V è zero, l'asse '1-1 rappresenta la verticale e l'asse '2-2 l'orizzontale contenuta nel setto. Le azioni sui setti possono essere espresse anche con formato macro, cioè riferite all'intero macroelemento.

In particolare vengono riportati per ogni quota Z dei nodi e per ogni combinazione i seguenti valori:

N memb.	Azione membranale complessiva agente sulla parete in direzione Z
V memb.	Azione complessiva di taglio agente nel piano del macroelemento
V orto	Azione complessiva di taglio agente in direzione perpendicolare al macroelemento
M memb.	Azione flessionale complessiva agente nel piano del macroelemento
M orto	Azione flessionale complessiva agente in direzione perpendicolare al macroelemento
T	Azione torsionale complessiva agente nel piano orizzontale

Elem.	Cmb	Nodo	Von Mises	N max	N min	N 1	N 2	N 1-2	M max	M min	M 1	M 2	M 1-2
			daN/cm ²	daN/cm	daN/cm	daN/cm	daN/cm	daN/cm	daN	daN	daN	daN	daN
1	1	55	1.34	0.74	-0.08	0.47	0.18	-0.39	-87.55	-160.77	-135.03	-113.29	-34.96
		48	0.46	0.09	-0.21	0.09	-0.21	0.02	-30.47	-53.99	-30.63	-53.82	-1.96
		3	0.46	0.35	-0.16	0.09	0.10	-0.25	-29.37	-54.59	-42.62	-41.34	-12.60
		44	0.36	0.01	-0.18	-0.11	-0.06	0.09	-21.86	-43.15	-41.05	-23.96	-6.35
1	2	55	0.96	0.53	-0.06	0.34	0.13	-0.27	-61.14	-115.46	-96.46	-80.14	-25.90
		48	0.32	0.07	-0.15	0.07	-0.15	0.02	-21.68	-38.22	-21.92	-37.98	-1.99
		3	0.33	0.25	-0.11	0.06	0.07	-0.18	-20.01	-39.42	-30.28	-29.15	-9.69
		44	0.26	8.24e-03	-0.13	-0.08	-0.04	0.07	-15.04	-30.89	-29.00	-16.93	-5.14
1	31	55	4.95	0.44	-0.24	0.26	-0.05	-0.30	-75.62	-547.43	-213.85	-409.20	-214.73
		48	2.71	-0.03	-0.36	-0.03	-0.36	4.82e-03	125.54	-197.75	-71.32	-0.88	-157.76
		3	0.37	0.13	-0.29	-0.04	-0.12	-0.20	30.86	-11.16	-1.97	21.67	-17.37
		44	3.14	-0.15	-0.29	-0.20	-0.24	0.06	-64.92	-354.20	-72.74	-346.38	-46.91
1	63	55	2.52	0.51	-0.14	0.32	0.06	-0.30	-60.81	-286.36	-138.43	-208.75	-107.15
		48	1.18	0.03	-0.24	0.03	-0.24	0.01	38.41	-99.08	-42.22	-18.45	-67.71
		3	0.29	0.21	-0.19	0.02	-6.78e-03	-0.20	5.44	-26.17	-15.83	-4.90	-14.83
		44	1.38	-0.06	-0.20	-0.13	-0.13	0.07	-38.38	-158.40	-43.12	-153.67	-23.36
2	1	93	1.12	1.08	-1.56	-1.14	0.66	-0.97	-78.16	-131.97	-85.50	-124.63	-18.46
		82	0.91	1.17	-0.56	-0.40	1.00	-0.51	-35.70	-104.37	-40.15	-99.92	-16.91
		12	0.74	0.80	-0.50	0.04	0.26	-0.64	-41.70	-87.38	-47.25	-81.83	-14.92
		57	0.81	1.45	-0.70	0.85	-0.09	-0.97	-72.33	-92.48	-82.72	-82.08	-10.07
2	2	93	0.79	0.77	-1.11	-0.81	0.47	-0.69	-55.44	-93.80	-61.09	-88.15	-13.59
		82	0.65	0.83	-0.40	-0.29	0.71	-0.36	-25.44	-74.28	-28.85	-70.88	-12.45
		12	0.53	0.57	-0.36	0.03	0.18	-0.46	-29.28	-62.33	-33.69	-57.92	-11.24
		57	0.58	1.03	-0.50	0.60	-0.07	-0.69	-50.60	-66.42	-58.96	-58.06	-7.90
2	19	93	1.68	0.78	-1.47	-0.91	0.21	-0.98	-81.23	-199.45	-89.33	-191.35	-29.87
		82	1.24	0.66	-0.77	-0.38	0.27	-0.64	-42.88	-144.53	-48.88	-138.53	-23.96
		12	1.00	0.74	-1.11	-0.06	-0.30	-0.92	-30.23	-114.95	-30.48	-114.70	4.52
		57	1.27	1.37	-1.14	0.59	-0.36	-1.16	-60.30	-149.47	-60.34	-149.44	1.85
2	61	93	1.13	0.73	-1.22	-0.89	0.40	-0.74	-64.12	-135.47	-68.05	-131.54	-16.28
		82	0.92	0.74	-0.49	-0.33	0.58	-0.41	-29.81	-105.20	-31.78	-103.22	-12.05
		12	0.71	0.55	-0.62	-0.06	-7.25e-03	-0.58	-22.01	-81.88	-22.01	-81.88	-0.32
		57	0.78	1.09	-0.71	0.57	-0.19	-0.81	-47.72	-92.03	-47.76	-92.00	-1.27

3	1	66	1.31	0.53	-1.15	-0.36	-0.26	0.84	-81.24	-153.11	-100.04	-134.31	31.59
		50	1.08	0.83	0.29	0.83	0.29	0.03	-82.98	-124.78	-101.82	-105.94	20.80
		6	0.85	0.61	-0.01	0.37	0.22	0.30	-28.17	-98.69	-82.28	-44.59	29.80
		42	0.86	1.02	5.02e-03	1.00	0.02	-0.13	-35.75	-97.21	-95.81	-37.16	9.18
3	2	66	0.93	0.38	-0.83	-0.26	-0.19	0.60	-56.67	-109.11	-70.45	-95.32	23.08
		50	0.77	0.59	0.20	0.59	0.20	0.02	-58.94	-89.04	-72.57	-75.41	14.98
		6	0.61	0.43	-0.01	0.26	0.16	0.22	-19.71	-70.56	-58.61	-31.66	21.56
		42	0.61	0.73	2.56e-03	0.72	0.01	-0.09	-25.41	-69.47	-68.41	-26.47	6.76
3	18	66	4.72	0.23	-1.06	-0.49	-0.34	0.64	-151.04	-547.58	-429.17	-269.45	-181.48
		50	3.77	0.41	0.04	0.41	0.04	-6.16e-03	-110.38	-434.12	-423.83	-120.67	-56.79
		6	0.56	0.16	-0.18	-7.20e-03	-0.01	0.17	-4.82	-60.72	-59.73	-5.81	7.40
		42	2.72	0.51	-0.17	0.49	-0.14	-0.12	22.54	-270.28	-96.84	-150.89	-143.90
3	45	66	1.68	0.35	-0.96	-0.39	-0.22	0.65	-87.80	-200.69	-195.36	-93.12	-23.94
		50	1.90	0.53	0.15	0.52	0.15	0.03	-96.51	-225.26	-221.54	-100.22	21.54
		6	0.63	0.39	-0.07	0.20	0.12	0.23	-15.80	-71.74	-61.13	-26.41	21.94
		42	1.01	0.71	-0.03	0.69	-0.01	-0.11	16.12	-95.09	-67.27	-11.70	-48.16
4	1	95	0.92	1.56	-0.22	-0.05	1.39	-0.52	-47.61	-107.44	-92.20	-62.85	26.07
		94	1.12	1.55	-1.33	-1.10	1.32	-0.79	-53.43	-128.16	-128.05	-53.55	-2.91
		13	2.22	2.00	-2.97	-2.12	1.16	1.87	-107.50	-251.97	-230.10	-129.37	51.78
		68	1.19	0.72	-1.95	-1.59	0.37	0.90	-93.09	-134.96	-106.55	-121.51	19.55
4	2	95	0.66	1.11	-0.16	-0.03	0.99	-0.37	-33.83	-76.41	-65.38	-44.86	18.66
		94	0.79	1.11	-0.95	-0.78	0.94	-0.57	-37.94	-90.46	-90.37	-38.03	-2.17
		13	1.58	1.42	-2.12	-1.52	0.82	1.33	-76.20	-179.34	-163.69	-91.85	37.00
		68	0.84	0.51	-1.39	-1.14	0.27	0.64	-65.94	-96.18	-75.70	-86.42	14.14
4	28	95	1.22	1.01	-0.08	-0.02	0.96	-0.25	-74.80	-142.93	-86.45	-131.28	25.66
		94	0.86	1.48	-0.84	-0.69	1.33	-0.57	-64.35	-100.20	-99.57	-64.98	4.70
		13	2.27	1.76	-3.00	-2.25	1.01	1.73	-49.78	-243.41	-173.81	-119.38	92.91
		68	1.84	0.60	-2.41	-1.89	0.08	1.14	-50.74	-207.03	-87.87	-169.90	66.51
4	60	95	0.88	1.10	-0.13	-0.02	1.00	-0.34	-55.79	-101.52	-74.67	-82.65	22.51
		94	0.81	1.31	-0.91	-0.74	1.14	-0.59	-50.10	-94.85	-94.82	-50.12	1.10
		13	1.88	1.57	-2.58	-1.91	0.91	1.53	-67.46	-208.71	-171.18	-104.99	62.39
		68	1.23	0.55	-1.86	-1.50	0.20	0.86	-57.61	-142.45	-78.33	-121.73	36.45
5	1	59	1.14	0.32	-0.50	0.01	-0.19	0.40	-89.56	-133.72	-132.76	-90.52	6.46
		46	0.62	0.62	0.27	0.28	0.61	-0.05	-24.60	-70.95	-30.69	-64.86	15.66
		10	0.74	0.80	-0.38	0.08	0.34	0.57	-47.97	-88.88	-52.81	-84.04	13.21
		58	0.73	0.88	-0.02	0.86	-2.20e-03	0.13	-48.97	-85.72	-63.57	-71.11	17.98
5	2	59	0.81	0.23	-0.36	9.33e-03	-0.14	0.28	-63.28	-95.64	-94.86	-64.05	4.95
		46	0.44	0.44	0.19	0.20	0.44	-0.03	-17.06	-50.65	-21.96	-45.76	11.85
		10	0.53	0.57	-0.27	0.06	0.24	0.41	-33.92	-63.40	-37.74	-59.58	9.90
		58	0.52	0.62	-0.02	0.61	-2.25e-03	0.09	-33.89	-61.56	-45.08	-50.37	13.58
5	31	59	5.19	0.04	-0.67	-0.11	-0.52	0.29	-121.86	-590.97	-258.09	-454.74	-212.95
		46	2.73	0.23	0.05	0.10	0.18	-0.08	56.21	-251.66	-125.15	-70.30	-151.47
		10	0.58	0.35	-0.52	-0.12	-0.05	0.43	-1.10	-60.47	-1.65	-59.92	-5.66
		58	3.94	0.47	-0.41	0.45	-0.39	0.13	-73.95	-439.91	-81.79	-432.06	-53.01
5	57	59	1.87	0.18	-0.50	2.53e-03	-0.32	0.30	-70.74	-220.56	-89.55	-201.75	-49.65
		46	0.90	0.40	0.21	0.22	0.39	-0.05	32.88	-72.61	1.05	-40.78	-48.43
		10	0.53	0.58	-0.36	0.05	0.18	0.46	-27.82	-62.96	-29.85	-60.93	8.19
		58	1.84	0.64	-0.20	0.62	-0.18	0.13	-62.48	-213.18	-65.80	-209.85	22.13
6	1	69	1.22	1.58	-1.33	0.16	0.09	-1.45	-107.51	-136.09	-111.27	-132.33	9.66
		60	1.00	0.99	-1.38	0.95	-1.33	0.32	-76.57	-115.08	-82.22	-109.42	-13.63
		14	2.38	1.43	-4.00	-1.32	-1.25	-2.71	-158.19	-269.66	-213.67	-214.18	-55.73
		70	1.07	1.10	-1.63	-1.56	1.04	0.41	-73.70	-123.62	-120.10	-77.22	-12.78
6	2	69	0.86	1.13	-0.96	0.11	0.06	-1.04	-75.86	-96.45	-78.44	-93.87	6.82
		60	0.71	0.70	-0.99	0.67	-0.95	0.23	-54.32	-82.21	-58.61	-77.92	-10.06
		14	1.69	1.01	-2.86	-0.95	-0.90	-1.93	-112.16	-191.81	-151.84	-152.13	-39.82
		70	0.77	0.79	-1.16	-1.12	0.74	0.30	-52.34	-88.36	-85.68	-55.02	-9.44

6	34	69	5.29	1.05	-1.28	-0.05	-0.18	-1.17	-97.11	-586.85	-209.52	-474.44	-205.95
		60	3.54	0.50	-1.66	0.50	-1.66	-6.01e-03	60.61	-333.42	-134.00	-138.81	-197.00
		14	2.60	0.71	-4.28	-1.84	-1.73	-2.49	-87.16	-285.70	-167.23	-205.63	-97.40
		70	4.03	0.46	-1.90	-1.89	0.45	0.13	-130.92	-466.36	-158.76	-438.52	-92.54
6	66	69	2.50	1.14	-1.16	0.03	-0.05	-1.15	-83.06	-286.72	-124.40	-245.38	-81.92
		60	1.75	0.64	-1.31	0.63	-1.30	0.14	-7.57	-185.44	-91.52	-101.49	-88.80
		14	2.09	0.90	-3.60	-1.40	-1.30	-2.25	-101.86	-234.64	-160.29	-176.22	-65.91
		70	1.97	0.67	-1.52	-1.49	0.65	0.24	-97.86	-233.17	-114.78	-216.25	-44.75
7	1	51	0.66	0.96	-0.14	0.95	-0.13	0.11	-38.36	-76.73	-65.93	-49.16	-17.25
		49	0.79	0.73	-0.05	0.58	0.10	-0.31	-42.47	-95.15	-70.45	-67.17	-26.29
		8	0.74	0.71	0.13	0.71	0.13	0.03	-18.46	-82.61	-63.41	-37.67	-29.38
		26	0.66	0.68	-0.14	0.67	-0.13	-0.11	-23.15	-75.55	-69.23	-29.48	-17.07
7	2	51	0.48	0.69	-0.10	0.68	-0.09	0.08	-27.17	-55.56	-47.84	-34.89	-12.63
		49	0.57	0.52	-0.04	0.41	0.07	-0.22	-29.19	-68.35	-50.05	-47.49	-19.54
		8	0.54	0.51	0.09	0.51	0.09	0.02	-12.32	-59.44	-45.11	-26.64	-21.68
		26	0.48	0.49	-0.10	0.48	-0.09	-0.08	-16.48	-55.03	-50.43	-21.08	-12.50
7	5	51	1.04	0.65	0.01	0.62	0.04	0.13	-38.38	-120.22	-107.08	-51.52	-30.05
		49	0.89	0.56	-0.30	0.28	-0.02	-0.40	-37.17	-105.08	-99.01	-43.24	-19.37
		8	0.78	0.34	-0.10	0.26	-0.02	-0.17	-17.00	-87.66	-82.42	-22.24	-18.52
		26	0.97	0.29	3.77e-03	0.28	0.02	-0.06	-24.15	-110.32	-99.52	-34.95	-28.53
7	37	51	0.75	0.71	-0.05	0.69	-0.04	0.10	-32.14	-86.30	-76.14	-42.29	-21.14
		49	0.68	0.55	-0.14	0.37	0.04	-0.31	-31.00	-80.54	-69.34	-42.20	-20.72
		8	0.62	0.44	0.04	0.43	0.05	-0.05	-13.14	-68.54	-59.28	-22.41	-20.67
		26	0.73	0.43	-0.06	0.42	-0.05	-0.07	-19.51	-82.21	-74.74	-26.98	-20.32
8	1	97	0.61	2.05	0.44	1.77	0.73	0.61	-35.43	-70.20	-35.52	-70.11	1.77
		96	1.85	2.02	-2.61	1.43	-2.02	-1.54	-101.06	-210.23	-112.51	-198.78	-33.45
		15	0.84	0.62	-0.43	0.54	-0.35	-0.28	-53.48	-100.50	-88.88	-65.09	-20.28
		31	0.85	1.10	-8.67e-03	1.09	-2.53e-03	-0.08	-48.13	-101.39	-60.83	-88.69	-22.69
8	2	97	0.41	1.46	0.32	1.27	0.51	0.42	-25.00	-47.17	-25.05	-47.12	1.11
		96	1.31	1.44	-1.85	1.01	-1.42	-1.11	-71.11	-148.63	-79.64	-140.09	-24.26
		15	0.60	0.44	-0.30	0.38	-0.25	-0.20	-37.01	-72.03	-63.19	-45.84	-15.21
		31	0.61	0.79	-5.58e-03	0.78	-3.24e-04	-0.06	-34.13	-72.25	-43.81	-62.57	-16.59
8	19	97	0.53	1.51	0.43	1.46	0.48	0.24	-30.63	-60.22	-32.79	-58.06	-7.70
		96	2.03	1.59	-2.44	1.04	-1.90	-1.38	-84.59	-228.83	-99.11	-214.31	-43.40
		15	1.27	0.59	-0.84	0.40	-0.66	-0.48	-53.97	-146.90	-89.97	-110.90	-45.27
		31	0.95	0.99	-0.17	0.90	-0.08	-0.31	-34.88	-110.82	-65.87	-79.83	-37.32
8	51	97	0.45	1.53	0.41	1.42	0.52	0.34	-28.53	-50.10	-29.08	-49.55	-3.40
		96	1.65	1.54	-2.17	1.04	-1.67	-1.26	-77.46	-187.27	-89.35	-175.38	-34.12
		15	0.87	0.52	-0.54	0.41	-0.43	-0.32	-42.43	-102.41	-74.04	-70.80	-29.94
		31	0.76	0.90	-0.06	0.87	-0.03	-0.17	-35.23	-90.83	-55.95	-70.11	-26.88
9	1	62	0.67	1.01	0.15	1.00	0.16	-0.09	-37.96	-77.36	-65.72	-49.60	17.97
		61	0.78	0.57	-0.44	0.48	-0.35	0.29	-43.71	-92.90	-70.53	-66.07	24.50
		16	0.90	1.06	-0.64	0.80	-0.38	0.62	-64.80	-105.90	-84.31	-86.39	20.52
		32	0.75	1.12	-3.89e-03	1.09	0.03	-0.18	-46.28	-87.84	-59.79	-74.32	19.47
9	2	62	0.49	0.73	0.11	0.72	0.12	-0.06	-26.89	-56.00	-47.68	-35.21	13.15
		61	0.56	0.41	-0.31	0.35	-0.25	0.20	-30.08	-66.74	-50.11	-46.72	18.25
		16	0.64	0.76	-0.46	0.57	-0.27	0.44	-45.01	-75.82	-59.87	-60.96	15.40
		32	0.54	0.80	3.28e-04	0.78	0.02	-0.12	-32.76	-62.65	-43.11	-52.30	14.22
9	8	62	0.97	0.67	0.28	0.66	0.30	-0.08	-47.12	-113.80	-109.37	-51.55	16.61
		61	1.16	0.41	-0.71	0.17	-0.48	0.46	-12.38	-124.72	-99.92	-37.18	46.59
		16	1.14	0.89	-0.80	0.56	-0.47	0.68	-21.50	-125.79	-95.82	-51.47	47.20
		32	0.88	0.92	0.18	0.88	0.23	-0.18	-51.08	-102.15	-88.41	-64.81	22.65
9	39	62	0.72	0.74	0.19	0.73	0.20	-0.07	-35.86	-83.79	-76.61	-43.04	17.10
		61	0.79	0.41	-0.48	0.29	-0.36	0.29	-19.94	-89.55	-69.36	-40.13	31.59
		16	0.84	0.82	-0.62	0.58	-0.37	0.54	-32.99	-97.72	-74.45	-56.26	31.06
		32	0.71	0.88	0.08	0.86	0.11	-0.15	-40.91	-82.01	-64.77	-58.15	20.28

10	1	53	2.00	1.09	-0.85	0.27	-0.03	-0.96	-86.31	-237.30	-236.53	-87.08	-10.75
		52	1.33	0.75	-0.19	0.29	0.27	0.47	-37.45	-152.12	-151.49	-38.08	-8.49
		21	1.42	0.42	0.05	0.31	0.15	0.16	-26.60	-158.45	-157.76	-27.29	-9.54
		23	1.93	1.06	-0.37	0.76	-0.07	-0.59	-40.11	-215.02	-214.90	-40.23	-4.56
10	2	53	1.46	0.78	-0.60	0.20	-0.02	-0.68	-61.16	-172.70	-172.18	-61.68	-7.55
		52	0.98	0.53	-0.13	0.21	0.19	0.32	-26.98	-111.90	-111.54	-27.34	-5.51
		21	1.05	0.29	0.04	0.23	0.11	0.11	-19.19	-116.48	-116.06	-19.61	-6.38
		23	1.41	0.77	-0.26	0.55	-0.05	-0.42	-28.37	-156.68	-156.61	-28.45	-3.12
10	19	53	1.72	0.95	-0.41	0.49	0.05	-0.64	-61.43	-200.61	-199.62	-62.43	-11.71
		52	1.21	0.72	0.09	0.50	0.31	0.30	-32.23	-136.73	-135.45	-33.50	-11.47
		21	1.29	0.53	0.21	0.51	0.23	0.08	-24.38	-143.09	-141.67	-25.79	-12.88
		23	1.68	1.00	-0.12	0.86	0.02	-0.37	-27.85	-184.03	-183.69	-28.19	-7.29
10	51	53	1.68	0.88	-0.53	0.35	6.55e-03	-0.68	-62.10	-196.27	-195.57	-62.80	-9.61
		52	1.16	0.61	-0.02	0.35	0.24	0.31	-30.08	-131.37	-130.84	-30.60	-7.30
		21	1.24	0.40	0.13	0.36	0.16	0.09	-22.12	-137.04	-136.39	-22.76	-8.56
		23	1.63	0.90	-0.20	0.72	-0.02	-0.40	-28.34	-179.15	-178.98	-28.51	-5.05
11	1	99	2.01	2.19	-1.22	-1.21	2.17	-0.26	-52.89	-222.39	-218.91	-56.37	-24.04
		98	1.86	1.06	-1.75	-0.35	-0.34	1.41	-159.02	-213.15	-212.67	-159.51	5.08
		19	1.13	1.96	-0.78	1.48	-0.29	1.05	-44.79	-126.12	-124.79	-46.12	-10.32
		17	2.52	1.85	-2.41	-1.90	1.34	-1.39	-129.84	-292.27	-288.34	-133.77	-24.97
11	2	99	1.46	1.54	-0.90	-0.88	1.53	-0.17	-38.89	-162.35	-160.06	-41.18	-16.66
		98	1.35	0.76	-1.23	-0.24	-0.24	0.99	-112.17	-155.47	-155.12	-112.53	3.90
		19	0.83	1.41	-0.54	1.07	-0.20	0.74	-31.96	-92.90	-92.11	-32.74	-6.86
		17	1.83	1.31	-1.73	-1.36	0.94	-0.99	-92.60	-212.37	-209.77	-95.20	-17.45
11	3	99	1.77	1.58	-0.90	-0.89	1.57	-0.15	-44.41	-196.37	-193.32	-47.47	-21.32
		98	1.56	0.89	-1.41	-0.18	-0.34	1.15	-111.54	-184.24	-183.48	-112.30	7.40
		19	1.02	1.69	-0.67	1.32	-0.30	0.86	-28.69	-111.63	-111.53	-28.79	-2.91
		17	2.12	1.41	-1.74	-1.31	0.98	-1.08	-96.91	-244.93	-241.58	-100.26	-22.02
11	35	99	1.70	1.56	-0.95	-0.95	1.55	-0.14	-44.14	-189.03	-186.64	-46.53	-18.46
		98	1.51	0.84	-1.33	-0.22	-0.27	1.09	-113.61	-177.93	-177.41	-114.14	5.80
		19	0.98	1.59	-0.59	1.24	-0.24	0.80	-30.88	-108.38	-108.08	-31.18	-4.78
		17	2.08	1.36	-1.82	-1.41	0.96	-1.06	-97.26	-240.24	-237.54	-99.96	-19.47
12	1	64	1.99	1.18	-0.81	0.43	-0.05	0.97	-85.34	-234.69	-234.20	-85.83	8.58
		63	1.34	0.69	-0.25	0.16	0.27	-0.47	-38.49	-153.60	-152.75	-39.34	9.84
		20	1.20	1.86	-0.73	0.75	0.39	-1.28	-31.84	-135.03	-134.87	-31.99	-4.02
		18	2.49	1.36	-2.29	-1.09	0.16	1.71	-148.83	-291.32	-279.57	-160.58	39.19
12	2	64	1.45	0.85	-0.57	0.32	-0.04	0.69	-60.46	-170.82	-170.49	-60.78	5.99
		63	0.98	0.48	-0.17	0.12	0.19	-0.32	-27.74	-112.96	-112.46	-28.24	6.49
		20	0.88	1.32	-0.51	0.53	0.27	-0.90	-22.83	-99.70	-99.54	-22.99	-3.52
		18	1.80	0.97	-1.63	-0.77	0.11	1.22	-105.89	-211.24	-203.24	-113.88	27.90
12	25	64	1.72	1.03	-0.37	0.62	0.04	0.64	-58.02	-198.61	-197.71	-58.92	11.19
		63	1.21	0.63	0.10	0.40	0.33	-0.26	-32.60	-137.63	-136.35	-33.88	11.54
		20	1.09	1.56	-0.26	0.88	0.42	-0.88	-27.95	-121.48	-121.47	-27.95	0.51
		18	2.06	1.10	-1.43	-0.54	0.21	1.21	-105.56	-242.49	-233.34	-114.71	34.19
12	57	64	1.67	0.95	-0.49	0.47	-0.01	0.68	-60.24	-194.21	-193.69	-60.77	8.40
		63	1.16	0.54	-0.04	0.25	0.25	-0.29	-30.71	-132.43	-131.81	-31.33	7.94
		20	1.05	1.46	-0.42	0.71	0.34	-0.92	-25.36	-117.30	-117.21	-25.46	-2.92
		18	2.03	1.05	-1.60	-0.70	0.15	1.26	-108.37	-237.78	-229.57	-116.57	31.53
13	1	54	0.43	2.09	0.08	1.73	0.44	0.78	22.29	-20.72	18.36	-16.79	12.39
		53	1.66	1.83	-0.92	1.65	-0.74	-0.68	-69.16	-192.50	-178.97	-82.69	-38.54
		23	1.63	1.34	-0.41	1.32	-0.39	-0.16	-31.50	-177.74	-171.47	-37.77	-29.64
		28	0.28	1.54	0.23	1.48	0.30	0.28	6.24	-22.18	4.78	-20.72	6.27
13	2	54	0.31	1.51	0.05	1.25	0.31	0.56	17.00	-13.48	13.92	-10.40	9.19
		53	1.20	1.32	-0.66	1.19	-0.53	-0.49	-48.70	-139.05	-129.70	-58.05	-27.52
		23	1.18	0.97	-0.29	0.96	-0.28	-0.11	-22.14	-128.94	-124.56	-26.52	-21.18
		28	0.20	1.11	0.17	1.06	0.21	0.20	5.23	-15.27	4.01	-14.06	4.85

13	19	54	0.35	1.72	0.05	1.50	0.26	0.56	17.41	-17.90	9.10	-9.59	14.98
		53	1.41	1.55	-0.58	1.45	-0.48	-0.46	-47.98	-160.03	-150.82	-57.18	-30.77
		23	1.42	1.23	-0.22	1.23	-0.22	-0.04	-21.26	-152.36	-147.89	-25.73	-23.81
		28	0.25	1.37	0.15	1.34	0.17	0.17	1.99	-22.65	-4.29	-16.37	10.74
13	51	54	0.33	1.69	0.04	1.43	0.29	0.59	19.41	-13.22	13.81	-7.62	12.31
		53	1.36	1.50	-0.64	1.37	-0.52	-0.51	-48.10	-155.75	-146.43	-57.42	-30.28
		23	1.36	1.13	-0.26	1.13	-0.26	-0.09	-21.44	-146.90	-142.39	-25.95	-23.35
		28	0.22	1.28	0.16	1.24	0.20	0.20	4.85	-17.50	1.54	-14.20	7.93
14	1	100	0.38	1.99	0.79	1.91	0.88	-0.31	7.67	-32.66	6.48	-31.47	-6.83
		99	1.41	4.04	1.65	3.34	2.35	1.08	-50.88	-156.93	-144.26	-63.55	34.39
		17	1.31	5.26	2.03	4.42	2.87	-1.42	-68.32	-141.65	-138.37	-71.60	-15.15
		29	0.33	1.74	0.15	1.54	0.35	0.53	33.65	13.50	21.62	25.53	9.88
14	2	100	0.27	1.43	0.54	1.36	0.60	-0.23	5.25	-23.66	4.36	-22.78	-4.98
		99	1.02	2.91	1.18	2.42	1.67	0.78	-35.83	-114.06	-104.61	-45.28	25.49
		17	0.95	3.80	1.43	3.19	2.04	-1.04	-47.88	-102.25	-100.13	-50.00	-10.52
		29	0.25	1.24	0.09	1.10	0.23	0.37	26.32	10.97	16.25	21.04	7.29
14	29	100	0.30	1.78	0.50	1.71	0.57	-0.29	4.67	-25.05	3.02	-23.40	-6.81
		99	1.20	3.32	1.38	2.96	1.74	0.75	-36.11	-131.69	-120.42	-47.38	30.82
		17	1.06	4.35	1.45	3.68	2.13	-1.22	-46.37	-112.44	-111.19	-47.63	-9.01
		29	0.30	1.47	0.05	1.37	0.15	0.36	32.88	15.48	19.21	29.15	7.14
14	61	100	0.30	1.64	0.51	1.57	0.59	-0.28	6.30	-24.33	4.88	-22.92	-6.43
		99	1.17	3.23	1.30	2.80	1.73	0.80	-37.10	-129.33	-118.64	-47.80	29.53
		17	1.05	4.24	1.46	3.58	2.12	-1.18	-46.73	-112.44	-110.77	-48.40	-10.34
		29	0.31	1.39	0.07	1.28	0.18	0.36	33.40	15.47	19.54	29.33	7.51
15	1	65	0.45	2.09	1.77e-03	1.84	0.25	-0.68	23.88	-20.97	20.48	-17.57	-11.87
		64	1.68	1.64	-0.78	1.48	-0.62	0.60	-68.88	-195.47	-182.42	-81.93	38.49
		18	1.72	3.34	-1.75	2.77	-1.18	1.61	-116.25	-203.36	-166.05	-153.57	43.11
		30	0.59	2.96	-0.71	1.86	0.39	-1.68	43.81	-6.16	23.22	14.43	-24.59
15	2	65	0.32	1.51	-3.70e-03	1.33	0.18	-0.50	18.13	-13.63	15.47	-10.97	-8.80
		64	1.22	1.19	-0.56	1.07	-0.44	0.43	-48.49	-141.22	-132.21	-57.50	27.46
		18	1.22	2.42	-1.25	2.00	-0.84	1.16	-82.52	-145.22	-119.91	-107.83	30.76
		30	0.43	2.14	-0.52	1.35	0.28	-1.22	33.42	-2.67	17.48	13.26	-17.92
15	9	65	0.44	1.57	-0.09	1.40	0.08	-0.50	15.00	-30.58	5.65	-21.23	-18.40
		64	1.44	1.20	-0.44	1.13	-0.37	0.32	-47.33	-164.02	-156.71	-54.64	28.27
		18	1.34	2.49	-1.19	2.11	-0.80	1.13	-85.21	-159.30	-139.30	-105.22	32.89
		30	0.56	2.16	-0.68	1.34	0.14	-1.29	36.68	-17.57	10.94	8.17	-27.09
15	41	65	0.37	1.63	-0.05	1.45	0.13	-0.53	19.08	-18.52	13.40	-12.84	-13.47
		64	1.39	1.26	-0.52	1.16	-0.42	0.41	-47.73	-158.81	-150.51	-56.02	29.20
		18	1.32	2.61	-1.27	2.18	-0.84	1.22	-84.47	-156.78	-134.66	-106.59	33.32
		30	0.51	2.27	-0.64	1.43	0.20	-1.32	39.40	-6.06	17.07	16.27	-22.73
16	1	50	1.16	1.26	-0.41	0.95	-0.10	0.65	-70.21	-138.37	-100.79	-107.78	33.90
		54	0.19	1.59	-0.08	1.51	-2.27e-03	-0.35	-4.44	-19.79	-5.76	-18.47	4.30
		28	0.25	1.27	-0.05	1.27	-0.05	-0.02	-4.13	-27.00	-12.37	-18.76	10.98
		6	0.98	1.14	-0.03	1.12	-0.01	0.15	-32.65	-111.73	-91.82	-52.56	34.32
16	2	50	0.83	0.89	-0.29	0.67	-0.07	0.46	-49.55	-98.38	-71.41	-76.52	24.28
		54	0.12	1.14	-0.05	1.09	3.13e-03	-0.24	-2.88	-13.09	-4.10	-11.87	3.32
		28	0.18	0.91	-0.03	0.91	-0.03	-0.01	-2.43	-19.18	-8.84	-12.76	8.14
		6	0.70	0.81	-0.02	0.80	-0.01	0.10	-22.82	-79.53	-65.10	-37.25	24.70
16	28	50	1.13	1.15	-0.27	0.83	0.05	0.59	-65.72	-134.28	-87.92	-112.08	32.08
		54	0.38	1.28	-0.07	1.28	-0.06	-0.08	5.76	-34.66	-14.50	-14.40	20.21
		28	0.50	1.17	-0.10	1.15	-0.08	0.13	12.36	-43.84	-15.79	-15.69	28.10
		6	0.92	1.10	0.08	1.05	0.13	0.23	-40.88	-108.19	-76.96	-72.11	33.57
16	60	50	0.95	1.02	-0.29	0.75	-0.02	0.53	-55.35	-113.15	-78.60	-89.91	28.34
		54	0.24	1.25	-0.05	1.22	-0.02	-0.17	0.76	-21.93	-9.16	-12.02	11.26
		28	0.33	1.06	-0.06	1.06	-0.06	0.06	4.47	-31.05	-12.85	-13.73	17.75
		6	0.78	0.96	0.02	0.93	0.05	0.15	-29.90	-90.07	-69.79	-50.17	28.44

17	1	94	0.68	2.85	1.01	2.03	1.84	-0.92	-36.55	-75.79	-65.40	-46.94	-17.32
		100	0.32	2.11	0.97	2.07	1.01	-0.21	-8.18	-34.63	-10.33	-32.48	-7.22
		29	0.19	2.40	-0.58	1.42	0.39	-1.40	2.67	-7.95	-0.56	-4.71	-4.89
		13	0.86	3.37	1.95	2.57	2.75	0.71	-65.65	-88.48	-75.76	-78.37	11.34
17	2	94	0.48	2.04	0.70	1.44	1.31	-0.66	-25.18	-53.48	-45.63	-33.02	-12.67
		100	0.23	1.51	0.67	1.48	0.70	-0.16	-6.43	-25.30	-8.20	-23.52	-5.51
		29	0.14	1.72	-0.45	1.02	0.26	-1.02	2.85	-4.43	-0.32	-1.26	-3.61
		13	0.61	2.38	1.39	1.82	1.96	0.49	-46.56	-62.71	-53.52	-55.76	8.00
17	28	94	0.61	2.45	0.89	1.64	1.69	-0.78	-49.09	-63.19	-53.06	-59.22	-6.34
		100	0.26	1.66	0.77	1.64	0.79	-0.11	-9.69	-28.38	-11.88	-26.19	-6.01
		29	0.14	1.96	-0.40	1.23	0.33	-1.09	-0.33	-8.04	-8.03	-0.34	-0.27
		13	0.87	2.61	1.77	2.02	2.36	0.38	-54.47	-96.05	-66.75	-83.77	18.97
17	60	94	0.52	2.29	0.76	1.55	1.50	-0.77	-36.36	-56.93	-48.81	-44.48	-10.06
		100	0.25	1.65	0.71	1.63	0.74	-0.15	-7.80	-26.86	-10.17	-24.49	-6.29
		29	0.12	1.92	-0.47	1.17	0.28	-1.11	2.74	-4.35	-3.53	1.92	-2.27
		13	0.73	2.48	1.62	1.93	2.17	0.41	-49.83	-78.29	-59.65	-68.47	13.53
18	1	60	1.14	0.88	-1.42	0.73	-1.27	-0.56	-70.46	-133.86	-102.60	-101.72	-31.70
		65	0.24	1.65	0.64	1.58	0.71	0.25	-3.59	-24.13	-5.45	-22.27	-5.89
		30	0.31	2.07	0.51	1.51	1.07	0.74	17.33	-12.21	0.61	4.51	14.64
		14	1.81	1.72	-2.32	1.27	-1.87	-1.26	-91.85	-206.65	-103.43	-195.06	-34.58
18	2	60	0.81	0.62	-1.02	0.52	-0.91	-0.40	-49.77	-95.14	-72.70	-72.21	-22.68
		65	0.16	1.18	0.47	1.13	0.51	0.18	-2.26	-16.20	-3.89	-14.57	-4.48
		30	0.22	1.48	0.39	1.09	0.77	0.52	13.85	-7.70	0.54	5.61	10.47
		14	1.29	1.21	-1.66	0.89	-1.34	-0.90	-64.97	-146.96	-73.18	-138.75	-24.61
18	34	60	1.28	0.66	-1.70	0.52	-1.56	-0.55	-65.52	-147.79	-91.70	-121.62	-38.32
		65	0.36	1.36	0.67	1.36	0.67	0.01	0.61	-34.79	-14.49	-19.69	-17.51
		30	0.13	1.58	0.69	1.32	0.95	0.41	6.03	-7.93	-7.48	5.58	2.46
		14	1.84	1.22	-2.37	0.86	-2.02	-1.07	-79.36	-208.33	-92.26	-195.43	-38.70
18	66	60	1.00	0.65	-1.34	0.52	-1.22	-0.47	-55.63	-116.49	-80.96	-91.17	-30.00
		65	0.25	1.30	0.59	1.28	0.60	0.10	-1.10	-23.88	-9.04	-15.94	-10.86
		30	0.19	1.57	0.57	1.25	0.89	0.47	12.72	-6.21	-2.71	9.22	7.35
		14	1.55	1.23	-2.02	0.88	-1.67	-1.00	-71.20	-176.02	-82.17	-165.05	-32.08
19	1	52	1.25	0.99	-0.22	0.97	-0.20	0.16	-42.79	-142.17	-142.16	-42.80	-1.03
		51	0.63	0.88	0.05	0.83	0.10	-0.20	-47.98	-72.26	-64.94	-55.30	-11.14
		26	0.65	0.73	0.06	0.73	0.06	-0.02	-28.50	-75.06	-70.88	-32.68	-13.32
		21	1.18	0.70	-0.07	0.70	-0.07	0.01	-20.02	-128.29	-127.82	-20.49	-7.09
19	2	52	0.92	0.71	-0.15	0.70	-0.14	0.11	-30.56	-104.38	-104.38	-30.56	-0.26
		51	0.45	0.63	0.03	0.60	0.07	-0.14	-34.01	-52.19	-46.97	-39.23	-8.23
		26	0.48	0.52	0.04	0.52	0.04	-0.01	-20.25	-54.57	-51.49	-23.33	-9.80
		21	0.87	0.51	-0.05	0.51	-0.05	2.98e-03	-14.51	-94.60	-94.32	-14.79	-4.66
19	6	52	1.17	0.76	-0.24	0.76	-0.24	0.05	-27.70	-129.87	-129.76	-27.80	3.23
		51	0.63	0.87	0.11	0.72	0.27	-0.30	-37.33	-74.58	-65.40	-46.50	-16.05
		26	0.72	0.61	0.18	0.57	0.23	-0.13	-25.11	-82.47	-75.81	-31.77	-18.37
		21	1.16	0.49	-0.17	0.49	-0.17	-0.04	-12.86	-124.82	-124.76	-12.92	-2.56
19	38	52	1.10	0.76	-0.18	0.76	-0.17	0.08	-29.78	-123.09	-123.06	-29.81	1.69
		51	0.55	0.76	0.08	0.68	0.16	-0.22	-35.31	-64.35	-57.44	-42.22	-12.37
		26	0.61	0.57	0.11	0.57	0.12	-0.06	-22.20	-69.69	-64.99	-26.90	-14.19
		21	1.07	0.52	-0.09	0.52	-0.09	-0.02	-14.24	-115.33	-115.20	-14.36	-3.51
20	1	98	1.72	3.43	-1.98	2.74	-1.30	1.79	-131.10	-201.17	-170.18	-162.09	34.80
		97	0.70	2.84	-0.59	1.97	0.27	-1.49	-18.04	-74.16	-24.33	-67.87	-17.71
		31	0.71	1.36	0.23	1.35	0.24	0.11	-44.26	-83.62	-44.71	-83.17	-4.21
		19	1.56	0.36	-0.38	0.29	-0.31	-0.22	-66.36	-183.13	-182.68	-66.81	7.18
20	2	98	1.23	2.49	-1.41	1.99	-0.92	1.30	-92.41	-144.21	-123.13	-113.49	25.45
		97	0.48	2.05	-0.44	1.43	0.19	-1.08	-11.70	-50.17	-16.64	-45.22	-12.88
		31	0.50	0.99	0.16	0.98	0.17	0.08	-31.70	-59.04	-32.08	-58.66	-3.20
		19	1.14	0.26	-0.27	0.21	-0.22	-0.16	-46.99	-133.64	-133.27	-47.36	5.61

20	9	98	1.42	3.05	-1.63	2.61	-1.19	1.35	-84.08	-169.14	-143.30	-109.92	39.12
		97	0.29	3.08	-0.43	2.10	0.56	-1.57	-10.52	-28.00	-20.47	-18.05	-8.65
		31	0.44	1.23	0.46	1.20	0.50	-0.16	-34.52	-46.99	-44.14	-37.37	5.24
		19	1.46	0.23	-0.57	0.21	-0.55	-0.12	-41.09	-166.39	-162.62	-44.85	21.38
20	41	98	1.35	2.88	-1.54	2.39	-1.05	1.39	-89.94	-160.82	-138.41	-112.35	32.96
		97	0.39	2.60	-0.47	1.79	0.34	-1.35	-10.68	-38.52	-17.97	-31.24	-12.24
		31	0.46	1.13	0.32	1.13	0.32	-0.01	-38.68	-49.93	-38.71	-49.91	-0.53
		19	1.35	0.26	-0.40	0.21	-0.36	-0.16	-45.16	-156.03	-154.48	-46.71	13.04
21	1	63	1.25	1.13	-0.15	1.11	-0.13	-0.16	-41.37	-140.82	-140.82	-41.37	0.50
		62	0.64	0.79	-0.05	0.73	-2.09e-03	0.20	-49.22	-73.56	-66.08	-56.69	11.23
		32	0.61	1.12	0.28	1.09	0.31	0.15	-47.59	-69.35	-48.58	-68.36	4.53
		20	1.46	1.08	-0.59	1.08	-0.59	0.04	-82.03	-170.67	-170.60	-82.09	-2.33
21	2	63	0.92	0.81	-0.10	0.80	-0.09	-0.11	-29.55	-103.41	-103.41	-29.55	-0.12
		62	0.46	0.57	-0.04	0.53	-7.64e-04	0.15	-34.90	-53.12	-47.79	-40.24	8.30
		32	0.43	0.81	0.20	0.79	0.22	0.11	-34.05	-48.89	-34.91	-48.03	3.46
		20	1.06	0.78	-0.41	0.78	-0.41	0.03	-58.08	-124.52	-124.45	-58.15	-2.14
21	3	63	1.16	0.76	-0.33	0.75	-0.33	-0.09	-22.99	-126.66	-126.07	-23.57	-7.76
		62	0.55	0.82	-5.97e-03	0.57	0.25	0.38	-37.64	-62.96	-62.48	-38.12	-3.46
		32	0.53	1.20	0.28	0.98	0.50	0.40	-39.61	-57.85	-51.25	-46.21	-8.76
		20	1.33	0.89	-0.65	0.88	-0.64	0.11	-52.12	-153.23	-152.14	-53.21	-10.41
21	35	63	1.09	0.83	-0.19	0.82	-0.18	-0.10	-27.26	-121.05	-120.90	-27.41	-3.83
		62	0.50	0.68	-3.61e-03	0.58	0.10	0.25	-38.35	-57.74	-56.74	-39.35	4.30
		32	0.46	1.00	0.26	0.91	0.34	0.23	-43.38	-47.18	-43.55	-47.00	-0.79
		20	1.25	0.87	-0.51	0.87	-0.51	0.07	-56.13	-144.78	-144.34	-56.57	-6.27
22	1	85	1.16	1.27	-1.10	-0.97	1.14	0.54	-68.35	-138.70	-88.59	-118.45	31.85
		84	1.00	1.02	-0.52	-0.49	0.99	0.21	-33.00	-114.05	-42.66	-104.38	26.26
		34	0.56	1.19	0.23	0.27	1.16	-0.19	-39.81	-61.23	-41.39	-59.66	5.59
		56	0.54	1.56	0.33	0.48	1.41	-0.40	-43.40	-57.92	-57.08	-44.24	3.39
22	2	85	0.82	0.89	-0.79	-0.70	0.81	0.38	-48.37	-98.59	-63.24	-83.72	22.93
		84	0.71	0.72	-0.37	-0.35	0.70	0.15	-23.38	-81.09	-30.55	-73.92	19.04
		34	0.40	0.84	0.17	0.20	0.81	-0.14	-28.48	-43.64	-29.58	-42.54	3.92
		56	0.38	1.10	0.24	0.36	0.98	-0.29	-30.98	-41.20	-40.63	-31.55	2.36
22	25	85	1.12	0.93	-0.88	-0.74	0.79	0.49	-53.04	-132.56	-76.09	-109.52	36.08
		84	1.04	0.75	-0.41	-0.36	0.69	0.24	-30.15	-118.71	-43.32	-105.54	31.51
		34	0.65	0.78	0.15	0.15	0.78	-0.05	-41.74	-75.04	-42.62	-74.15	5.35
		56	0.55	1.02	0.26	0.32	0.95	-0.21	-50.25	-57.62	-52.39	-55.48	3.35
22	57	85	0.97	0.93	-0.86	-0.75	0.83	0.43	-50.37	-115.56	-69.15	-96.78	29.52
		84	0.87	0.76	-0.40	-0.37	0.73	0.19	-25.83	-98.77	-35.61	-88.98	24.86
		34	0.52	0.84	0.17	0.19	0.82	-0.11	-34.81	-58.76	-35.80	-57.76	4.77
		56	0.46	1.10	0.27	0.37	1.00	-0.27	-41.19	-48.06	-46.34	-42.91	2.98
23	1	87	0.78	1.08	-0.30	-0.16	0.93	0.43	-46.59	-91.80	-79.68	-58.71	-20.03
		86	0.89	1.58	-0.07	0.11	1.40	0.52	-49.64	-106.09	-104.71	-51.02	-8.71
		36	0.47	1.13	0.31	0.36	1.09	-0.19	-18.01	-54.02	-53.96	-18.08	1.52
		67	0.38	1.05	0.35	0.37	1.03	-0.12	-16.96	-44.22	-44.13	-17.06	1.61
23	2	87	0.56	0.77	-0.22	-0.11	0.67	0.31	-32.97	-65.11	-56.34	-41.74	-14.32
		86	0.63	1.12	-0.06	0.08	0.99	0.37	-35.18	-74.72	-73.75	-36.15	-6.11
		36	0.32	0.81	0.23	0.26	0.77	-0.13	-12.70	-37.03	-36.98	-12.75	1.11
		67	0.27	0.75	0.26	0.27	0.73	-0.08	-12.08	-30.81	-30.74	-12.15	1.14
23	12	87	0.91	0.90	-0.41	-0.25	0.74	0.43	-43.88	-107.87	-97.65	-54.10	-23.44
		86	0.99	1.17	-0.28	-0.07	0.97	0.50	-43.24	-117.46	-115.38	-45.32	-12.25
		36	0.42	0.90	0.24	0.32	0.82	-0.21	-15.53	-48.65	-48.64	-15.54	0.68
		67	0.38	0.92	0.29	0.35	0.86	-0.19	-18.05	-44.62	-44.40	-18.26	-2.40
23	44	87	0.71	0.85	-0.30	-0.17	0.72	0.37	-37.83	-83.32	-73.36	-47.78	-18.81
		86	0.78	1.18	-0.14	0.02	1.01	0.43	-39.02	-93.04	-91.42	-40.64	-9.22
		36	0.35	0.88	0.25	0.30	0.83	-0.17	-14.01	-40.74	-40.71	-14.04	0.97
		67	0.31	0.85	0.29	0.32	0.82	-0.13	-15.13	-36.15	-36.15	-15.13	-0.37

24	1	89	0.48	2.74	0.26	2.03	0.97	-1.12	-32.14	-53.64	-34.66	-51.12	-6.92
		88	0.96	3.43	3.06	3.06	3.42	6.65e-03	-77.43	-93.21	-78.14	-92.50	3.27
		35	0.36	2.18	0.73	1.10	1.81	-0.63	-23.07	-37.93	-31.81	-29.20	-7.32
		37	0.75	2.84	2.23	2.77	2.30	0.20	-63.49	-70.79	-68.46	-65.81	-3.40
24	2	89	0.33	1.97	0.15	1.45	0.67	-0.82	-22.47	-36.38	-24.52	-34.32	-4.94
		88	0.68	2.41	2.17	2.17	2.41	-3.36e-03	-54.71	-65.70	-55.32	-65.09	2.52
		35	0.25	1.54	0.51	0.79	1.27	-0.46	-16.04	-26.86	-22.20	-20.70	-5.36
		37	0.54	2.04	1.56	1.99	1.61	0.14	-45.85	-51.25	-49.35	-47.75	-2.58
24	25	89	0.39	2.18	0.13	1.68	0.64	-0.88	-30.86	-40.34	-30.99	-40.21	-1.09
		88	0.85	2.64	2.40	2.42	2.62	0.06	-61.18	-88.04	-63.86	-85.37	8.05
		35	0.39	1.67	0.96	1.15	1.47	-0.32	-24.94	-40.50	-27.06	-38.38	-5.34
		37	0.64	2.52	1.60	2.44	1.67	0.25	-53.96	-61.26	-56.06	-59.16	-3.31
24	57	89	0.35	2.16	0.11	1.62	0.65	-0.90	-26.91	-36.67	-28.05	-35.53	-3.13
		88	0.77	2.56	2.33	2.33	2.56	-7.13e-03	-58.03	-77.24	-59.87	-75.40	5.65
		35	0.31	1.65	0.71	0.96	1.40	-0.42	-20.21	-32.36	-23.97	-28.60	-5.62
		37	0.60	2.33	1.60	2.27	1.66	0.20	-51.10	-57.59	-54.03	-54.66	-3.23
25	1	91	1.75	1.13	0.09	0.13	1.09	-0.20	-66.60	-205.93	-203.54	-68.99	18.10
		90	1.92	1.46	-1.58	-1.43	1.31	-0.66	-126.28	-224.30	-224.30	-126.29	-0.64
		38	1.79	1.43	-0.07	0.12	1.23	0.50	-62.72	-209.05	-209.05	-62.72	0.01
		39	1.68	1.01	0.12	0.15	0.98	-0.16	-62.10	-197.46	-197.44	-62.12	-1.73
25	2	91	1.28	0.81	0.06	0.09	0.77	-0.15	-48.26	-150.31	-148.79	-49.78	12.34
		90	1.40	1.02	-1.14	-1.04	0.91	-0.47	-89.52	-163.72	-163.72	-89.52	-0.30
		38	1.31	1.00	-0.06	0.08	0.85	0.37	-45.31	-152.72	-152.72	-45.31	0.18
		39	1.23	0.71	0.08	0.10	0.69	-0.12	-44.79	-144.16	-144.15	-44.81	-1.31
25	6	91	1.56	0.91	0.02	0.07	0.86	-0.21	-54.69	-182.09	-180.61	-56.17	13.63
		90	1.66	0.95	-1.40	-1.22	0.77	-0.64	-94.26	-194.02	-194.00	-94.28	-1.40
		38	1.60	0.71	-0.22	-0.17	0.66	0.21	-51.20	-184.45	-184.44	-51.21	-1.17
		39	1.53	0.74	-0.15	-0.11	0.71	-0.16	-51.77	-177.55	-177.55	-51.77	0.53
25	38	91	1.50	0.87	0.03	0.08	0.82	-0.21	-53.63	-175.28	-173.97	-54.93	12.53
		90	1.60	0.99	-1.31	-1.18	0.85	-0.54	-93.56	-187.57	-187.56	-93.57	-0.51
		38	1.52	0.89	-0.14	-0.03	0.77	0.33	-50.24	-176.63	-176.63	-50.24	-0.20
		39	1.46	0.73	-0.02	6.21e-03	0.70	-0.15	-50.28	-169.64	-169.63	-50.28	-0.63
26	1	92	0.36	2.30	1.09	2.30	1.09	-1.75e-03	3.30	-33.62	2.93	-33.25	-3.68
		91	1.32	2.93	1.42	2.03	2.31	-0.74	-51.28	-150.44	-147.25	-54.47	-17.49
		39	0.98	1.88	1.04	1.18	1.75	0.31	-36.76	-111.28	-111.25	-36.79	1.43
		40	0.48	2.01	1.58	1.77	1.82	-0.21	-35.28	-47.12	-35.43	-46.98	-1.32
26	2	92	0.25	1.65	0.76	1.65	0.76	3.93e-03	2.11	-23.92	1.85	-23.67	-2.57
		91	0.96	2.09	1.02	1.47	1.63	-0.53	-36.60	-109.43	-106.93	-39.10	-13.26
		39	0.71	1.34	0.75	0.84	1.24	0.22	-26.88	-81.22	-81.21	-26.90	0.92
		40	0.36	1.43	1.13	1.27	1.29	-0.15	-26.58	-35.34	-26.69	-35.23	-0.99
26	31	92	0.28	2.05	0.73	2.04	0.73	0.06	0.46	-26.85	0.19	-26.59	-2.67
		91	1.12	2.30	1.31	1.91	1.70	-0.49	-40.11	-125.93	-123.46	-42.58	-14.34
		39	0.84	1.50	0.81	1.04	1.27	0.32	-30.62	-95.06	-94.98	-30.71	2.39
		40	0.41	1.53	1.23	1.47	1.29	-0.12	-29.45	-41.89	-29.51	-41.83	-0.85
26	63	92	0.27	1.90	0.76	1.89	0.76	0.04	2.38	-24.88	2.18	-24.68	-2.33
		91	1.10	2.25	1.18	1.75	1.68	-0.53	-39.54	-124.37	-121.68	-42.23	-14.86
		39	0.83	1.43	0.81	0.98	1.27	0.27	-30.62	-94.53	-94.50	-30.65	1.48
		40	0.40	1.52	1.21	1.41	1.32	-0.14	-28.63	-40.27	-28.71	-40.19	-0.98
27	1	86	0.59	2.40	0.91	1.38	1.94	0.69	-37.43	-65.27	-62.17	-40.52	8.75
		92	0.38	2.26	0.89	2.12	1.03	0.41	-8.82	-41.45	-15.47	-34.79	13.15
		40	0.46	1.90	1.66	1.82	1.74	0.11	-37.00	-43.68	-37.26	-43.43	1.29
		36	0.29	1.38	0.93	1.03	1.27	-0.19	-13.82	-30.78	-30.78	-13.82	-0.05
27	2	86	0.41	1.72	0.64	0.98	1.38	0.50	-26.21	-45.81	-43.32	-28.70	6.53
		92	0.27	1.62	0.61	1.52	0.71	0.30	-6.67	-30.04	-11.86	-24.86	9.71
		40	0.34	1.35	1.18	1.31	1.22	0.08	-28.03	-32.77	-28.25	-32.55	1.00
		36	0.20	0.97	0.66	0.73	0.90	-0.13	-9.67	-20.35	-20.35	-9.67	0.06

27	18	86	0.49	2.02	0.90	1.36	1.57	0.55	-32.72	-53.38	-50.99	-35.11	6.60
		92	0.33	2.02	0.41	1.93	0.51	0.38	-12.85	-37.07	-20.47	-29.45	11.25
		40	0.43	1.80	1.07	1.80	1.07	0.02	-37.11	-41.15	-37.98	-40.27	1.67
		36	0.26	1.41	0.91	1.21	1.11	-0.24	-15.23	-25.73	-25.69	-15.27	0.69
27	50	86	0.45	1.91	0.73	1.15	1.50	0.56	-29.37	-48.87	-46.43	-31.82	6.46
		92	0.30	1.86	0.52	1.76	0.63	0.36	-9.10	-33.66	-16.01	-26.76	11.04
		40	0.40	1.58	1.17	1.57	1.18	0.05	-33.24	-38.03	-33.67	-37.60	1.37
		36	0.21	1.17	0.80	0.95	1.02	-0.18	-12.00	-21.28	-21.26	-12.01	0.39
28	1	90	1.34	4.95	3.02	4.70	3.27	-0.65	-90.11	-138.09	-136.74	-91.46	7.94
		89	0.40	2.08	0.90	2.05	0.93	0.18	-21.23	-42.66	-26.37	-37.53	9.15
		37	0.76	2.87	2.31	2.82	2.37	-0.16	-60.79	-75.07	-61.35	-74.51	-2.77
		38	1.03	2.67	0.69	1.31	2.05	0.92	-38.91	-118.10	-115.53	-41.48	14.03
28	2	90	0.97	3.59	2.11	3.40	2.30	-0.49	-63.23	-100.23	-99.33	-64.13	5.69
		89	0.27	1.49	0.62	1.47	0.63	0.12	-14.14	-28.57	-18.28	-24.43	6.53
		37	0.55	2.06	1.62	2.03	1.66	-0.12	-43.76	-54.44	-44.13	-54.06	-1.96
		38	0.75	1.90	0.47	0.94	1.44	0.67	-28.41	-86.72	-84.86	-30.28	10.27
28	9	90	1.12	4.30	2.15	4.13	2.31	-0.57	-64.23	-116.25	-115.42	-65.07	6.52
		89	0.31	1.90	0.03	1.87	0.06	0.23	-15.48	-33.01	-24.28	-24.21	8.76
		37	0.64	3.07	1.27	3.06	1.29	-0.15	-52.38	-62.46	-52.82	-62.01	-2.06
		38	0.95	2.26	1.28	2.00	1.55	0.44	-32.25	-104.47	-102.63	-34.09	11.38
28	41	90	1.08	4.09	2.16	3.91	2.34	-0.56	-64.17	-113.06	-112.26	-64.98	6.22
		89	0.28	1.72	0.37	1.71	0.38	0.14	-13.67	-29.38	-20.79	-22.26	7.82
		37	0.61	2.57	1.52	2.55	1.54	-0.14	-48.70	-60.37	-49.11	-59.96	-2.16
		38	0.90	2.08	0.85	1.43	1.50	0.61	-32.08	-101.23	-99.30	-34.01	11.38
29	1	57	0.73	0.88	-0.02	0.86	-2.20e-03	-0.13	-48.97	-85.72	-63.57	-71.11	-17.98
		12	0.74	0.80	-0.38	0.08	0.34	-0.57	-47.97	-88.88	-52.81	-84.04	-13.21
		48	0.62	0.62	0.27	0.28	0.61	0.05	-24.60	-70.95	-30.69	-64.86	-15.66
		55	1.14	0.32	-0.50	0.01	-0.19	-0.40	-89.56	-133.72	-132.76	-90.52	-6.46
29	2	57	0.52	0.62	-0.02	0.61	-2.25e-03	-0.09	-33.89	-61.56	-45.08	-50.37	-13.58
		12	0.53	0.57	-0.27	0.06	0.24	-0.41	-33.92	-63.40	-37.74	-59.58	-9.90
		48	0.44	0.44	0.19	0.20	0.44	0.03	-17.06	-50.65	-21.96	-45.76	-11.85
		55	0.81	0.23	-0.36	9.33e-03	-0.14	-0.28	-63.28	-95.64	-94.86	-64.05	-4.95
29	29	57	3.94	0.47	-0.41	0.45	-0.39	-0.13	-73.95	-439.91	-81.79	-432.06	53.01
		12	0.58	0.35	-0.52	-0.12	-0.05	-0.43	-1.10	-60.47	-1.65	-59.92	5.66
		48	2.73	0.23	0.05	0.10	0.18	0.08	56.21	-251.66	-125.15	-70.30	151.47
		55	5.19	0.04	-0.67	-0.11	-0.52	-0.29	-121.86	-590.97	-258.09	-454.74	212.95
29	61	57	1.83	0.58	-0.18	0.57	-0.17	-0.11	-55.82	-210.71	-57.04	-209.50	13.65
		12	0.49	0.50	-0.39	-0.01	0.13	-0.44	-20.29	-57.38	-20.46	-57.22	-2.45
		48	1.09	0.36	0.15	0.17	0.35	0.05	-1.98	-114.77	-64.66	-52.10	56.05
		55	2.37	0.15	-0.50	-0.04	-0.31	-0.30	-94.77	-279.33	-155.95	-218.15	86.88
30	1	68	1.07	1.10	-1.63	-1.56	1.04	-0.41	-73.70	-123.62	-120.10	-77.22	12.78
		13	2.38	1.43	-4.00	-1.32	-1.25	2.71	-158.19	-269.66	-213.67	-214.18	55.73
		50	1.00	0.99	-1.38	0.95	-1.33	-0.32	-76.57	-115.08	-82.22	-109.42	13.63
		66	1.22	1.58	-1.33	0.16	0.09	1.45	-107.51	-136.09	-111.27	-132.33	-9.66
30	2	68	0.77	0.79	-1.16	-1.12	0.74	-0.30	-52.34	-88.36	-85.68	-55.02	9.44
		13	1.69	1.01	-2.86	-0.95	-0.90	1.93	-112.16	-191.81	-151.84	-152.13	39.82
		50	0.71	0.70	-0.99	0.67	-0.95	-0.23	-54.32	-82.21	-58.61	-77.92	10.06
		66	0.86	1.13	-0.96	0.11	0.06	1.04	-75.86	-96.45	-78.44	-93.87	-6.82
30	28	68	4.03	0.46	-1.90	-1.89	0.45	-0.13	-130.92	-466.36	-158.76	-438.52	92.54
		13	2.60	0.71	-4.28	-1.84	-1.73	2.49	-87.16	-285.70	-167.23	-205.63	97.40
		50	3.54	0.50	-1.66	0.50	-1.66	6.01e-03	60.61	-333.42	-134.00	-138.81	197.00
		66	5.29	1.05	-1.28	-0.05	-0.18	1.17	-97.11	-586.85	-209.52	-474.44	205.95
30	60	68	1.97	0.67	-1.52	-1.49	0.65	-0.24	-97.86	-233.17	-114.78	-216.25	44.75
		13	2.09	0.90	-3.60	-1.40	-1.30	2.25	-101.86	-234.64	-160.29	-176.22	65.91
		50	1.75	0.64	-1.31	0.63	-1.30	-0.14	-7.57	-185.44	-91.52	-101.49	88.80
		66	2.50	1.14	-1.16	0.03	-0.05	1.15	-83.06	-286.72	-124.40	-245.38	81.92

31	1	31	0.75	1.12	-3.89e-03	1.09	0.03	0.18	-46.28	-87.84	-59.79	-74.32	-19.47
		15	0.90	1.06	-0.64	0.80	-0.38	-0.62	-64.80	-105.90	-84.31	-86.39	-20.52
		49	0.78	0.57	-0.44	0.48	-0.35	-0.29	-43.71	-92.90	-70.53	-66.07	-24.50
		51	0.67	1.01	0.15	1.00	0.16	0.09	-37.96	-77.36	-65.72	-49.60	-17.97
31	2	31	0.54	0.80	3.28e-04	0.78	0.02	0.12	-32.76	-62.65	-43.11	-52.30	-14.22
		15	0.64	0.76	-0.46	0.57	-0.27	-0.44	-45.01	-75.82	-59.87	-60.96	-15.40
		49	0.56	0.41	-0.31	0.35	-0.25	-0.20	-30.08	-66.74	-50.11	-46.72	-18.25
		51	0.49	0.73	0.11	0.72	0.12	0.06	-26.89	-56.00	-47.68	-35.21	-13.15
31	6	31	0.88	0.92	0.18	0.88	0.23	0.18	-51.08	-102.15	-88.41	-64.81	-22.65
		15	1.14	0.89	-0.80	0.56	-0.47	-0.68	-21.50	-125.79	-95.82	-51.47	-47.20
		49	1.16	0.41	-0.71	0.17	-0.48	-0.46	-12.38	-124.72	-99.92	-37.18	-46.59
		51	0.97	0.67	0.28	0.66	0.30	0.08	-47.12	-113.80	-109.37	-51.55	-16.61
31	37	31	0.71	0.88	0.08	0.86	0.11	0.15	-40.91	-82.01	-64.77	-58.15	-20.28
		15	0.84	0.82	-0.62	0.58	-0.37	-0.54	-32.99	-97.72	-74.45	-56.26	-31.06
		49	0.79	0.41	-0.48	0.29	-0.36	-0.29	-19.94	-89.55	-69.36	-40.13	-31.59
		51	0.72	0.74	0.19	0.73	0.20	0.07	-35.86	-83.79	-76.61	-43.04	-17.10
32	1	17	2.49	1.36	-2.29	-1.09	0.16	-1.71	-148.83	-291.32	-279.57	-160.58	-39.19
		19	1.20	1.86	-0.73	0.75	0.39	1.28	-31.84	-135.03	-134.87	-31.99	4.02
		52	1.34	0.69	-0.25	0.16	0.27	0.47	-38.49	-153.60	-152.75	-39.34	-9.84
		53	1.99	1.18	-0.81	0.43	-0.05	-0.97	-85.34	-234.69	-234.20	-85.83	-8.58
32	2	17	1.80	0.97	-1.63	-0.77	0.11	-1.22	-105.89	-211.24	-203.24	-113.88	-27.90
		19	0.88	1.32	-0.51	0.53	0.27	0.90	-22.83	-99.70	-99.54	-22.99	3.52
		52	0.98	0.48	-0.17	0.12	0.19	0.32	-27.74	-112.96	-112.46	-28.24	-6.49
		53	1.45	0.85	-0.57	0.32	-0.04	-0.69	-60.46	-170.82	-170.49	-60.78	-5.99
32	19	17	2.06	1.10	-1.43	-0.54	0.21	-1.21	-105.56	-242.49	-233.34	-114.71	-34.19
		19	1.09	1.56	-0.26	0.88	0.42	0.88	-27.95	-121.48	-121.47	-27.95	-0.51
		52	1.21	0.63	0.10	0.40	0.33	0.26	-32.60	-137.63	-136.35	-33.88	-11.54
		53	1.72	1.03	-0.37	0.62	0.04	-0.64	-58.02	-198.61	-197.71	-58.92	-11.19
32	51	17	2.03	1.05	-1.60	-0.70	0.15	-1.26	-108.37	-237.78	-229.57	-116.57	-31.53
		19	1.05	1.46	-0.42	0.71	0.34	0.92	-25.36	-117.30	-117.21	-25.46	2.92
		52	1.16	0.54	-0.04	0.25	0.25	0.29	-30.71	-132.43	-131.81	-31.33	-7.94
		53	1.67	0.95	-0.49	0.47	-0.01	-0.68	-60.24	-194.21	-193.69	-60.77	-8.40
33	1	29	0.59	2.96	-0.71	1.86	0.39	1.68	43.81	-6.16	23.22	14.43	24.59
		17	1.72	3.34	-1.75	2.77	-1.18	-1.61	-116.25	-203.36	-166.05	-153.57	-43.11
		53	1.68	1.64	-0.78	1.48	-0.62	-0.60	-68.88	-195.47	-182.42	-81.93	-38.49
		54	0.45	2.09	1.77e-03	1.84	0.25	0.68	23.88	-20.97	20.48	-17.57	11.87
33	2	29	0.43	2.14	-0.52	1.35	0.28	1.22	33.42	-2.67	17.48	13.26	17.92
		17	1.22	2.42	-1.25	2.00	-0.84	-1.16	-82.52	-145.22	-119.91	-107.83	-30.76
		53	1.22	1.19	-0.56	1.07	-0.44	-0.43	-48.49	-141.22	-132.21	-57.50	-27.46
		54	0.32	1.51	-3.70e-03	1.33	0.18	0.50	18.13	-13.63	15.47	-10.97	8.80
33	3	29	0.56	2.16	-0.68	1.34	0.14	1.29	36.68	-17.57	10.94	8.17	27.09
		17	1.34	2.49	-1.19	2.11	-0.80	-1.13	-85.21	-159.30	-139.30	-105.22	-32.89
		53	1.44	1.20	-0.44	1.13	-0.37	-0.32	-47.33	-164.02	-156.71	-54.64	-28.27
		54	0.44	1.57	-0.09	1.40	0.08	0.50	15.00	-30.58	5.65	-21.23	18.40
33	35	29	0.51	2.27	-0.64	1.43	0.20	1.32	39.40	-6.06	17.07	16.27	22.73
		17	1.32	2.61	-1.27	2.18	-0.84	-1.22	-84.47	-156.78	-134.66	-106.59	-33.32
		53	1.39	1.26	-0.52	1.16	-0.42	-0.41	-47.73	-158.81	-150.51	-56.02	-29.20
		54	0.37	1.63	-0.05	1.45	0.13	0.53	19.08	-18.52	13.40	-12.84	13.47
34	1	13	1.81	1.72	-2.32	1.27	-1.87	1.26	-91.85	-206.65	-103.43	-195.06	34.58
		29	0.31	2.07	0.51	1.51	1.07	-0.74	17.33	-12.21	0.61	4.51	-14.64
		54	0.24	1.65	0.64	1.58	0.71	-0.25	-3.59	-24.13	-5.45	-22.27	5.89
		50	1.14	0.88	-1.42	0.73	-1.27	0.56	-70.46	-133.86	-102.60	-101.72	31.70
34	2	13	1.29	1.21	-1.66	0.89	-1.34	0.90	-64.97	-146.96	-73.18	-138.75	24.61
		29	0.22	1.48	0.39	1.09	0.77	-0.52	13.85	-7.70	0.54	5.61	-10.47
		54	0.16	1.18	0.47	1.13	0.51	-0.18	-2.26	-16.20	-3.89	-14.57	4.48
		50	0.81	0.62	-1.02	0.52	-0.91	0.40	-49.77	-95.14	-72.70	-72.21	22.68

34	14	13	1.75	1.52	-2.33	1.05	-1.87	1.25	-62.16	-194.51	-94.32	-162.34	56.77
		29	0.41	1.96	0.54	1.48	1.01	-0.67	26.38	-19.66	-13.90	20.63	-15.23
		54	0.35	1.43	0.59	1.33	0.69	-0.28	-6.84	-34.18	-33.78	-7.23	3.27
		50	1.36	0.76	-1.71	0.50	-1.46	0.74	-42.21	-153.61	-106.64	-89.17	55.01
34	46	13	1.50	1.36	-2.00	0.97	-1.61	1.08	-64.85	-169.38	-83.01	-151.22	39.60
		29	0.31	1.72	0.51	1.32	0.91	-0.57	21.48	-11.36	-5.37	15.49	-12.68
		54	0.21	1.33	0.55	1.27	0.61	-0.21	-8.06	-19.75	-17.07	-10.74	4.92
		50	1.04	0.68	-1.34	0.52	-1.18	0.55	-45.14	-119.63	-87.17	-77.60	36.94
35	1	19	1.46	1.08	-0.59	1.08	-0.59	-0.04	-82.03	-170.67	-170.60	-82.09	2.33
		31	0.61	1.12	0.28	1.09	0.31	-0.15	-47.59	-69.35	-48.58	-68.36	-4.53
		51	0.64	0.79	-0.05	0.73	-2.09e-03	-0.20	-49.22	-73.56	-66.08	-56.69	-11.23
		52	1.25	1.13	-0.15	1.11	-0.13	0.16	-41.37	-140.82	-140.82	-41.37	-0.50
35	2	19	1.06	0.78	-0.41	0.78	-0.41	-0.03	-58.08	-124.52	-124.45	-58.15	2.14
		31	0.43	0.81	0.20	0.79	0.22	-0.11	-34.05	-48.89	-34.91	-48.03	-3.46
		51	0.46	0.57	-0.04	0.53	-7.64e-04	-0.15	-34.90	-53.12	-47.79	-40.24	-8.30
		52	0.92	0.81	-0.10	0.80	-0.09	0.11	-29.55	-103.41	-103.41	-29.55	0.12
35	6	19	1.32	0.94	-0.59	0.93	-0.58	-0.15	-55.15	-152.59	-152.21	-55.53	6.07
		31	0.55	1.18	0.29	1.02	0.46	-0.35	-53.26	-55.48	-53.55	-55.19	0.74
		51	0.59	0.84	0.03	0.65	0.21	-0.34	-46.19	-67.58	-66.21	-47.55	-5.22
		52	1.17	0.85	-0.26	0.85	-0.26	0.04	-26.28	-128.71	-128.64	-26.35	2.77
35	38	19	1.25	0.89	-0.48	0.89	-0.48	-0.09	-57.32	-144.59	-144.37	-57.55	4.46
		31	0.48	1.00	0.26	0.93	0.33	-0.22	-43.59	-51.67	-44.51	-50.75	-2.56
		51	0.53	0.70	1.04e-03	0.61	0.09	-0.23	-39.89	-61.70	-58.30	-43.29	-7.92
		52	1.10	0.86	-0.15	0.86	-0.15	0.08	-28.54	-122.00	-121.97	-28.57	1.74
36	1	49	0.69	0.62	0.29	0.62	0.29	4.15e-03	-41.40	-81.07	-58.36	-64.11	-19.62
		55	1.07	0.39	-0.42	0.19	-0.21	-0.36	-53.32	-126.55	-71.94	-107.93	-31.89
		44	0.69	0.54	0.02	0.52	0.04	0.09	-19.37	-77.09	-73.13	-23.32	-14.59
		8	0.72	0.36	0.05	0.26	0.15	-0.15	-14.75	-81.51	-60.75	-35.51	-30.90
36	2	49	0.50	0.44	0.21	0.44	0.21	3.32e-03	-28.91	-58.37	-41.80	-45.48	-14.62
		55	0.77	0.28	-0.30	0.13	-0.15	-0.25	-36.42	-90.38	-50.56	-76.24	-23.72
		44	0.50	0.38	0.02	0.37	0.03	0.07	-13.38	-55.41	-52.33	-16.46	-10.96
		8	0.52	0.26	0.04	0.18	0.11	-0.10	-9.67	-58.74	-43.35	-25.05	-22.76
36	29	49	3.45	0.68	0.42	0.64	0.46	-0.10	221.86	-191.05	81.91	-51.10	-195.45
		55	4.93	0.51	-0.14	0.31	0.06	-0.30	491.61	-38.58	160.12	292.91	-256.64
		44	3.37	0.76	0.29	0.75	0.29	0.04	343.44	-14.79	13.90	314.75	-97.24
		8	1.07	0.71	0.24	0.56	0.40	-0.22	2.77	-110.02	-50.10	-57.15	-56.28
36	61	49	1.58	0.55	0.32	0.54	0.32	-0.04	77.08	-111.96	9.49	-44.37	-90.60
		55	2.17	0.39	-0.24	0.21	-0.07	-0.28	190.41	-56.28	47.14	86.99	-121.73
		44	1.52	0.55	0.13	0.54	0.14	0.06	136.72	-35.95	-21.99	122.76	-47.07
		8	0.73	0.46	0.12	0.35	0.23	-0.16	-2.24	-76.37	-43.49	-35.12	-36.83
37	1	96	2.19	1.88	-4.37	-1.05	-1.44	-3.12	-140.15	-245.18	-181.76	-203.56	-51.37
		93	1.01	1.58	-0.88	-0.57	1.28	-0.81	-79.04	-116.47	-83.70	-111.81	-12.36
		57	0.92	0.83	-1.65	-0.26	-0.56	-1.23	-75.00	-101.88	-86.33	-90.54	-13.28
		15	0.61	1.31	-0.62	1.24	-0.55	0.35	-58.31	-64.71	-63.14	-59.87	2.75
37	2	96	1.55	1.33	-3.10	-0.76	-1.01	-2.21	-98.76	-174.01	-129.20	-143.57	-36.93
		93	0.72	1.12	-0.63	-0.41	0.90	-0.58	-56.14	-82.86	-59.89	-79.11	-9.28
		57	0.66	0.59	-1.17	-0.18	-0.40	-0.87	-52.46	-72.98	-61.42	-64.03	-10.18
		15	0.43	0.93	-0.44	0.89	-0.39	0.25	-41.87	-45.54	-45.13	-42.28	1.16
37	19	96	2.28	1.51	-3.94	-0.94	-1.50	-2.71	-127.45	-258.26	-165.05	-220.67	-59.20
		93	1.58	1.25	-1.12	-0.54	0.66	-1.02	-92.18	-188.90	-97.62	-183.47	-22.27
		57	1.59	0.61	-1.94	-0.55	-0.78	-1.27	-38.30	-174.53	-57.78	-155.05	-47.68
		15	1.16	0.57	-0.89	0.57	-0.89	-0.02	-14.26	-124.26	-37.56	-100.95	-44.95
37	51	96	1.91	1.44	-3.58	-0.88	-1.26	-2.50	-112.88	-214.59	-147.27	-180.21	-48.11
		93	1.09	1.19	-0.85	-0.49	0.83	-0.78	-71.90	-129.57	-76.31	-125.16	-15.32
		57	1.00	0.62	-1.54	-0.34	-0.57	-1.07	-44.54	-113.25	-57.13	-100.66	-26.58
		15	0.64	0.81	-0.63	0.79	-0.62	0.14	-29.37	-75.62	-40.43	-64.56	-19.72

38	1	61	0.75	0.58	-0.41	0.55	-0.39	-0.15	-40.26	-89.83	-55.04	-75.06	22.67
		59	0.84	0.88	-0.20	0.58	0.10	0.48	-62.06	-97.11	-72.78	-86.39	-16.15
		58	0.83	-0.11	-0.28	-0.28	-0.11	-0.02	-60.67	-97.51	-92.06	-66.12	13.08
		16	0.86	0.64	-0.74	0.06	-0.16	0.68	-80.02	-95.93	-91.97	-83.98	6.88
38	2	61	0.54	0.41	-0.29	0.39	-0.28	-0.10	-28.02	-64.62	-39.44	-53.20	16.96
		59	0.59	0.63	-0.14	0.42	0.07	0.34	-44.01	-68.16	-51.15	-61.02	-11.02
		58	0.59	-0.08	-0.20	-0.20	-0.08	-0.01	-42.45	-70.23	-65.86	-46.82	10.11
		16	0.62	0.45	-0.52	0.04	-0.11	0.48	-56.06	-68.82	-65.56	-59.32	5.56
38	25	61	3.45	0.35	-0.63	0.35	-0.63	0.03	112.46	-290.02	-101.30	-76.26	200.85
		59	5.03	0.55	-0.51	0.37	-0.33	0.39	-65.49	-550.56	-175.06	-440.99	202.84
		58	3.92	-0.56	-0.59	-0.59	-0.56	4.12e-03	-101.82	-447.88	-121.03	-428.67	79.24
		16	0.96	0.22	-1.06	-0.32	-0.52	0.63	-13.34	-101.71	-47.94	-67.10	43.14
38	57	61	1.70	0.40	-0.44	0.39	-0.44	-0.05	33.07	-157.79	-65.29	-59.44	95.38
		59	2.21	0.62	-0.30	0.42	-0.10	0.38	-53.40	-249.99	-92.96	-210.42	78.82
		58	1.85	-0.29	-0.37	-0.37	-0.29	-7.30e-03	-74.64	-218.14	-86.89	-205.88	40.11
		16	0.71	0.37	-0.77	-0.11	-0.29	0.56	-34.85	-81.44	-56.56	-59.73	23.24
39	1	88	1.78	2.42	-2.65	-2.20	1.97	1.44	-99.01	-202.77	-181.11	-120.67	42.17
		85	1.17	1.03	-1.08	-0.99	0.94	0.42	-66.13	-139.56	-82.42	-123.27	30.51
		56	0.56	1.56	0.42	0.49	1.49	-0.28	-40.66	-62.91	-61.38	-42.19	5.63
		35	0.43	2.56	0.17	1.01	1.72	-1.14	-20.10	-49.13	-40.18	-29.06	-13.41
39	2	88	1.27	1.68	-1.89	-1.58	1.38	1.00	-69.86	-144.18	-128.90	-85.14	30.04
		85	0.83	0.73	-0.77	-0.71	0.67	0.29	-46.86	-99.11	-58.86	-87.11	21.98
		56	0.40	1.09	0.31	0.36	1.04	-0.20	-29.05	-44.74	-43.68	-30.11	3.94
		35	0.30	1.81	0.13	0.74	1.20	-0.81	-14.24	-34.78	-28.32	-20.70	-9.54
39	7	88	1.79	1.85	-2.10	-1.65	1.41	1.25	-86.55	-204.18	-186.46	-104.27	42.07
		85	1.24	0.87	-0.86	-0.73	0.73	0.47	-76.11	-147.47	-112.35	-111.22	35.68
		56	0.63	1.04	0.08	0.08	1.04	7.66e-03	-44.63	-74.13	-71.65	-47.12	8.19
		35	0.48	1.52	0.16	0.49	1.19	-0.58	-28.32	-56.32	-53.13	-31.52	-8.91
39	41	88	1.52	1.81	-2.07	-1.69	1.43	1.16	-78.65	-172.73	-155.09	-96.29	36.72
		85	1.01	0.81	-0.86	-0.76	0.71	0.40	-60.09	-120.80	-80.42	-100.47	28.65
		56	0.51	1.08	0.25	0.27	1.06	-0.12	-37.97	-58.21	-56.51	-39.67	5.61
		35	0.38	1.75	0.19	0.68	1.25	-0.73	-21.25	-44.11	-38.54	-26.81	-9.81
40	1	15	0.86	0.64	-0.74	0.06	-0.16	-0.68	-80.02	-95.93	-91.97	-83.98	-6.88
		57	0.83	-0.11	-0.28	-0.28	-0.11	0.02	-60.67	-97.51	-92.06	-66.12	-13.08
		55	0.84	0.88	-0.20	0.58	0.10	-0.48	-62.06	-97.11	-72.78	-86.39	16.15
		49	0.75	0.58	-0.41	0.55	-0.39	0.15	-40.26	-89.83	-55.04	-75.06	-22.67
40	2	15	0.62	0.45	-0.52	0.04	-0.11	-0.48	-56.06	-68.82	-65.56	-59.32	-5.56
		57	0.59	-0.08	-0.20	-0.20	-0.08	0.01	-42.45	-70.23	-65.86	-46.82	-10.11
		55	0.59	0.63	-0.14	0.42	0.07	-0.34	-44.01	-68.16	-51.15	-61.02	11.02
		49	0.54	0.41	-0.29	0.39	-0.28	0.10	-28.02	-64.62	-39.44	-53.20	-16.96
40	19	15	0.96	0.22	-1.06	-0.32	-0.52	-0.63	-13.34	-101.71	-47.94	-67.10	-43.14
		57	3.92	-0.56	-0.59	-0.59	-0.56	-4.12e-03	-101.82	-447.88	-121.03	-428.67	-79.24
		55	5.03	0.55	-0.51	0.37	-0.33	-0.39	-65.49	-550.56	-175.06	-440.99	-202.84
		49	3.45	0.35	-0.63	0.35	-0.63	-0.03	112.46	-290.02	-101.30	-76.27	-200.85
40	51	15	0.71	0.37	-0.77	-0.11	-0.29	-0.56	-34.85	-81.44	-56.56	-59.73	-23.24
		57	1.85	-0.29	-0.37	-0.37	-0.29	7.30e-03	-74.64	-218.14	-86.89	-205.88	-40.11
		55	2.21	0.62	-0.30	0.42	-0.10	-0.38	-53.40	-249.99	-92.96	-210.42	-78.82
		49	1.70	0.40	-0.44	0.39	-0.44	0.05	33.07	-157.79	-65.29	-59.44	-95.38
41	1	43	0.36	0.01	-0.18	-0.11	-0.06	-0.09	-21.86	-43.15	-41.05	-23.96	6.35
		2	0.46	0.35	-0.16	0.09	0.10	0.25	-29.37	-54.59	-42.62	-41.34	12.60
		46	0.46	0.09	-0.21	0.09	-0.21	-0.02	-30.47	-53.99	-30.63	-53.82	1.96
		59	1.34	0.74	-0.08	0.47	0.18	0.39	-87.55	-160.77	-135.03	-113.29	34.96
41	2	43	0.26	8.24e-03	-0.13	-0.08	-0.04	-0.07	-15.04	-30.89	-29.00	-16.93	5.14
		2	0.33	0.25	-0.11	0.06	0.07	0.18	-20.01	-39.42	-30.28	-29.15	9.69
		46	0.32	0.07	-0.15	0.07	-0.15	-0.02	-21.68	-38.22	-21.92	-37.98	1.99
		59	0.96	0.53	-0.06	0.34	0.13	0.27	-61.14	-115.46	-96.46	-80.14	25.90

41	29	43	3.14	-0.15	-0.29	-0.20	-0.24	-0.06	-64.92	-354.20	-72.74	-346.38	46.91
		2	0.37	0.13	-0.29	-0.04	-0.12	0.20	30.86	-11.16	-1.97	21.67	17.37
		46	2.71	-0.03	-0.36	-0.03	-0.36	-4.82e-03	125.54	-197.75	-71.32	-0.88	157.76
		59	4.95	0.44	-0.24	0.26	-0.05	0.30	-75.62	-547.43	-213.85	-409.20	214.73
41	61	43	1.38	-0.06	-0.20	-0.13	-0.13	-0.07	-38.38	-158.40	-43.12	-153.67	23.36
		2	0.29	0.21	-0.19	0.02	-6.78e-03	0.20	5.44	-26.17	-15.83	-4.90	14.83
		46	1.18	0.03	-0.24	0.03	-0.24	-0.01	38.41	-99.08	-42.22	-18.45	67.71
		59	2.52	0.51	-0.14	0.32	0.06	0.30	-60.81	-286.36	-138.43	-208.75	107.15
42	1	41	0.86	1.02	5.02e-03	1.00	0.02	0.13	-35.75	-97.21	-95.81	-37.16	-9.18
		5	0.85	0.61	-0.01	0.37	0.22	-0.30	-28.17	-98.69	-82.28	-44.59	-29.80
		60	1.08	0.83	0.29	0.83	0.29	-0.03	-82.98	-124.78	-101.82	-105.94	-20.80
		69	1.31	0.53	-1.15	-0.36	-0.26	-0.84	-81.24	-153.11	-100.04	-134.31	-31.59
42	2	41	0.61	0.73	2.56e-03	0.72	0.01	0.09	-25.41	-69.47	-68.41	-26.47	-6.76
		5	0.61	0.43	-0.01	0.26	0.16	-0.22	-19.71	-70.56	-58.61	-31.66	-21.56
		60	0.77	0.59	0.20	0.59	0.20	-0.02	-58.94	-89.04	-72.57	-75.41	-14.98
		69	0.93	0.38	-0.83	-0.26	-0.19	-0.60	-56.67	-109.11	-70.45	-95.32	-23.08
42	28	41	3.27	0.45	-0.27	0.44	-0.25	0.11	-96.28	-376.90	-122.67	-350.51	81.91
		5	0.53	0.07	-0.15	-0.04	-0.04	-0.11	20.03	-42.58	-39.84	17.29	12.82
		60	3.26	0.60	0.02	0.58	0.05	0.11	53.37	-309.22	-200.28	-55.57	166.23
		69	5.04	0.25	-1.00	-0.34	-0.40	-0.62	-110.56	-569.89	-248.65	-431.80	210.62
42	60	41	1.45	0.64	-0.11	0.63	-0.10	0.10	-77.88	-172.99	-89.24	-161.63	30.84
		5	0.45	0.30	-0.07	0.14	0.08	-0.18	-7.28	-50.07	-49.01	-8.34	-6.65
		60	1.48	0.60	0.13	0.60	0.14	0.04	-28.01	-165.01	-127.68	-65.34	61.00
		69	2.29	0.34	-0.94	-0.32	-0.28	-0.64	-94.38	-269.64	-135.81	-228.21	74.46
43	1	25	0.66	0.68	-0.14	0.67	-0.13	0.11	-23.15	-75.55	-69.23	-29.48	17.07
		7	0.74	0.71	0.13	0.71	0.13	-0.03	-18.46	-82.61	-63.41	-37.67	29.38
		61	0.79	0.73	-0.05	0.58	0.10	0.31	-42.47	-95.15	-70.45	-67.17	26.29
		62	0.66	0.96	-0.14	0.95	-0.13	-0.11	-38.36	-76.73	-65.93	-49.16	17.25
43	2	25	0.48	0.49	-0.10	0.48	-0.09	0.08	-16.48	-55.03	-50.43	-21.08	12.50
		7	0.54	0.51	0.09	0.51	0.09	-0.02	-12.32	-59.44	-45.11	-26.64	21.68
		61	0.57	0.52	-0.04	0.41	0.07	0.22	-29.19	-68.35	-50.05	-47.49	19.54
		62	0.48	0.69	-0.10	0.68	-0.09	-0.08	-27.17	-55.56	-47.84	-34.89	12.63
43	7	25	0.97	0.29	3.77e-03	0.28	0.02	0.06	-24.15	-110.32	-99.52	-34.95	28.53
		7	0.78	0.34	-0.10	0.26	-0.02	0.17	-17.00	-87.66	-82.42	-22.24	18.52
		61	0.89	0.56	-0.30	0.28	-0.02	0.40	-37.17	-105.08	-99.01	-43.24	19.37
		62	1.04	0.65	0.01	0.62	0.04	-0.13	-38.38	-120.22	-107.08	-51.52	30.05
43	39	25	0.73	0.43	-0.06	0.42	-0.05	0.07	-19.51	-82.21	-74.74	-26.98	20.32
		7	0.62	0.44	0.04	0.43	0.05	0.05	-13.14	-68.54	-59.28	-22.41	20.67
		61	0.68	0.55	-0.14	0.37	0.04	0.31	-31.00	-80.54	-69.34	-42.20	20.72
		62	0.75	0.71	-0.05	0.69	-0.04	-0.10	-32.14	-86.30	-76.14	-42.29	21.14
44	1	24	1.93	1.06	-0.37	0.76	-0.07	0.59	-40.11	-215.02	-214.90	-40.23	4.56
		22	1.42	0.42	0.05	0.31	0.15	-0.16	-26.60	-158.45	-157.76	-27.29	9.54
		63	1.33	0.75	-0.19	0.29	0.27	-0.47	-37.45	-152.12	-151.49	-38.08	8.49
		64	2.00	1.09	-0.85	0.27	-0.03	0.96	-86.31	-237.30	-236.53	-87.08	10.75
44	2	24	1.41	0.77	-0.26	0.55	-0.05	0.42	-28.37	-156.68	-156.61	-28.45	3.12
		22	1.05	0.29	0.04	0.23	0.11	-0.11	-19.19	-116.48	-116.06	-19.61	6.38
		63	0.98	0.53	-0.13	0.21	0.19	-0.32	-26.98	-111.90	-111.54	-27.34	5.51
		64	1.46	0.78	-0.60	0.20	-0.02	0.68	-61.16	-172.70	-172.18	-61.68	7.55
44	25	24	1.68	1.00	-0.12	0.86	0.02	0.37	-27.85	-184.03	-183.69	-28.19	7.29
		22	1.29	0.53	0.21	0.51	0.23	-0.08	-24.38	-143.09	-141.67	-25.79	12.88
		63	1.21	0.72	0.09	0.50	0.31	-0.30	-32.23	-136.73	-135.45	-33.50	11.47
		64	1.72	0.95	-0.41	0.49	0.05	0.64	-61.43	-200.61	-199.62	-62.43	11.71
44	57	24	1.63	0.90	-0.20	0.72	-0.02	0.40	-28.34	-179.15	-178.98	-28.51	5.05
		22	1.24	0.40	0.13	0.36	0.16	-0.09	-22.12	-137.04	-136.39	-22.76	8.56
		63	1.16	0.61	-0.02	0.35	0.24	-0.31	-30.08	-131.37	-130.84	-30.60	7.30
		64	1.68	0.88	-0.53	0.35	6.55e-03	0.68	-62.10	-196.27	-195.57	-62.80	9.61

45	1	27	0.28	1.54	0.23	1.48	0.30	-0.28	6.24	-22.18	4.78	-20.72	-6.27
		24	1.63	1.34	-0.41	1.32	-0.39	0.16	-31.50	-177.74	-171.47	-37.77	29.64
		64	1.66	1.83	-0.92	1.65	-0.74	0.68	-69.16	-192.50	-178.97	-82.69	38.54
		65	0.43	2.09	0.08	1.73	0.44	-0.78	22.29	-20.72	18.36	-16.79	-12.39
45	2	27	0.20	1.11	0.17	1.06	0.21	-0.20	5.23	-15.27	4.01	-14.06	-4.85
		24	1.18	0.97	-0.29	0.96	-0.28	0.11	-22.14	-128.94	-124.56	-26.52	21.18
		64	1.20	1.32	-0.66	1.19	-0.53	0.49	-48.70	-139.05	-129.70	-58.05	27.52
		65	0.31	1.51	0.05	1.25	0.31	-0.56	17.00	-13.48	13.92	-10.40	-9.19
45	25	27	0.25	1.37	0.15	1.34	0.17	-0.17	1.99	-22.65	-4.29	-16.37	-10.74
		24	1.42	1.23	-0.22	1.23	-0.22	0.04	-21.26	-152.36	-147.89	-25.73	23.81
		64	1.41	1.55	-0.58	1.45	-0.48	0.46	-47.98	-160.03	-150.82	-57.18	30.77
		65	0.35	1.72	0.05	1.50	0.26	-0.56	17.41	-17.90	9.10	-9.59	-14.98
45	57	27	0.22	1.28	0.16	1.24	0.20	-0.20	4.85	-17.50	1.54	-14.20	-7.93
		24	1.36	1.13	-0.26	1.13	-0.26	0.09	-21.44	-146.90	-142.39	-25.95	23.35
		64	1.36	1.50	-0.64	1.37	-0.52	0.51	-48.10	-155.75	-146.43	-57.42	30.28
		65	0.33	1.69	0.04	1.43	0.29	-0.59	19.41	-13.22	13.81	-7.62	-12.31
46	1	5	0.98	1.14	-0.03	1.12	-0.01	-0.15	-32.65	-111.73	-91.82	-52.56	-34.32
		27	0.25	1.27	-0.05	1.27	-0.05	0.02	-4.13	-27.00	-12.37	-18.76	-10.98
		65	0.19	1.59	-0.08	1.51	-2.27e-03	0.35	-4.44	-19.79	-5.76	-18.47	-4.30
		60	1.16	1.26	-0.41	0.95	-0.10	-0.65	-70.21	-138.37	-100.79	-107.78	-33.90
46	2	5	0.70	0.81	-0.02	0.80	-0.01	-0.10	-22.82	-79.53	-65.10	-37.25	-24.70
		27	0.18	0.91	-0.03	0.91	-0.03	0.01	-2.43	-19.18	-8.84	-12.76	-8.14
		65	0.12	1.14	-0.05	1.09	3.13e-03	0.24	-2.88	-13.09	-4.10	-11.87	-3.32
		60	0.83	0.89	-0.29	0.67	-0.07	-0.46	-49.55	-98.38	-71.41	-76.52	-24.28
46	24	5	0.90	1.12	0.16	1.10	0.18	-0.15	-31.75	-104.98	-61.93	-74.81	-36.04
		27	0.47	1.22	-0.15	1.19	-0.12	-0.22	18.62	-33.96	-0.42	-14.91	-25.27
		65	0.34	1.23	-0.11	1.23	-0.11	-5.16e-03	14.01	-24.21	3.02	-13.22	-17.30
		60	1.13	1.07	-0.18	0.80	0.09	-0.52	-51.87	-133.58	-70.73	-114.73	-34.43
46	66	5	0.78	0.96	0.02	0.93	0.05	-0.15	-29.90	-90.07	-69.79	-50.17	-28.44
		27	0.33	1.06	-0.06	1.06	-0.06	-0.06	4.47	-31.05	-12.85	-13.73	-17.75
		65	0.24	1.25	-0.05	1.22	-0.02	0.17	0.76	-21.93	-9.16	-12.02	-11.26
		60	0.95	1.02	-0.29	0.75	-0.02	-0.53	-55.35	-113.15	-78.60	-89.91	-28.34
47	1	22	1.18	0.70	-0.07	0.70	-0.07	-0.01	-20.02	-128.29	-127.82	-20.49	7.09
		25	0.65	0.73	0.06	0.73	0.06	0.02	-28.50	-75.06	-70.88	-32.68	13.32
		62	0.63	0.88	0.05	0.83	0.10	0.20	-47.98	-72.26	-64.94	-55.30	11.14
		63	1.25	0.99	-0.22	0.97	-0.20	-0.16	-42.79	-142.17	-142.16	-42.80	1.03
47	2	22	0.87	0.51	-0.05	0.51	-0.05	-2.98e-03	-14.51	-94.60	-94.32	-14.79	4.66
		25	0.48	0.52	0.04	0.52	0.04	0.01	-20.25	-54.57	-51.49	-23.33	9.80
		62	0.45	0.63	0.03	0.60	0.07	0.14	-34.01	-52.19	-46.97	-39.23	8.23
		63	0.92	0.71	-0.15	0.70	-0.14	-0.11	-30.56	-104.38	-104.38	-30.56	0.26
47	8	22	1.16	0.49	-0.17	0.49	-0.17	0.04	-12.86	-124.82	-124.76	-12.92	2.56
		25	0.72	0.61	0.18	0.57	0.23	0.13	-25.11	-82.47	-75.81	-31.77	18.37
		62	0.63	0.87	0.11	0.72	0.27	0.30	-37.33	-74.58	-65.40	-46.50	16.05
		63	1.17	0.76	-0.24	0.76	-0.24	-0.05	-27.70	-129.87	-129.76	-27.80	-3.23
47	40	22	1.07	0.52	-0.09	0.52	-0.09	0.02	-14.24	-115.33	-115.20	-14.36	3.51
		25	0.61	0.57	0.11	0.57	0.12	0.06	-22.20	-69.69	-64.99	-26.90	14.19
		62	0.55	0.76	0.08	0.68	0.16	0.22	-35.31	-64.35	-57.44	-42.22	12.37
		63	1.10	0.76	-0.18	0.76	-0.17	-0.08	-29.78	-123.09	-123.06	-29.81	-1.69
48	1	7	0.72	0.36	0.05	0.26	0.15	0.15	-14.75	-81.51	-60.75	-35.51	30.90
		43	0.69	0.54	0.02	0.52	0.04	-0.09	-19.37	-77.09	-73.13	-23.32	14.59
		59	1.07	0.39	-0.42	0.19	-0.21	0.36	-53.32	-126.55	-71.94	-107.93	31.89
		61	0.69	0.62	0.29	0.62	0.29	-4.15e-03	-41.40	-81.07	-58.36	-64.11	19.62
48	2	7	0.52	0.26	0.04	0.18	0.11	0.10	-9.67	-58.74	-43.35	-25.05	22.76
		43	0.50	0.38	0.02	0.37	0.03	-0.07	-13.38	-55.41	-52.33	-16.46	10.96
		59	0.77	0.28	-0.30	0.13	-0.15	0.25	-36.42	-90.38	-50.56	-76.24	23.72
		61	0.50	0.44	0.21	0.44	0.21	-3.32e-03	-28.91	-58.37	-41.80	-45.48	14.62

48	31	7	1.07	0.71	0.24	0.56	0.40	0.22	2.77	-110.02	-50.10	-57.15	56.28
		43	3.37	0.76	0.29	0.75	0.29	-0.04	343.44	-14.79	13.90	314.75	97.24
		59	4.93	0.51	-0.14	0.31	0.06	0.30	491.61	-38.58	160.12	292.91	256.64
		61	3.45	0.68	0.42	0.64	0.46	0.10	221.86	-191.05	81.91	-51.10	195.45
48	63	7	0.73	0.46	0.12	0.35	0.23	0.16	-2.24	-76.37	-43.49	-35.12	36.83
		43	1.52	0.55	0.13	0.54	0.14	-0.06	136.72	-35.95	-21.99	122.76	47.07
		59	2.17	0.39	-0.24	0.21	-0.07	0.28	190.41	-56.28	47.14	86.99	121.73
		61	1.58	0.55	0.32	0.54	0.32	0.04	77.08	-111.96	9.49	-44.37	90.60
49	1	47	0.62	-0.13	-0.41	-0.14	-0.41	-0.04	-41.38	-73.03	-41.38	-73.03	-0.02
		66	1.56	1.08	-0.06	0.50	0.53	0.57	-117.72	-184.08	-162.94	-138.85	30.92
		42	0.53	-0.11	-0.39	-0.38	-0.12	-0.05	-37.06	-61.68	-61.59	-37.16	1.50
		4	0.52	0.54	-0.25	0.14	0.14	0.40	-46.03	-59.96	-53.38	-52.62	6.95
49	2	47	0.44	-0.10	-0.30	-0.10	-0.29	-0.03	-29.53	-51.89	-29.54	-51.89	0.24
		66	1.11	0.77	-0.04	0.35	0.38	0.40	-83.11	-131.75	-116.23	-98.63	22.67
		42	0.37	-0.08	-0.28	-0.28	-0.09	-0.03	-26.39	-43.67	-43.57	-26.49	1.32
		4	0.37	0.39	-0.18	0.10	0.10	0.28	-32.27	-43.08	-37.96	-37.39	5.40
49	24	47	2.65	-0.18	-0.50	-0.18	-0.50	-0.01	111.94	-201.99	-74.89	-15.17	154.10
		66	4.96	0.69	-0.17	0.31	0.21	0.43	-95.37	-555.56	-228.78	-422.15	208.79
		42	2.98	-0.29	-0.39	-0.38	-0.30	-0.03	-76.69	-340.96	-83.54	-334.10	42.01
		4	0.30	0.30	-0.33	0.03	-0.07	0.31	20.40	-13.56	-6.60	13.44	13.71
49	56	47	1.15	-0.14	-0.40	-0.14	-0.39	-0.02	24.00	-106.06	-48.43	-33.63	64.60
		66	2.58	0.76	-0.09	0.34	0.32	0.42	-83.98	-299.48	-157.09	-226.36	102.03
		42	1.34	-0.18	-0.34	-0.33	-0.18	-0.03	-53.57	-158.17	-56.90	-154.84	18.35
		4	0.27	0.36	-0.25	0.08	0.03	0.31	-7.19	-29.36	-22.68	-13.87	10.17
50	1	81	0.70	1.07	-0.54	-0.54	1.07	0.04	-29.78	-81.34	-47.02	-64.10	24.32
		95	0.84	1.49	-1.25	-1.06	1.31	-0.69	-50.87	-99.72	-86.24	-64.35	21.84
		68	1.21	1.46	-0.77	0.01	0.67	1.07	-91.84	-141.51	-119.92	-113.43	24.63
		11	0.90	1.11	0.06	0.07	1.10	-0.12	-44.98	-104.16	-55.53	-93.62	22.64
50	2	81	0.50	0.76	-0.38	-0.38	0.76	0.03	-21.10	-58.18	-33.43	-45.86	17.47
		95	0.60	1.07	-0.89	-0.76	0.93	-0.50	-36.13	-70.89	-61.10	-45.92	15.63
		68	0.86	1.03	-0.55	4.40e-03	0.48	0.76	-65.08	-100.89	-85.28	-80.69	17.75
		11	0.65	0.80	0.04	0.05	0.79	-0.09	-31.81	-74.36	-39.48	-66.69	16.36
50	28	81	0.98	0.53	-0.44	-0.42	0.51	0.14	-36.23	-113.58	-48.54	-101.26	28.30
		95	1.26	1.02	-0.85	-0.75	0.92	-0.44	-69.06	-146.85	-83.22	-132.70	30.01
		68	1.36	1.31	-0.93	-0.04	0.42	1.10	-87.43	-162.89	-88.28	-162.04	7.93
		11	1.02	0.60	-0.09	-0.02	0.53	0.21	-37.00	-117.50	-37.03	-117.47	1.64
50	60	81	0.71	0.69	-0.42	-0.42	0.68	0.07	-27.55	-82.25	-39.29	-70.51	22.46
		95	0.87	1.09	-0.90	-0.77	0.95	-0.50	-53.79	-100.57	-70.55	-83.81	22.43
		68	1.02	1.16	-0.73	-0.03	0.46	0.91	-79.13	-120.51	-84.60	-115.03	14.02
		11	0.77	0.71	0.02	0.02	0.71	0.02	-34.98	-89.21	-36.69	-87.50	9.49
51	1	45	0.76	1.00	-0.06	-0.03	0.97	0.17	-37.09	-86.82	-41.64	-82.27	-14.34
		69	1.42	0.52	-1.18	-0.36	-0.30	-0.85	-124.67	-161.52	-161.46	-124.72	-1.38
		70	1.11	0.75	0.36	0.37	0.75	0.01	-73.66	-130.02	-97.32	-106.36	-27.81
		9	0.86	0.69	-0.17	0.14	0.38	-0.41	-54.34	-102.92	-61.77	-95.49	-17.49
51	2	45	0.54	0.71	-0.05	-0.02	0.69	0.12	-26.25	-61.92	-29.72	-58.46	-10.57
		69	1.01	0.37	-0.85	-0.26	-0.22	-0.61	-88.52	-115.23	-115.19	-88.55	-0.98
		70	0.79	0.53	0.25	0.26	0.53	9.79e-03	-51.94	-92.75	-68.93	-75.76	-20.11
		9	0.61	0.49	-0.12	0.10	0.27	-0.29	-38.63	-73.47	-44.01	-68.09	-12.60
51	24	45	2.76	0.51	-0.20	-0.16	0.48	0.15	46.87	-259.88	-132.78	-80.23	151.11
		69	5.40	0.21	-1.07	-0.40	-0.46	-0.64	-140.28	-617.36	-280.06	-477.58	217.13
		70	4.06	0.36	0.08	0.09	0.35	0.03	-97.83	-461.89	-103.67	-456.05	45.75
		9	0.60	0.23	-0.28	-0.06	0.01	-0.25	-4.50	-64.82	-4.51	-64.81	0.64
51	56	45	1.16	0.65	-0.12	-0.09	0.63	0.14	-11.41	-126.04	-72.66	-64.79	57.18
		69	2.61	0.31	-0.98	-0.33	-0.34	-0.64	-113.28	-308.14	-177.89	-243.53	91.73
		70	2.02	0.48	0.18	0.18	0.48	0.02	-80.57	-236.58	-80.90	-236.25	7.14
		9	0.56	0.39	-0.19	0.03	0.17	-0.28	-24.55	-66.11	-25.40	-65.27	-5.87

52	1	83	0.70	1.02	-0.20	-0.09	0.90	0.35	-28.94	-78.76	-46.85	-60.85	-23.91
		87	0.79	1.11	-0.14	-0.03	1.00	0.36	-45.29	-91.87	-78.88	-58.27	-20.89
		67	0.38	1.00	0.30	0.31	1.00	-0.04	-17.22	-44.38	-44.20	-17.40	2.18
		33	0.27	0.83	0.22	0.22	0.83	-0.04	-19.88	-29.97	-29.96	-19.89	0.26
52	2	83	0.50	0.73	-0.15	-0.07	0.64	0.26	-20.36	-56.19	-33.20	-43.36	-17.18
		87	0.56	0.79	-0.10	-0.02	0.71	0.26	-32.03	-65.17	-55.77	-41.43	-14.94
		67	0.27	0.71	0.22	0.23	0.71	-0.03	-12.26	-30.91	-30.78	-12.39	1.55
		33	0.19	0.59	0.16	0.16	0.59	-0.03	-14.26	-21.08	-21.07	-14.27	0.20
52	16	83	0.75	0.87	-0.28	-0.19	0.78	0.31	-29.05	-85.62	-53.61	-61.06	-28.04
		87	0.79	0.89	-0.25	-0.15	0.79	0.32	-36.65	-92.47	-75.51	-53.61	-25.68
		67	0.39	0.86	0.29	0.31	0.84	-0.09	-22.81	-45.40	-45.39	-22.82	0.54
		33	0.35	0.79	0.23	0.25	0.76	-0.12	-30.41	-37.70	-37.42	-30.69	-1.40
52	48	83	0.61	0.81	-0.21	-0.12	0.72	0.29	-23.70	-69.26	-41.28	-51.68	-22.18
		87	0.66	0.86	-0.16	-0.07	0.76	0.29	-33.90	-77.30	-63.79	-47.41	-20.10
		67	0.31	0.80	0.26	0.27	0.80	-0.05	-17.12	-36.63	-36.57	-17.18	1.10
		33	0.26	0.69	0.20	0.21	0.68	-0.07	-21.83	-28.02	-27.97	-21.88	-0.55
53	1	11	0.86	0.69	-0.17	0.14	0.38	0.41	-54.34	-102.92	-61.77	-95.49	17.49
		68	1.11	0.75	0.36	0.37	0.75	-0.01	-73.66	-130.02	-97.32	-106.36	27.81
		66	1.42	0.52	-1.18	-0.36	-0.30	0.85	-124.67	-161.52	-161.46	-124.72	1.38
		47	0.76	1.00	-0.06	-0.03	0.97	-0.17	-37.09	-86.82	-41.64	-82.27	14.34
53	2	11	0.61	0.49	-0.12	0.10	0.27	0.29	-38.63	-73.47	-44.01	-68.09	12.60
		68	0.79	0.53	0.25	0.26	0.53	-9.79e-03	-51.94	-92.75	-68.93	-75.76	20.11
		66	1.01	0.37	-0.85	-0.26	-0.22	0.61	-88.52	-115.23	-115.19	-88.55	0.98
		47	0.54	0.71	-0.05	-0.02	0.69	-0.12	-26.25	-61.92	-29.72	-58.46	10.57
53	22	11	0.60	0.23	-0.28	-0.06	0.01	0.25	-4.50	-64.82	-4.51	-64.81	-0.64
		68	4.06	0.36	0.08	0.09	0.35	-0.03	-97.83	-461.89	-103.67	-456.05	-45.75
		66	5.40	0.21	-1.07	-0.40	-0.46	0.64	-140.28	-617.36	-280.06	-477.58	-217.13
		47	2.76	0.51	-0.20	-0.16	0.48	-0.15	46.87	-259.88	-132.78	-80.23	-151.11
53	54	11	0.56	0.39	-0.19	0.03	0.17	0.28	-24.55	-66.11	-25.40	-65.27	5.87
		68	2.02	0.48	0.18	0.18	0.48	-0.02	-80.57	-236.58	-80.90	-236.25	-7.14
		66	2.61	0.31	-0.98	-0.33	-0.34	0.64	-113.28	-308.14	-177.89	-243.53	-91.73
		47	1.16	0.65	-0.12	-0.09	0.63	-0.14	-11.41	-126.04	-72.66	-64.79	-57.18
54	1	1	0.52	0.54	-0.25	0.14	0.14	-0.40	-46.03	-59.96	-53.38	-52.62	-6.95
		41	0.53	-0.11	-0.39	-0.38	-0.12	0.05	-37.06	-61.68	-61.59	-37.16	-1.50
		69	1.56	1.08	-0.06	0.50	0.53	-0.57	-117.72	-184.08	-162.94	-138.85	-30.92
		45	0.62	-0.13	-0.41	-0.14	-0.41	0.04	-41.38	-73.03	-41.38	-73.03	0.02
54	2	1	0.37	0.39	-0.18	0.10	0.10	-0.28	-32.27	-43.08	-37.96	-37.39	-5.40
		41	0.37	-0.08	-0.28	-0.28	-0.09	0.03	-26.39	-43.67	-43.57	-26.49	-1.32
		69	1.11	0.77	-0.04	0.35	0.38	-0.40	-83.11	-131.75	-116.23	-98.63	-22.67
		45	0.44	-0.10	-0.30	-0.10	-0.29	0.03	-29.53	-51.89	-29.54	-51.89	-0.24
54	22	1	0.30	0.30	-0.33	0.03	-0.07	-0.31	20.40	-13.56	-6.60	13.44	-13.71
		41	2.98	-0.29	-0.39	-0.38	-0.30	0.03	-76.69	-340.96	-83.54	-334.10	-42.01
		69	4.96	0.69	-0.17	0.31	0.21	-0.43	-95.37	-555.56	-228.78	-422.15	-208.79
		45	2.65	-0.18	-0.50	-0.18	-0.50	0.01	111.94	-201.99	-74.89	-15.17	-154.10
54	54	1	0.27	0.36	-0.25	0.08	0.03	-0.31	-7.19	-29.36	-22.68	-13.87	-10.17
		41	1.34	-0.18	-0.34	-0.33	-0.18	0.03	-53.57	-158.17	-56.90	-154.84	-18.35
		69	2.58	0.76	-0.09	0.34	0.32	-0.42	-83.98	-299.48	-157.09	-226.36	-102.03
		45	1.15	-0.14	-0.40	-0.14	-0.39	0.02	24.00	-106.06	-48.43	-33.63	-64.60
55	1	127	7.23	2.92	-9.81	-7.39	0.50	-5.00	20.80	-4.46	-4.11	20.45	-2.94
		110	8.10	1.32	-16.72	-7.75	-7.65	-9.02	29.74	3.43	3.54	29.63	-1.70
		96	17.65	0.04	-24.69	0.02	-24.67	-0.81	5.46	-50.14	5.42	-50.10	1.48
		97	12.50	14.91	8.06	8.14	14.83	0.74	-5.83	-44.99	-5.97	-44.84	2.38
55	2	127	5.05	2.26	-6.86	-5.31	0.71	-3.43	14.12	-3.19	-2.93	13.85	-2.12
		110	5.72	1.19	-12.04	-5.48	-5.37	-6.62	20.94	2.48	2.56	20.86	-1.21
		96	12.46	2.47e-03	-17.42	-0.01	-17.41	-0.49	3.96	-35.34	3.93	-35.31	1.04
		97	8.77	10.88	5.84	5.86	10.86	0.33	-4.19	-31.25	-4.30	-31.14	1.71

55	19	127	4.70	2.50	-7.76	-6.17	0.91	-3.71	11.72	-3.23	-3.08	11.57	-1.46
		110	5.15	1.24	-13.31	-6.11	-5.96	-7.27	16.77	2.52	2.53	16.76	-0.41
		96	14.63	0.93	-19.00	0.92	-18.98	-0.53	4.36	-42.40	4.36	-42.40	0.17
		97	9.35	11.69	7.40	7.40	11.69	-0.06	-4.38	-33.42	-4.40	-33.40	0.73
55	51	127	4.98	2.63	-7.49	-5.91	1.05	-3.67	13.01	-3.25	-3.04	12.80	-1.83
		110	5.68	1.40	-13.07	-5.85	-5.82	-7.24	19.83	2.53	2.57	19.79	-0.85
		96	13.79	0.33	-18.85	0.32	-18.83	-0.50	4.26	-39.39	4.25	-39.38	0.62
		97	9.13	11.84	6.80	6.80	11.84	-0.03	-4.45	-32.22	-4.50	-32.17	1.26
56	1	126	7.23	2.92	-9.81	-7.39	0.50	-5.00	4.46	-20.80	4.11	-20.45	2.94
		111	8.10	1.32	-16.72	-7.75	-7.65	-9.02	-3.43	-29.74	-3.54	-29.63	1.70
		88	17.65	0.04	-24.69	0.02	-24.67	-0.81	50.14	-5.46	-5.42	50.10	-1.48
		89	12.50	14.91	8.06	8.14	14.83	0.74	44.99	5.83	5.97	44.84	-2.38
56	2	126	5.05	2.26	-6.86	-5.31	0.71	-3.43	3.19	-14.12	2.93	-13.85	2.12
		111	5.72	1.19	-12.04	-5.48	-5.37	-6.62	-2.48	-20.94	-2.56	-20.86	1.21
		88	12.46	2.47e-03	-17.42	-0.01	-17.41	-0.49	35.34	-3.96	-3.93	35.31	-1.04
		89	8.77	10.88	5.84	5.86	10.86	0.33	31.25	4.19	4.30	31.14	-1.71
56	25	126	4.70	2.50	-7.76	-6.17	0.91	-3.71	3.23	-11.72	3.08	-11.57	1.46
		111	5.15	1.24	-13.31	-6.11	-5.96	-7.27	-2.52	-16.77	-2.53	-16.76	0.41
		88	14.63	0.93	-19.00	0.92	-18.98	-0.53	42.40	-4.36	-4.36	42.40	-0.17
		89	9.35	11.69	7.40	7.40	11.69	-0.06	33.42	4.38	4.40	33.40	-0.73
56	57	126	4.98	2.63	-7.49	-5.91	1.05	-3.67	3.25	-13.01	3.04	-12.80	1.83
		111	5.68	1.40	-13.07	-5.85	-5.82	-7.24	-2.53	-19.83	-2.57	-19.79	0.85
		88	13.79	0.33	-18.85	0.32	-18.83	-0.50	39.39	-4.26	-4.25	39.38	-0.62
		89	9.13	11.84	6.80	6.80	11.84	-0.03	32.22	4.45	4.50	32.17	-1.26
57	1	125	3.29	5.62	-6.28	-4.33	3.67	4.41	1.26	-4.93	1.05	-4.71	-1.14
		109	4.63	3.14	-4.93	2.53	-4.33	-2.13	14.12	-1.02	-0.88	13.99	-1.44
		75	2.75	1.74	-2.97	-1.99	0.76	1.91	0.33	-9.74	0.26	-9.68	0.81
		131	1.45	1.82	-1.82	0.71	-0.70	-1.68	3.98	-0.45	-0.40	3.93	0.50
57	2	125	2.42	3.77	-4.39	-3.05	2.44	3.02	0.83	-4.22	0.67	-4.06	-0.88
		109	3.30	2.22	-3.46	1.77	-3.01	-1.53	10.24	-0.67	-0.54	10.11	-1.19
		75	1.99	1.18	-2.01	-1.38	0.54	1.27	0.35	-7.09	0.28	-7.02	0.71
		131	1.12	1.33	-1.23	0.59	-0.49	-1.16	3.10	-0.45	-0.39	3.05	0.42
57	29	125	2.71	3.81	-4.66	-3.19	2.35	3.20	0.83	-5.16	0.45	-4.79	-1.44
		109	4.01	2.26	-3.56	1.76	-3.07	-1.62	13.22	-0.89	-0.64	12.97	-1.85
		75	1.78	1.29	-2.05	-1.40	0.64	1.32	0.66	-6.19	0.42	-5.95	1.26
		131	1.40	1.35	-1.06	0.75	-0.45	-1.04	4.17	-0.68	-0.55	4.05	0.77
57	61	125	2.68	3.73	-4.59	-3.17	2.32	3.12	0.80	-5.30	0.55	-5.05	-1.20
		109	3.75	2.32	-3.64	1.78	-3.11	-1.70	12.12	-0.76	-0.54	11.90	-1.65
		75	2.02	1.21	-1.98	-1.38	0.61	1.24	0.56	-7.17	0.41	-7.02	1.07
		131	1.34	1.43	-1.15	0.77	-0.49	-1.13	3.88	-0.64	-0.56	3.79	0.63
58	1	123	2.24	5.80	-5.89	-3.93	3.84	4.36	-0.46	-1.69	-1.11	-1.04	0.61
		110	3.64	3.48	-4.79	2.87	-4.18	-2.16	1.16	-9.21	1.16	-9.21	-0.18
		72	2.03	1.98	-3.71	-2.36	0.62	2.42	6.04	0.32	0.33	6.03	0.24
		130	0.78	1.83	-2.00	0.41	-0.58	-1.85	-0.30	-1.09	-0.32	-1.07	-0.11
58	2	123	1.61	3.91	-4.09	-2.76	2.59	2.98	0.04	-1.03	-0.71	-0.27	0.49
		110	2.54	2.46	-3.34	2.02	-2.90	-1.54	0.75	-6.49	0.75	-6.49	-0.02
		72	1.42	1.35	-2.56	-1.65	0.44	1.65	4.26	0.16	0.17	4.26	0.09
		130	0.59	1.32	-1.36	0.36	-0.40	-1.28	-0.12	-0.92	-0.14	-0.90	-0.13
58	15	123	1.52	3.99	-3.98	-2.64	2.65	2.98	-0.34	-1.67	-0.69	-1.33	0.58
		110	3.03	2.88	-3.54	2.39	-3.05	-1.70	0.73	-8.29	0.73	-8.29	0.10
		72	1.17	1.29	-2.75	-1.95	0.48	1.62	2.88	0.15	0.15	2.88	0.05
		130	0.86	1.35	-1.52	0.24	-0.40	-1.40	-0.06	-2.34	-0.07	-2.33	-0.16
58	47	123	1.61	3.98	-4.14	-2.80	2.64	3.02	-0.06	-1.18	-0.69	-0.55	0.56
		110	2.80	2.72	-3.54	2.24	-3.06	-1.67	0.73	-7.39	0.73	-7.39	0.07
		72	1.34	1.34	-2.69	-1.82	0.48	1.66	3.78	0.14	0.14	3.78	0.04
		130	0.73	1.39	-1.44	0.36	-0.41	-1.36	-0.07	-1.58	-0.09	-1.56	-0.16

59	1	132	0.62	0.32	0.09	0.32	0.09	0.03	1.08	-1.84	-0.20	-0.55	1.45
		130	0.69	-0.34	-1.22	-0.85	-0.71	0.44	2.30	1.05	1.57	1.79	-0.62
		72	0.93	2.08	0.48	1.19	1.36	-0.79	-1.99	-3.42	-2.23	-3.17	-0.54
		129	0.70	-0.55	-1.41	-1.02	-0.94	0.43	2.21	0.56	0.80	1.97	-0.58
59	2	132	0.43	0.26	0.04	0.25	0.04	0.03	0.73	-1.27	-0.15	-0.39	0.99
		130	0.47	-0.20	-0.83	-0.58	-0.45	0.31	1.59	0.75	1.07	1.27	-0.41
		72	0.66	1.45	0.35	0.83	0.96	-0.55	-1.38	-2.40	-1.55	-2.24	-0.38
		129	0.47	-0.42	-1.00	-0.76	-0.65	0.29	1.49	0.37	0.51	1.35	-0.38
59	19	132	1.00	0.56	-0.08	0.37	0.10	-0.29	1.16	-3.08	-0.31	-1.61	2.02
		130	0.79	-0.14	-0.55	-0.53	-0.15	0.08	0.91	-2.51	0.91	-2.51	0.01
		72	1.54	1.91	0.39	1.03	1.28	-0.75	-2.47	-6.65	-2.93	-6.19	-1.31
		129	0.42	-0.57	-0.73	-0.71	-0.60	0.06	0.47	-1.26	-0.97	0.18	-0.65
59	51	132	0.66	0.37	0.02	0.34	0.05	-0.10	0.91	-2.03	-0.22	-0.90	1.43
		130	0.40	-0.18	-0.69	-0.57	-0.30	0.22	1.04	-0.31	1.01	-0.27	-0.23
		72	1.03	1.68	0.38	0.93	1.13	-0.64	-1.83	-4.24	-2.12	-3.95	-0.79
		129	0.40	-0.52	-0.93	-0.80	-0.65	0.19	1.07	-0.34	-0.15	0.88	-0.48
60	1	121	1.50	1.22	-1.40	0.45	-0.63	1.20	-0.45	-6.05	-0.66	-5.84	-1.06
		106	5.84	3.25	-5.78	1.54	-4.07	-3.54	5.13	-17.23	5.00	-17.10	1.70
		76	3.28	1.76	-4.65	-2.70	-0.20	2.95	13.60	6.08	6.39	13.29	-1.51
		135	1.71	0.20	-1.35	-1.22	0.07	-0.43	3.80	-3.71	-3.28	3.37	1.74
60	2	121	1.06	0.82	-0.99	0.36	-0.53	0.79	-0.46	-4.13	-0.52	-4.06	-0.48
		106	4.19	2.37	-4.08	1.10	-2.81	-2.56	3.41	-12.63	3.31	-12.54	1.22
		76	2.36	1.23	-3.24	-1.89	-0.12	2.05	9.95	4.10	4.31	9.75	-1.08
		135	1.21	0.18	-0.94	-0.84	0.09	-0.32	2.63	-2.60	-2.41	2.44	0.98
60	12	121	1.28	0.57	-0.66	0.42	-0.51	0.41	-0.11	-4.58	-0.73	-3.96	1.55
		106	5.10	2.91	-4.45	1.14	-2.68	-3.15	3.69	-17.06	3.22	-16.59	3.10
		76	2.58	1.16	-2.87	-1.89	0.17	1.73	10.15	2.82	4.37	8.60	-3.00
		135	1.50	0.68	-1.03	-0.74	0.40	-0.64	3.05	-2.85	-2.64	2.83	-1.10
60	44	121	1.15	0.64	-0.89	0.40	-0.65	0.56	-0.60	-4.17	-0.69	-4.09	0.54
		106	4.79	2.74	-4.43	1.12	-2.82	-2.99	3.49	-15.40	3.26	-15.16	2.08
		76	2.55	1.19	-3.05	-1.90	0.03	1.89	10.62	3.75	4.35	10.02	-1.93
		135	1.30	0.45	-0.95	-0.76	0.26	-0.49	2.70	-2.66	-2.66	2.70	-0.03
61	1	113	9.80	-0.41	-8.00	-7.35	-1.06	-2.12	4.41	-34.90	4.15	-34.64	3.22
		104	8.19	4.83	-19.68	-10.51	-4.34	-11.86	-5.75	-23.95	-7.07	-22.63	-4.73
		18	12.98	1.88	-21.88	1.73	-21.73	-1.86	30.79	-7.53	-6.90	30.16	4.87
		30	11.61	22.40	6.34	9.07	19.67	6.03	36.86	3.72	3.99	36.59	-2.99
61	2	113	6.81	-0.05	-5.67	-5.32	-0.40	-1.36	3.46	-23.57	3.22	-23.34	2.53
		104	5.83	3.63	-14.30	-7.60	-3.07	-8.67	-4.45	-16.84	-5.35	-15.94	-3.22
		18	9.18	1.35	-15.35	1.26	-15.25	-1.24	21.65	-5.63	-5.22	21.24	3.33
		30	8.18	16.29	4.65	6.53	14.42	4.28	25.72	2.85	3.09	25.47	-2.36
61	28	113	7.21	0.40	-6.41	-5.95	-0.07	-1.71	4.07	-24.07	3.78	-23.78	2.84
		104	6.47	4.70	-16.63	-8.48	-3.44	-10.37	-4.95	-16.78	-6.24	-15.48	-3.69
		18	9.69	1.68	-15.90	1.48	-15.71	-1.83	22.56	-6.58	-5.97	21.95	4.18
		30	8.25	17.60	5.62	7.30	15.91	4.16	25.10	3.29	3.53	24.85	-2.30
61	60	113	7.13	0.37	-6.21	-5.90	0.06	-1.41	4.08	-23.79	3.78	-23.48	2.90
		104	6.39	4.50	-16.25	-8.43	-3.32	-10.06	-5.03	-17.08	-6.25	-15.86	-3.63
		18	9.53	1.61	-15.72	1.48	-15.59	-1.52	22.11	-6.51	-5.97	21.57	3.90
		30	8.35	17.92	5.42	7.30	16.04	4.47	25.46	3.22	3.53	25.15	-2.58
62	1	120	1.92	0.96	-0.91	0.26	-0.21	0.91	6.75	-1.12	-0.25	5.88	2.47
		107	3.51	3.32	-5.46	1.63	-3.77	-3.46	6.97	-4.99	-4.91	6.90	-0.94
		79	2.40	1.88	-4.90	-2.76	-0.26	3.15	-4.28	-7.07	-6.60	-4.75	1.04
		139	1.66	-0.04	-1.27	-1.07	-0.24	-0.46	3.20	-4.52	1.95	-3.28	-2.84
62	2	120	1.26	0.62	-0.61	0.22	-0.21	0.58	4.60	-0.66	-0.15	4.09	1.54
		107	2.45	2.41	-3.82	1.18	-2.59	-2.47	4.96	-3.30	-3.25	4.91	-0.65
		79	1.66	1.32	-3.45	-1.95	-0.18	2.22	-3.00	-4.83	-4.47	-3.37	0.73
		139	1.12	-0.01	-0.88	-0.74	-0.15	-0.32	2.15	-3.09	1.43	-2.36	-1.81

62	8	120	1.66	1.25	-0.27	1.10	-0.12	0.45	6.08	-0.33	-0.33	6.08	-0.03
		107	3.36	3.36	-3.87	2.09	-2.60	-2.75	8.95	-3.77	-3.38	8.57	-2.18
		79	2.25	1.28	-3.73	-2.49	0.04	2.16	1.07	-5.16	-4.46	0.36	1.97
		139	0.71	0.18	-1.36	-1.22	0.04	-0.45	1.69	-0.79	1.54	-0.63	-0.60
62	40	120	1.35	0.85	-0.48	0.61	-0.23	0.51	5.13	-0.37	-0.23	4.99	0.86
		107	2.84	2.89	-4.00	1.59	-2.71	-2.69	6.60	-3.46	-3.29	6.43	-1.31
		79	1.87	1.32	-3.60	-2.22	-0.07	2.22	-1.27	-4.99	-4.50	-1.77	1.27
		139	0.91	0.07	-1.09	-0.94	-0.08	-0.39	1.95	-2.17	1.50	-1.72	-1.29
63	1	112	9.80	-0.41	-8.00	-7.35	-1.06	-2.12	34.90	-4.41	-4.15	34.64	-3.22
		106	8.19	4.83	-19.68	-10.51	-4.34	-11.86	23.95	5.75	7.07	22.63	4.73
		17	12.98	1.88	-21.88	1.73	-21.73	-1.86	7.53	-30.79	6.90	-30.16	-4.87
		29	11.61	22.40	6.34	9.07	19.67	6.03	-3.72	-36.86	-3.99	-36.59	2.99
63	2	112	6.81	-0.05	-5.67	-5.32	-0.40	-1.36	23.57	-3.46	-3.22	23.34	-2.53
		106	5.83	3.63	-14.30	-7.60	-3.07	-8.67	16.84	4.45	5.35	15.94	3.22
		17	9.18	1.35	-15.35	1.26	-15.25	-1.24	5.63	-21.65	5.22	-21.24	-3.33
		29	8.18	16.29	4.65	6.53	14.42	4.28	-2.85	-25.72	-3.09	-25.47	2.36
63	34	112	7.21	0.40	-6.41	-5.95	-0.07	-1.71	24.07	-4.07	-3.78	23.78	-2.84
		106	6.47	4.70	-16.63	-8.48	-3.44	-10.37	16.78	4.95	6.24	15.48	3.69
		17	9.69	1.68	-15.90	1.48	-15.71	-1.83	6.58	-22.56	5.97	-21.95	-4.18
		29	8.25	17.60	5.62	7.30	15.91	4.16	-3.29	-25.10	-3.53	-24.85	2.30
63	66	112	7.13	0.37	-6.21	-5.90	0.06	-1.41	23.79	-4.08	-3.78	23.48	-2.90
		106	6.39	4.50	-16.25	-8.43	-3.32	-10.06	17.08	5.03	6.25	15.86	3.63
		17	9.53	1.61	-15.72	1.48	-15.59	-1.52	6.51	-22.11	5.97	-21.57	-3.90
		29	8.35	17.92	5.42	7.30	16.04	4.47	-3.22	-25.46	-3.53	-25.15	2.58
64	1	141	1.16	3.74e-03	-1.20	2.10e-03	-1.20	-0.04	2.75	-2.23	1.76	-1.25	1.98
		135	1.48	1.40	-0.11	0.18	1.11	0.60	4.04	-2.67	-2.23	3.60	-1.65
		76	2.96	3.77	0.75	2.41	2.11	-1.51	-7.71	-12.31	-8.01	-12.02	-1.13
		137	2.54	-1.46	-2.58	-2.48	-1.56	0.33	10.54	4.48	5.62	9.39	-2.37
64	2	141	0.83	4.62e-03	-0.84	1.90e-03	-0.84	-0.05	1.93	-1.65	1.22	-0.94	1.43
		135	1.04	1.02	-0.09	0.13	0.80	0.44	2.80	-1.90	-1.61	2.51	-1.13
		76	2.11	2.68	0.52	1.73	1.47	-1.07	-5.69	-8.71	-5.87	-8.53	-0.72
		137	1.78	-1.01	-1.85	-1.79	-1.08	0.23	7.37	3.26	4.13	6.50	-1.68
64	8	141	1.31	-0.03	-0.92	-0.16	-0.79	-0.32	2.33	-3.69	0.76	-2.12	2.64
		135	1.78	1.13	-0.26	-5.14e-03	0.88	0.53	4.16	-3.98	-2.16	2.35	-3.39
		76	2.62	2.83	0.48	1.83	1.48	-1.16	-6.39	-11.81	-9.38	-8.82	-2.69
		137	1.31	-0.98	-2.07	-2.07	-0.98	-0.02	5.45	1.96	2.05	5.37	-0.54
64	56	141	0.98	-0.02	-0.92	-0.05	-0.89	-0.17	2.25	-2.22	1.23	-1.21	1.88
		135	1.09	1.17	-0.11	0.10	0.96	0.48	2.70	-2.38	-1.69	2.01	-1.74
		76	2.34	2.92	0.46	1.83	1.55	-1.22	-6.71	-9.78	-7.33	-9.16	-1.23
		137	1.72	-1.05	-2.09	-2.07	-1.07	0.16	7.04	3.34	4.10	6.28	-1.49
65	1	58	0.81	1.45	-0.70	0.85	-0.09	0.97	-72.33	-92.48	-82.72	-82.08	10.07
		10	0.74	0.80	-0.50	0.04	0.26	0.64	-41.70	-87.38	-47.25	-81.83	14.92
		84	0.91	1.17	-0.56	-0.40	1.00	0.51	-35.70	-104.37	-40.15	-99.92	16.91
		85	1.12	1.08	-1.56	-1.14	0.66	0.97	-78.16	-131.97	-85.50	-124.63	18.46
65	2	58	0.58	1.03	-0.50	0.60	-0.07	0.69	-50.60	-66.42	-58.96	-58.06	7.90
		10	0.53	0.57	-0.36	0.03	0.18	0.46	-29.28	-62.33	-33.69	-57.92	11.24
		84	0.65	0.83	-0.40	-0.29	0.71	0.36	-25.44	-74.28	-28.85	-70.88	12.45
		85	0.79	0.77	-1.11	-0.81	0.47	0.69	-55.44	-93.80	-61.09	-88.15	13.59
65	25	58	1.27	1.37	-1.14	0.59	-0.36	1.16	-60.30	-149.47	-60.34	-149.44	-1.85
		10	1.00	0.74	-1.11	-0.06	-0.30	0.92	-30.23	-114.95	-30.48	-114.70	-4.52
		84	1.24	0.66	-0.77	-0.38	0.27	0.64	-42.88	-144.53	-48.88	-138.53	23.96
		85	1.68	0.78	-1.47	-0.91	0.21	0.98	-81.23	-199.45	-89.33	-191.35	29.87
65	57	58	0.81	1.21	-0.79	0.62	-0.20	0.91	-56.25	-95.12	-56.73	-94.63	4.33
		10	0.68	0.66	-0.68	-9.68e-03	-0.01	0.67	-30.20	-80.50	-30.54	-80.17	4.08
		84	0.91	0.77	-0.56	-0.34	0.55	0.49	-32.34	-105.66	-36.84	-101.16	17.60
		85	1.18	0.79	-1.31	-0.90	0.38	0.83	-66.91	-140.68	-73.56	-134.03	21.13

66	1	70	1.19	0.72	-1.95	-1.59	0.37	-0.90	-93.09	-134.96	-106.55	-121.51	-19.55
		14	2.22	2.00	-2.97	-2.12	1.16	-1.87	-107.50	-251.97	-230.10	-129.37	-51.78
		86	1.12	1.55	-1.33	-1.10	1.32	0.79	-53.43	-128.16	-128.05	-53.55	2.91
		87	0.92	1.56	-0.22	-0.05	1.39	0.52	-47.61	-107.44	-92.20	-62.85	-26.07
66	2	70	0.84	0.51	-1.39	-1.14	0.27	-0.64	-65.94	-96.18	-75.70	-86.42	-14.14
		14	1.58	1.42	-2.12	-1.52	0.82	-1.33	-76.20	-179.34	-163.69	-91.85	-37.00
		86	0.79	1.11	-0.95	-0.78	0.94	0.57	-37.94	-90.46	-90.37	-38.03	2.17
		87	0.66	1.11	-0.16	-0.03	0.99	0.37	-33.83	-76.41	-65.38	-44.86	-18.66
66	34	70	1.84	0.60	-2.41	-1.89	0.08	-1.14	-50.74	-207.03	-87.87	-169.90	-66.51
		14	2.27	1.76	-3.00	-2.25	1.01	-1.73	-49.78	-243.41	-173.81	-119.38	-92.91
		86	0.86	1.48	-0.84	-0.69	1.33	0.57	-64.35	-100.20	-99.57	-64.98	-4.70
		87	1.22	1.01	-0.08	-0.02	0.96	0.25	-74.80	-142.93	-86.45	-131.28	-25.66
66	66	70	1.23	0.55	-1.86	-1.50	0.20	-0.86	-57.61	-142.45	-78.33	-121.73	-36.45
		14	1.88	1.57	-2.58	-1.91	0.91	-1.53	-67.46	-208.71	-171.18	-104.99	-62.39
		86	0.81	1.31	-0.91	-0.74	1.14	0.59	-50.10	-94.85	-94.82	-50.12	-1.10
		87	0.88	1.10	-0.13	-0.02	1.00	0.34	-55.79	-101.52	-74.67	-82.65	-22.51
67	1	32	0.85	1.10	-8.67e-03	1.09	-2.53e-03	0.08	-48.13	-101.39	-60.83	-88.69	22.69
		16	0.84	0.62	-0.43	0.54	-0.35	0.28	-53.48	-100.50	-88.88	-65.09	20.28
		88	1.85	2.02	-2.61	1.43	-2.02	1.54	-101.06	-210.23	-112.51	-198.78	33.45
		89	0.61	2.05	0.44	1.77	0.73	-0.61	-35.43	-70.20	-35.52	-70.11	-1.77
67	2	32	0.61	0.79	-5.58e-03	0.78	-3.24e-04	0.06	-34.13	-72.25	-43.81	-62.57	16.59
		16	0.60	0.44	-0.30	0.38	-0.25	0.20	-37.01	-72.03	-63.19	-45.84	15.21
		88	1.31	1.44	-1.85	1.01	-1.42	1.11	-71.11	-148.63	-79.64	-140.09	24.26
		89	0.41	1.46	0.32	1.27	0.51	-0.42	-25.00	-47.17	-25.05	-47.12	-1.11
67	25	32	0.95	0.99	-0.17	0.90	-0.08	0.31	-34.88	-110.82	-65.87	-79.83	37.32
		16	1.27	0.59	-0.84	0.40	-0.66	0.48	-53.97	-146.90	-89.97	-110.90	45.27
		88	2.03	1.59	-2.44	1.04	-1.90	1.38	-84.59	-228.83	-99.11	-214.31	43.40
		89	0.53	1.51	0.43	1.46	0.48	-0.24	-30.63	-60.22	-32.79	-58.06	7.70
67	57	32	0.76	0.90	-0.06	0.87	-0.03	0.17	-35.23	-90.83	-55.95	-70.11	26.88
		16	0.87	0.52	-0.54	0.41	-0.43	0.32	-42.43	-102.41	-74.04	-70.80	29.94
		88	1.65	1.54	-2.17	1.04	-1.67	1.26	-77.46	-187.27	-89.35	-175.38	34.12
		89	0.45	1.53	0.41	1.42	0.52	-0.34	-28.53	-50.10	-29.08	-49.55	3.40
68	1	18	2.52	1.85	-2.41	-1.90	1.34	1.39	-129.84	-292.27	-288.34	-133.77	24.97
		20	1.13	1.96	-0.78	1.48	-0.29	-1.05	-44.79	-126.12	-124.79	-46.12	10.32
		90	1.86	1.06	-1.75	-0.35	-0.34	-1.41	-159.02	-213.15	-212.67	-159.51	-5.08
		91	2.01	2.19	-1.22	-1.21	2.17	0.26	-52.89	-222.39	-218.91	-56.37	24.04
68	2	18	1.83	1.31	-1.73	-1.36	0.94	0.99	-92.60	-212.37	-209.77	-95.20	17.45
		20	0.83	1.41	-0.54	1.07	-0.20	-0.74	-31.96	-92.90	-92.11	-32.74	6.86
		90	1.35	0.76	-1.23	-0.24	-0.24	-0.99	-112.17	-155.47	-155.12	-112.53	-3.90
		91	1.46	1.54	-0.90	-0.88	1.53	0.17	-38.89	-162.35	-160.06	-41.18	16.66
68	6	18	2.10	1.32	-1.82	-1.47	0.96	0.99	-98.04	-242.95	-239.53	-101.46	22.00
		20	1.00	1.55	-0.82	1.14	-0.41	-0.89	-27.57	-109.29	-109.29	-27.57	-0.52
		90	1.57	0.81	-1.58	-0.33	-0.45	-1.19	-109.82	-184.72	-183.14	-111.41	-10.78
		91	1.77	1.56	-1.02	-1.01	1.56	0.05	-45.51	-196.47	-193.36	-48.62	21.44
68	38	18	2.07	1.32	-1.85	-1.48	0.95	1.02	-97.73	-239.41	-236.68	-100.46	19.46
		20	0.97	1.53	-0.65	1.16	-0.29	-0.82	-30.52	-107.29	-107.15	-30.67	3.35
		90	1.52	0.81	-1.40	-0.28	-0.32	-1.10	-112.96	-178.07	-177.26	-113.77	-7.21
		91	1.70	1.55	-1.00	-1.00	1.54	0.10	-44.60	-189.07	-186.65	-47.01	18.51
69	1	30	0.33	1.74	0.15	1.54	0.35	-0.53	33.65	13.50	21.62	25.53	-9.88
		18	1.31	5.26	2.03	4.42	2.87	1.42	-68.32	-141.65	-138.37	-71.60	15.15
		91	1.41	4.04	1.65	3.34	2.35	-1.08	-50.88	-156.93	-144.26	-63.55	-34.39
		92	0.38	1.99	0.79	1.91	0.88	0.31	7.67	-32.66	6.48	-31.47	6.83
69	2	30	0.25	1.24	0.09	1.10	0.23	-0.37	26.32	10.97	16.25	21.04	-7.29
		18	0.95	3.80	1.43	3.19	2.04	1.04	-47.88	-102.25	-100.13	-50.00	10.52
		91	1.02	2.91	1.18	2.42	1.67	-0.78	-35.83	-114.06	-104.61	-45.28	-25.49
		92	0.27	1.43	0.54	1.36	0.60	0.23	5.25	-23.66	4.36	-22.78	4.98

69	31	30	0.30	1.47	0.05	1.37	0.15	-0.36	32.88	15.48	19.21	29.15	-7.14
		18	1.06	4.35	1.45	3.68	2.13	1.22	-46.37	-112.44	-111.19	-47.63	9.01
		91	1.20	3.32	1.38	2.96	1.74	-0.75	-36.11	-131.69	-120.42	-47.38	-30.82
		92	0.30	1.78	0.50	1.71	0.57	0.29	4.67	-25.05	3.02	-23.40	6.81
69	63	30	0.31	1.39	0.07	1.28	0.18	-0.36	33.40	15.47	19.54	29.33	-7.51
		18	1.05	4.24	1.46	3.58	2.12	1.18	-46.73	-112.44	-110.77	-48.40	10.34
		91	1.17	3.23	1.30	2.80	1.73	-0.80	-37.10	-129.33	-118.64	-47.80	-29.53
		92	0.30	1.64	0.51	1.57	0.59	0.28	6.30	-24.33	4.88	-22.92	6.43
70	1	14	0.86	3.37	1.95	2.57	2.75	-0.71	-65.65	-88.48	-75.76	-78.37	-11.34
		30	0.19	2.40	-0.58	1.42	0.39	1.40	2.67	-7.95	-0.56	-4.71	4.89
		92	0.32	2.11	0.97	2.07	1.01	0.21	-8.18	-34.63	-10.33	-32.48	7.22
		86	0.68	2.85	1.01	2.03	1.84	0.92	-36.55	-75.79	-65.40	-46.94	17.32
70	2	14	0.61	2.38	1.39	1.82	1.96	-0.49	-46.56	-62.71	-53.52	-55.76	-8.00
		30	0.14	1.72	-0.45	1.02	0.26	1.02	2.85	-4.43	-0.32	-1.26	3.61
		92	0.23	1.51	0.67	1.48	0.70	0.16	-6.43	-25.30	-8.20	-23.52	5.51
		86	0.48	2.04	0.70	1.44	1.31	0.66	-25.18	-53.48	-45.63	-33.02	12.67
70	34	14	0.87	2.61	1.77	2.02	2.36	-0.38	-54.47	-96.05	-66.75	-83.77	-18.97
		30	0.14	1.96	-0.40	1.23	0.33	1.09	-0.33	-8.04	-8.03	-0.34	0.27
		92	0.26	1.66	0.77	1.64	0.79	0.11	-9.69	-28.38	-11.88	-26.19	6.01
		86	0.61	2.45	0.89	1.64	1.69	0.78	-49.09	-63.19	-53.06	-59.22	6.34
70	66	14	0.73	2.48	1.62	1.93	2.17	-0.41	-49.83	-78.29	-59.65	-68.47	-13.53
		30	0.12	1.92	-0.47	1.17	0.28	1.11	2.74	-4.35	-3.53	1.92	2.27
		92	0.25	1.65	0.71	1.63	0.74	0.15	-7.80	-26.86	-10.17	-24.49	6.29
		86	0.52	2.29	0.76	1.55	1.50	0.77	-36.36	-56.93	-48.81	-44.48	10.06
71	1	20	1.56	0.36	-0.38	0.29	-0.31	0.22	-66.36	-183.13	-182.68	-66.81	-7.18
		32	0.71	1.36	0.23	1.35	0.24	-0.11	-44.26	-83.62	-44.71	-83.17	4.21
		89	0.70	2.84	-0.59	1.97	0.27	1.49	-18.04	-74.16	-24.33	-67.87	17.71
		90	1.72	3.43	-1.98	2.74	-1.30	-1.79	-131.10	-201.17	-170.18	-162.09	-34.80
71	2	20	1.14	0.26	-0.27	0.21	-0.22	0.16	-46.99	-133.64	-133.27	-47.36	-5.61
		32	0.50	0.99	0.16	0.98	0.17	-0.08	-31.70	-59.04	-32.08	-58.66	3.20
		89	0.48	2.05	-0.44	1.43	0.19	1.08	-11.70	-50.17	-16.64	-45.22	12.88
		90	1.23	2.49	-1.41	1.99	-0.92	-1.30	-92.41	-144.21	-123.13	-113.49	-25.45
71	3	20	1.46	0.23	-0.57	0.21	-0.55	0.12	-41.09	-166.39	-162.62	-44.85	-21.38
		32	0.44	1.23	0.46	1.20	0.50	0.16	-34.52	-46.99	-44.14	-37.37	-5.24
		89	0.29	3.08	-0.43	2.10	0.56	1.57	-10.52	-28.00	-20.47	-18.05	8.65
		90	1.42	3.05	-1.63	2.61	-1.19	-1.35	-84.08	-169.14	-143.30	-109.92	-39.12
71	35	20	1.35	0.26	-0.40	0.21	-0.36	0.16	-45.16	-156.03	-154.48	-46.71	-13.04
		32	0.46	1.13	0.32	1.13	0.32	0.01	-38.68	-49.93	-38.71	-49.91	0.53
		89	0.39	2.60	-0.47	1.79	0.34	1.35	-10.68	-38.52	-17.97	-31.24	12.24
		90	1.35	2.88	-1.54	2.39	-1.05	-1.39	-89.94	-160.82	-138.41	-112.35	-32.96
72	1	16	0.61	1.31	-0.62	1.24	-0.55	-0.35	-58.31	-64.71	-63.14	-59.87	-2.75
		58	0.92	0.83	-1.65	-0.26	-0.56	1.23	-75.00	-101.88	-86.33	-90.54	13.28
		85	1.01	1.58	-0.88	-0.57	1.28	0.81	-79.04	-116.47	-83.70	-111.81	12.36
		88	2.19	1.88	-4.37	-1.05	-1.44	3.12	-140.15	-245.18	-181.76	-203.56	51.37
72	2	16	0.43	0.93	-0.44	0.89	-0.39	-0.25	-41.87	-45.54	-45.13	-42.28	-1.16
		58	0.66	0.59	-1.17	-0.18	-0.40	0.87	-52.46	-72.98	-61.42	-64.03	10.18
		85	0.72	1.12	-0.63	-0.41	0.90	0.58	-56.14	-82.86	-59.89	-79.11	9.28
		88	1.55	1.33	-3.10	-0.76	-1.01	2.21	-98.76	-174.01	-129.20	-143.57	36.93
72	9	16	0.85	0.68	-0.75	0.66	-0.73	0.15	-22.67	-95.54	-48.52	-69.69	34.87
		58	1.09	0.84	-1.96	-0.47	-0.65	1.40	-41.82	-120.48	-63.50	-98.81	35.14
		85	1.31	1.47	-1.13	-0.46	0.79	1.14	-90.93	-153.68	-115.74	-128.87	30.68
		88	2.31	1.74	-3.94	-0.85	-1.34	2.83	-119.95	-260.18	-188.42	-191.71	70.09
72	41	16	0.54	0.83	-0.56	0.83	-0.55	-0.09	-32.41	-64.07	-45.00	-51.49	15.49
		58	0.81	0.72	-1.55	-0.31	-0.52	1.13	-45.25	-91.41	-59.51	-77.15	21.33
		85	0.97	1.28	-0.86	-0.46	0.88	0.83	-72.12	-114.05	-83.83	-102.34	18.81
		88	1.92	1.54	-3.58	-0.85	-1.19	2.55	-109.60	-215.46	-156.98	-168.09	52.64

73	1	9	0.90	1.11	0.06	0.07	1.10	0.12	-44.98	-104.16	-55.53	-93.62	-22.64
		70	1.21	1.46	-0.77	0.01	0.67	-1.07	-91.84	-141.51	-119.92	-113.43	-24.63
		87	0.84	1.49	-1.25	-1.06	1.31	0.69	-50.87	-99.72	-86.24	-64.35	-21.84
		83	0.70	1.07	-0.54	-0.54	1.07	-0.04	-29.78	-81.34	-47.02	-64.10	-24.32
73	2	9	0.65	0.80	0.04	0.05	0.79	0.09	-31.81	-74.36	-39.48	-66.69	-16.36
		70	0.86	1.03	-0.55	4.40e-03	0.48	-0.76	-65.08	-100.89	-85.28	-80.69	-17.75
		87	0.60	1.07	-0.89	-0.76	0.93	0.50	-36.13	-70.89	-61.10	-45.92	-15.63
		83	0.50	0.76	-0.38	-0.38	0.76	-0.03	-21.10	-58.18	-33.43	-45.86	-17.47
73	34	9	1.02	0.60	-0.09	-0.02	0.53	-0.21	-37.00	-117.50	-37.03	-117.47	-1.64
		70	1.36	1.31	-0.93	-0.04	0.42	-1.10	-87.43	-162.89	-88.28	-162.04	-7.93
		87	1.26	1.02	-0.85	-0.75	0.92	0.44	-69.06	-146.85	-83.22	-132.70	-30.01
		83	0.98	0.53	-0.44	-0.42	0.51	-0.14	-36.23	-113.58	-48.54	-101.26	-28.30
73	66	9	0.77	0.71	0.02	0.02	0.71	-0.02	-34.98	-89.21	-36.69	-87.50	-9.49
		70	1.02	1.16	-0.73	-0.03	0.46	-0.91	-79.13	-120.51	-84.60	-115.03	-14.02
		87	0.87	1.09	-0.90	-0.77	0.95	0.50	-53.79	-100.57	-70.55	-83.81	-22.43
		83	0.71	0.69	-0.42	-0.42	0.68	-0.07	-27.55	-82.25	-39.29	-70.51	-22.46
74	1	56	0.54	1.56	0.33	0.48	1.41	0.40	-43.40	-57.92	-57.08	-44.24	-3.39
		34	0.56	1.19	0.23	0.27	1.16	0.19	-39.81	-61.23	-41.39	-59.66	-5.59
		82	1.00	1.02	-0.52	-0.49	0.99	-0.21	-33.00	-114.05	-42.66	-104.38	-26.26
		93	1.16	1.27	-1.10	-0.97	1.14	-0.54	-68.35	-138.70	-88.59	-118.45	-31.85
74	2	56	0.38	1.10	0.24	0.36	0.98	0.29	-30.98	-41.20	-40.63	-31.55	-2.36
		34	0.40	0.84	0.17	0.20	0.81	0.14	-28.48	-43.64	-29.58	-42.54	-3.92
		82	0.71	0.72	-0.37	-0.35	0.70	-0.15	-23.38	-81.09	-30.55	-73.92	-19.04
		93	0.82	0.89	-0.79	-0.70	0.81	-0.38	-48.37	-98.59	-63.24	-83.72	-22.93
74	3	56	0.60	1.00	0.20	0.20	0.99	0.04	-49.11	-67.22	-65.58	-50.75	-5.19
		34	0.64	0.90	0.03	0.04	0.89	-0.10	-52.87	-72.34	-55.81	-69.40	-6.97
		82	1.02	0.89	-0.43	-0.36	0.83	-0.28	-38.14	-118.22	-55.73	-100.63	-33.16
		93	1.14	1.02	-0.92	-0.76	0.85	-0.54	-57.92	-135.23	-88.51	-104.64	-37.80
74	35	56	0.48	1.07	0.26	0.32	1.02	0.20	-39.76	-52.99	-51.83	-40.93	-3.75
		34	0.52	0.87	0.14	0.15	0.87	0.04	-39.47	-57.58	-41.29	-55.76	-5.45
		82	0.86	0.82	-0.41	-0.37	0.78	-0.21	-29.43	-98.26	-40.78	-86.91	-25.54
		93	0.98	0.97	-0.88	-0.76	0.85	-0.45	-52.61	-116.43	-74.31	-94.73	-30.23
75	1	67	0.38	1.05	0.35	0.37	1.03	0.12	-16.96	-44.22	-44.13	-17.06	-1.61
		36	0.47	1.13	0.31	0.36	1.09	0.19	-18.01	-54.02	-53.96	-18.08	-1.52
		94	0.89	1.58	-0.07	0.11	1.40	-0.52	-49.64	-106.09	-104.71	-51.02	8.71
		95	0.78	1.08	-0.30	-0.16	0.93	-0.43	-46.59	-91.80	-79.68	-58.71	20.03
75	2	67	0.27	0.75	0.26	0.27	0.73	0.08	-12.08	-30.81	-30.74	-12.15	-1.14
		36	0.32	0.81	0.23	0.26	0.77	0.13	-12.70	-37.03	-36.98	-12.75	-1.11
		94	0.63	1.12	-0.06	0.08	0.99	-0.37	-35.18	-74.72	-73.75	-36.15	6.11
		95	0.56	0.77	-0.22	-0.11	0.67	-0.31	-32.97	-65.11	-56.34	-41.74	14.32
75	18	67	0.38	0.92	0.29	0.35	0.86	0.19	-18.05	-44.62	-44.40	-18.26	2.40
		36	0.42	0.90	0.24	0.32	0.82	0.21	-15.53	-48.65	-48.64	-15.54	-0.68
		94	0.99	1.17	-0.28	-0.07	0.97	-0.50	-43.24	-117.46	-115.38	-45.32	12.25
		95	0.91	0.90	-0.41	-0.25	0.74	-0.43	-43.88	-107.87	-97.65	-54.10	23.44
75	50	67	0.31	0.85	0.29	0.32	0.82	0.13	-15.13	-36.15	-36.15	-15.13	0.37
		36	0.35	0.88	0.25	0.30	0.83	0.17	-14.01	-40.74	-40.71	-14.04	-0.97
		94	0.78	1.18	-0.14	0.02	1.01	-0.43	-39.02	-93.04	-91.42	-40.64	9.22
		95	0.71	0.85	-0.30	-0.17	0.72	-0.37	-37.83	-83.32	-73.36	-47.78	18.81
76	1	37	0.75	2.84	2.23	2.77	2.30	-0.20	-63.49	-70.79	-68.46	-65.81	3.40
		35	0.36	2.18	0.73	1.10	1.81	0.63	-23.07	-37.93	-31.81	-29.20	7.32
		96	0.96	3.43	3.06	3.06	3.42	-6.65e-03	-77.43	-93.21	-78.14	-92.50	-3.27
		97	0.48	2.74	0.26	2.03	0.97	1.12	-32.14	-53.64	-34.66	-51.12	6.92
76	2	37	0.54	2.04	1.56	1.99	1.61	-0.14	-45.85	-51.25	-49.35	-47.75	2.58
		35	0.25	1.54	0.51	0.79	1.27	0.46	-16.04	-26.86	-22.20	-20.70	5.36
		96	0.68	2.41	2.17	2.17	2.41	3.36e-03	-54.71	-65.70	-55.32	-65.09	-2.52
		97	0.33	1.97	0.15	1.45	0.67	0.82	-22.47	-36.38	-24.52	-34.32	4.94

76	19	37	0.64	2.52	1.60	2.44	1.67	-0.25	-53.96	-61.26	-56.06	-59.16	3.31
		35	0.39	1.67	0.96	1.15	1.47	0.32	-24.94	-40.50	-27.06	-38.38	5.34
		96	0.85	2.64	2.40	2.42	2.62	-0.06	-61.18	-88.04	-63.86	-85.37	-8.05
		97	0.39	2.18	0.13	1.68	0.64	0.88	-30.86	-40.34	-30.99	-40.21	1.09
76	51	37	0.60	2.33	1.60	2.27	1.66	-0.20	-51.10	-57.59	-54.03	-54.66	3.23
		35	0.31	1.65	0.71	0.96	1.40	0.42	-20.21	-32.36	-23.97	-28.60	5.62
		96	0.77	2.56	2.33	2.33	2.56	7.13e-03	-58.03	-77.24	-59.87	-75.40	-5.65
		97	0.35	2.16	0.11	1.62	0.65	0.90	-26.91	-36.67	-28.05	-35.53	3.13
77	1	39	1.68	1.01	0.12	0.15	0.98	0.16	-62.10	-197.46	-197.44	-62.12	1.73
		38	1.79	1.43	-0.07	0.12	1.23	-0.50	-62.72	-209.05	-209.05	-62.72	-0.01
		98	1.92	1.46	-1.58	-1.43	1.31	0.66	-126.28	-224.30	-224.30	-126.29	0.64
		99	1.75	1.13	0.09	0.13	1.09	0.20	-66.60	-205.93	-203.54	-68.99	-18.10
77	2	39	1.23	0.71	0.08	0.10	0.69	0.12	-44.79	-144.16	-144.15	-44.81	1.31
		38	1.31	1.00	-0.06	0.08	0.85	-0.37	-45.31	-152.72	-152.72	-45.31	-0.18
		98	1.40	1.02	-1.14	-1.04	0.91	0.47	-89.52	-163.72	-163.72	-89.52	0.30
		99	1.28	0.81	0.06	0.09	0.77	0.15	-48.26	-150.31	-148.79	-49.78	-12.34
77	8	39	1.53	0.74	-0.15	-0.11	0.71	0.16	-51.77	-177.55	-177.55	-51.77	-0.53
		38	1.60	0.71	-0.22	-0.17	0.66	-0.21	-51.20	-184.45	-184.44	-51.21	1.17
		98	1.66	0.95	-1.40	-1.22	0.77	0.64	-94.26	-194.02	-194.00	-94.28	1.40
		99	1.56	0.91	0.02	0.07	0.86	0.21	-54.69	-182.09	-180.61	-56.17	-13.63
77	40	39	1.46	0.73	-0.02	6.21e-03	0.70	0.15	-50.28	-169.64	-169.63	-50.28	0.63
		38	1.52	0.89	-0.14	-0.03	0.77	-0.33	-50.24	-176.63	-176.63	-50.24	0.20
		98	1.60	0.99	-1.31	-1.18	0.85	0.54	-93.56	-187.57	-187.56	-93.57	0.51
		99	1.50	0.87	0.03	0.08	0.82	0.21	-53.63	-175.28	-173.97	-54.93	-12.53
78	1	40	0.48	2.01	1.58	1.77	1.82	0.21	-35.28	-47.12	-35.43	-46.98	1.32
		39	0.98	1.88	1.04	1.18	1.75	-0.31	-36.76	-111.28	-111.25	-36.79	-1.43
		99	1.32	2.93	1.42	2.03	2.31	0.74	-51.28	-150.44	-147.25	-54.47	17.49
		100	0.36	2.30	1.09	2.30	1.09	1.75e-03	3.30	-33.62	2.93	-33.25	3.68
78	2	40	0.36	1.43	1.13	1.27	1.29	0.15	-26.58	-35.34	-26.69	-35.23	0.99
		39	0.71	1.34	0.75	0.84	1.24	-0.22	-26.88	-81.22	-81.21	-26.90	-0.92
		99	0.96	2.09	1.02	1.47	1.63	0.53	-36.60	-109.43	-106.93	-39.10	13.26
		100	0.25	1.65	0.76	1.65	0.76	-3.93e-03	2.11	-23.92	1.85	-23.67	2.57
78	29	40	0.41	1.53	1.23	1.47	1.29	0.12	-29.45	-41.89	-29.51	-41.83	0.85
		39	0.84	1.50	0.81	1.04	1.27	-0.32	-30.62	-95.06	-94.98	-30.71	-2.39
		99	1.12	2.30	1.31	1.91	1.70	0.49	-40.11	-125.93	-123.46	-42.58	14.34
		100	0.28	2.05	0.73	2.04	0.73	-0.06	0.46	-26.85	0.19	-26.59	2.67
78	61	40	0.40	1.52	1.21	1.41	1.32	0.14	-28.63	-40.27	-28.71	-40.19	0.98
		39	0.83	1.43	0.81	0.98	1.27	-0.27	-30.62	-94.53	-94.50	-30.65	-1.48
		99	1.10	2.25	1.18	1.75	1.68	0.53	-39.54	-124.37	-121.68	-42.23	14.86
		100	0.27	1.90	0.76	1.89	0.76	-0.04	2.38	-24.88	2.18	-24.68	2.33
79	1	36	0.29	1.38	0.93	1.03	1.27	0.19	-13.82	-30.78	-30.78	-13.82	0.05
		40	0.46	1.90	1.66	1.82	1.74	-0.11	-37.00	-43.68	-37.26	-43.43	-1.29
		100	0.38	2.26	0.89	2.12	1.03	-0.41	-8.82	-41.45	-15.47	-34.79	-13.15
		94	0.59	2.40	0.91	1.38	1.94	-0.69	-37.43	-65.27	-62.17	-40.52	-8.75
79	2	36	0.20	0.97	0.66	0.73	0.90	0.13	-9.67	-20.35	-20.35	-9.67	-0.06
		40	0.34	1.35	1.18	1.31	1.22	-0.08	-28.03	-32.77	-28.25	-32.55	-1.00
		100	0.27	1.62	0.61	1.52	0.71	-0.30	-6.67	-30.04	-11.86	-24.86	-9.71
		94	0.41	1.72	0.64	0.98	1.38	-0.50	-26.21	-45.81	-43.32	-28.70	-6.53
79	12	36	0.26	1.41	0.91	1.21	1.11	0.24	-15.23	-25.73	-25.69	-15.27	-0.69
		40	0.43	1.80	1.07	1.80	1.07	-0.02	-37.11	-41.15	-37.98	-40.27	-1.67
		100	0.33	2.02	0.41	1.93	0.51	-0.38	-12.85	-37.07	-20.47	-29.45	-11.25
		94	0.49	2.02	0.90	1.36	1.57	-0.55	-32.72	-53.38	-50.99	-35.11	-6.60
79	44	36	0.21	1.17	0.80	0.95	1.02	0.18	-12.00	-21.28	-21.26	-12.01	-0.39
		40	0.40	1.58	1.17	1.57	1.18	-0.05	-33.24	-38.03	-33.67	-37.60	-1.37
		100	0.30	1.86	0.52	1.76	0.63	-0.36	-9.10	-33.66	-16.01	-26.76	-11.04
		94	0.45	1.91	0.73	1.15	1.50	-0.56	-29.37	-48.87	-46.43	-31.82	-6.46

80	1	38	1.03	2.67	0.69	1.31	2.05	-0.92	-38.91	-118.10	-115.53	-41.48	-14.03
		37	0.76	2.87	2.31	2.82	2.37	0.16	-60.79	-75.07	-61.35	-74.51	2.77
		97	0.40	2.08	0.90	2.05	0.93	-0.18	-21.23	-42.66	-26.37	-37.53	-9.15
		98	1.34	4.95	3.02	4.70	3.27	0.65	-90.11	-138.09	-136.74	-91.46	-7.94
80	2	38	0.75	1.90	0.47	0.94	1.44	-0.67	-28.41	-86.72	-84.86	-30.28	-10.27
		37	0.55	2.06	1.62	2.03	1.66	0.12	-43.76	-54.44	-44.13	-54.06	1.96
		97	0.27	1.49	0.62	1.47	0.63	-0.12	-14.14	-28.57	-18.28	-24.43	-6.53
		98	0.97	3.59	2.11	3.40	2.30	0.49	-63.23	-100.23	-99.33	-64.13	-5.69
80	6	38	0.94	2.37	1.15	1.99	1.53	-0.57	-33.35	-104.28	-102.79	-34.85	-10.18
		37	0.63	3.04	1.20	3.04	1.20	0.05	-51.83	-61.00	-52.32	-60.51	2.06
		97	0.32	1.99	-0.08	1.92	-0.01	-0.37	-16.61	-33.36	-27.30	-22.67	-8.05
		98	1.14	4.30	2.20	4.19	2.31	0.46	-66.01	-119.61	-119.14	-66.48	-4.98
80	38	38	0.89	2.13	0.80	1.43	1.50	-0.67	-32.56	-101.14	-99.36	-34.33	-10.88
		37	0.60	2.55	1.49	2.54	1.50	0.10	-48.47	-59.76	-48.90	-59.33	2.16
		97	0.28	1.76	0.32	1.73	0.35	-0.20	-14.30	-29.36	-22.05	-21.61	-7.52
		98	1.09	4.08	2.19	3.93	2.34	0.51	-64.93	-114.45	-113.81	-65.57	-5.57
81	1	35	0.43	2.56	0.17	1.01	1.72	1.14	-20.10	-49.13	-40.18	-29.06	13.41
		56	0.56	1.56	0.42	0.49	1.49	0.28	-40.66	-62.91	-61.38	-42.19	-5.63
		93	1.17	1.03	-1.08	-0.99	0.94	-0.42	-66.13	-139.56	-82.42	-123.27	-30.51
		96	1.78	2.42	-2.65	-2.20	1.97	-1.44	-99.01	-202.77	-181.11	-120.67	-42.17
81	2	35	0.30	1.81	0.13	0.74	1.20	0.81	-14.24	-34.78	-28.32	-20.70	9.54
		56	0.40	1.09	0.31	0.36	1.04	0.20	-29.05	-44.74	-43.68	-30.11	-3.94
		93	0.83	0.73	-0.77	-0.71	0.67	-0.29	-46.86	-99.11	-58.86	-87.11	-21.98
		96	1.27	1.68	-1.89	-1.58	1.38	-1.00	-69.86	-144.18	-128.90	-85.14	-30.04
81	5	35	0.48	1.52	0.16	0.49	1.19	0.58	-28.32	-56.32	-53.13	-31.52	8.91
		56	0.63	1.04	0.08	0.08	1.04	-7.66e-03	-44.63	-74.13	-71.65	-47.12	-8.19
		93	1.24	0.87	-0.86	-0.73	0.73	-0.47	-76.11	-147.47	-112.35	-111.22	-35.68
		96	1.79	1.85	-2.10	-1.65	1.41	-1.25	-86.55	-204.18	-186.46	-104.27	-42.07
81	37	35	0.37	1.75	0.17	0.68	1.25	0.74	-20.64	-43.52	-38.34	-25.81	9.57
		56	0.51	1.09	0.25	0.27	1.07	0.13	-36.69	-58.10	-56.28	-38.52	-5.98
		93	1.01	0.80	-0.84	-0.75	0.71	-0.37	-60.36	-120.70	-81.49	-99.57	-28.78
		96	1.52	1.79	-2.05	-1.68	1.42	-1.13	-78.23	-173.49	-156.18	-95.53	-36.72
82	1	33	0.27	0.83	0.22	0.22	0.83	0.04	-19.88	-29.97	-29.96	-19.89	-0.26
		67	0.38	1.00	0.30	0.31	1.00	0.04	-17.22	-44.38	-44.20	-17.40	-2.18
		95	0.79	1.11	-0.14	-0.03	1.00	-0.36	-45.29	-91.87	-78.88	-58.27	20.89
		81	0.70	1.02	-0.20	-0.09	0.90	-0.35	-28.94	-78.76	-46.85	-60.85	23.91
82	2	33	0.19	0.59	0.16	0.16	0.59	0.03	-14.26	-21.08	-21.07	-14.27	-0.20
		67	0.27	0.71	0.22	0.23	0.71	0.03	-12.26	-30.91	-30.78	-12.39	-1.55
		95	0.56	0.79	-0.10	-0.02	0.71	-0.26	-32.03	-65.17	-55.77	-41.43	14.94
		81	0.50	0.73	-0.15	-0.07	0.64	-0.26	-20.36	-56.19	-33.20	-43.36	17.18
82	14	33	0.35	0.79	0.23	0.25	0.76	0.12	-30.41	-37.70	-37.42	-30.69	1.40
		67	0.39	0.86	0.29	0.31	0.84	0.09	-22.81	-45.40	-45.39	-22.82	-0.54
		95	0.79	0.89	-0.25	-0.15	0.79	-0.32	-36.65	-92.47	-75.51	-53.61	25.68
		81	0.75	0.87	-0.28	-0.19	0.78	-0.31	-29.05	-85.62	-53.61	-61.06	28.04
82	46	33	0.26	0.69	0.20	0.21	0.68	0.07	-21.83	-28.02	-27.97	-21.88	0.55
		67	0.31	0.80	0.26	0.27	0.80	0.05	-17.12	-36.63	-36.57	-17.18	-1.10
		95	0.66	0.86	-0.16	-0.07	0.76	-0.29	-33.90	-77.30	-63.79	-47.41	20.10
		81	0.61	0.81	-0.21	-0.12	0.72	-0.29	-23.70	-69.26	-41.28	-51.68	22.18
83	1	136	2.01	1.04	-2.01	-0.61	-0.36	1.52	3.58	-4.69	3.03	-4.14	2.06
		77	3.71	2.04	-4.93	-3.10	0.21	-3.07	-0.52	-11.80	-2.17	-10.15	3.99
		104	5.21	2.93	-3.92	2.88	-3.88	0.54	14.67	-3.99	-2.99	13.66	-4.21
		113	5.79	5.58	-4.68	-3.73	4.64	-2.96	19.50	3.24	3.42	19.32	-1.69
83	2	136	1.30	0.77	-1.43	-0.42	-0.24	1.10	2.33	-2.88	1.99	-2.54	1.30
		77	2.60	1.45	-3.56	-2.24	0.13	-2.21	-0.38	-8.21	-1.39	-7.21	2.62
		104	3.61	2.12	-2.63	2.09	-2.61	0.35	10.28	-2.63	-1.99	9.65	-2.78
		113	3.82	3.88	-3.31	-2.67	3.23	-2.05	12.61	2.17	2.27	12.50	-1.03

83	22	136	1.25	0.71	-1.49	-0.57	-0.21	1.08	2.50	-2.48	2.03	-2.01	1.46
		77	2.88	1.69	-4.12	-2.53	0.10	-2.59	-0.29	-8.89	-1.36	-7.82	2.84
		104	3.64	2.55	-2.50	2.54	-2.50	0.10	10.28	-2.80	-2.02	9.50	-3.09
		113	4.01	4.24	-3.35	-2.63	3.51	-2.23	13.10	2.18	2.31	12.96	-1.20
83	54	136	1.28	0.78	-1.55	-0.54	-0.23	1.15	2.40	-2.68	2.02	-2.30	1.33
		77	2.78	1.63	-4.04	-2.50	0.09	-2.52	-0.35	-8.60	-1.37	-7.57	2.72
		104	3.66	2.40	-2.52	2.40	-2.51	0.17	10.44	-2.72	-2.03	9.74	-2.94
		113	3.93	4.17	-3.45	-2.78	3.50	-2.16	12.78	2.20	2.30	12.67	-1.05
84	1	94	7.66	4.97	0.15	1.74	3.38	-2.26	33.19	7.81	8.26	32.74	3.35
		13	14.90	-0.62	-30.63	-0.65	-30.59	1.07	32.09	-8.93	-8.86	32.02	1.78
		107	4.69	-0.11	-7.89	-5.24	-2.76	3.69	-10.73	-19.90	-11.13	-19.50	-1.87
		120	8.13	0.88	-17.09	-5.18	-11.03	8.50	12.58	-20.15	12.11	-19.67	-3.92
84	2	94	5.49	3.53	0.26	1.22	2.57	-1.48	23.63	5.46	5.83	23.26	2.57
		13	10.63	-0.45	-21.75	-0.48	-21.73	0.69	22.85	-6.56	-6.51	22.80	1.22
		107	3.35	-7.44e-03	-5.65	-3.74	-1.91	2.67	-7.84	-14.16	-8.12	-13.89	-1.29
		120	5.69	0.52	-11.93	-3.73	-7.68	5.90	8.95	-14.26	8.56	-13.87	-2.98
84	12	94	6.00	3.93	0.58	2.40	2.11	-1.67	26.15	5.91	5.91	26.15	0.10
		13	12.73	0.59	-24.23	0.59	-24.22	0.47	28.70	-6.99	-6.94	28.65	-1.33
		107	3.00	-1.17	-6.22	-4.71	-2.68	2.32	-7.96	-9.47	-8.09	-9.34	0.42
		120	5.48	-0.73	-12.89	-4.83	-8.80	5.75	9.02	-12.02	8.92	-11.92	-1.48
84	44	94	5.78	3.64	0.64	1.76	2.52	-1.45	24.94	5.88	6.00	24.81	1.54
		13	11.84	-0.04	-23.83	-0.06	-23.81	0.68	25.75	-6.85	-6.85	25.75	0.08
		107	3.21	-0.53	-5.95	-4.21	-2.27	2.53	-8.12	-12.30	-8.19	-12.24	-0.52
		120	5.69	-0.06	-12.66	-4.34	-8.38	5.97	9.08	-13.51	8.82	-13.25	-2.40
85	1	137	2.01	1.04	-2.01	-0.61	-0.36	1.52	4.69	-3.58	-3.03	4.14	-2.06
		76	3.71	2.04	-4.93	-3.10	0.21	-3.07	11.80	0.52	2.17	10.15	-3.99
		106	5.21	2.93	-3.92	2.88	-3.88	0.54	3.99	-14.67	2.99	-13.66	4.21
		112	5.79	5.58	-4.68	-3.73	4.64	-2.96	-3.24	-19.50	-3.42	-19.32	1.69
85	2	137	1.30	0.77	-1.43	-0.42	-0.24	1.10	2.88	-2.33	-1.99	2.54	-1.30
		76	2.60	1.45	-3.56	-2.24	0.13	-2.21	8.21	0.38	1.39	7.21	-2.62
		106	3.61	2.12	-2.63	2.09	-2.61	0.35	2.63	-10.28	1.99	-9.65	2.78
		112	3.82	3.88	-3.31	-2.67	3.23	-2.05	-2.17	-12.61	-2.27	-12.50	1.03
85	24	137	1.25	0.71	-1.49	-0.57	-0.21	1.08	2.48	-2.50	-2.03	2.01	-1.46
		76	2.88	1.69	-4.12	-2.53	0.10	-2.59	8.89	0.29	1.36	7.82	-2.84
		106	3.64	2.55	-2.50	2.54	-2.50	0.10	2.80	-10.28	2.02	-9.50	3.09
		112	4.01	4.24	-3.35	-2.63	3.51	-2.23	-2.18	-13.10	-2.31	-12.96	1.20
85	56	137	1.28	0.78	-1.55	-0.54	-0.23	1.15	2.68	-2.40	-2.02	2.30	-1.33
		76	2.78	1.63	-4.04	-2.50	0.09	-2.52	8.60	0.35	1.37	7.57	-2.72
		106	3.66	2.40	-2.52	2.40	-2.51	0.17	2.72	-10.44	2.03	-9.74	2.94
		112	3.93	4.17	-3.45	-2.78	3.50	-2.16	-2.20	-12.78	-2.30	-12.67	1.05
86	1	99	14.08	6.58	1.46	2.01	6.04	-1.57	-11.22	-59.83	-13.31	-57.74	-9.87
		17	23.28	-1.16	-39.81	-1.51	-39.45	3.69	14.58	-57.77	13.73	-56.92	-7.79
		106	8.52	-1.55	-6.00	-5.10	-2.45	1.79	39.50	13.56	15.85	37.21	7.37
		121	12.22	0.18	-20.00	-6.61	-13.21	9.53	33.10	-21.76	-19.74	31.08	10.32
86	2	99	10.30	4.62	1.11	1.36	4.36	-0.91	-7.94	-43.61	-9.58	-41.97	-7.48
		17	16.84	-0.88	-28.32	-1.10	-28.10	2.45	10.78	-42.00	10.15	-41.37	-5.74
		106	6.19	-1.02	-4.24	-3.62	-1.64	1.27	28.83	9.97	11.68	27.12	5.42
		121	8.79	-0.07	-13.89	-4.72	-9.23	6.53	24.01	-15.86	-14.27	22.42	7.80
86	24	99	11.17	3.63	1.22	1.32	3.53	-0.49	-8.39	-47.91	-10.00	-46.31	-7.81
		17	18.90	-0.84	-30.44	-1.06	-30.22	2.54	12.30	-47.89	11.71	-47.31	-5.90
		106	6.61	-1.42	-4.56	-3.91	-2.08	1.28	30.47	11.22	12.72	28.97	5.17
		121	9.76	-0.29	-14.76	-4.99	-10.06	6.77	26.56	-17.23	-15.72	25.05	7.98
86	56	99	11.30	3.97	1.07	1.24	3.81	-0.68	-8.50	-48.35	-10.31	-46.54	-8.31
		17	18.63	-0.95	-30.13	-1.14	-29.94	2.36	12.09	-47.23	11.40	-46.54	-6.35
		106	6.80	-1.31	-4.27	-3.79	-1.79	1.09	31.54	10.94	12.75	29.73	5.83
		121	9.70	-0.29	-14.36	-4.87	-9.78	6.59	26.56	-17.44	-15.70	24.82	8.59

87	1	38	17.96	17.16	6.50	7.79	15.87	-3.47	67.71	6.94	7.15	67.49	3.60
		98	22.10	0.02	-26.12	-0.13	-25.97	2.00	67.49	-6.46	-6.05	67.08	5.50
		109	9.87	-0.76	-15.00	-8.26	-7.50	7.11	-3.39	-39.96	-4.11	-39.25	-5.05
		125	8.86	1.47	-10.53	-8.04	-1.02	4.87	6.53	-27.24	5.98	-26.68	-4.28
87	2	38	12.99	12.04	4.66	5.38	11.32	-2.19	49.02	5.08	5.23	48.87	2.60
		98	16.00	-0.08	-18.59	-0.16	-18.51	1.20	49.11	-4.70	-4.36	48.78	4.21
		109	7.14	-0.49	-10.49	-5.75	-5.23	4.99	-2.34	-29.07	-2.92	-28.49	-3.88
		125	6.28	0.98	-7.31	-5.70	-0.62	3.27	4.77	-19.16	4.36	-18.75	-3.10
87	9	38	14.57	10.44	3.84	4.33	9.95	-1.72	56.41	5.08	5.17	56.32	2.18
		98	18.64	-1.16	-21.47	-1.25	-21.37	1.41	57.82	-5.59	-5.19	57.41	5.05
		109	7.44	-1.10	-11.54	-5.61	-7.02	5.17	-2.13	-28.94	-2.85	-28.22	-4.34
		125	5.96	-0.05	-8.10	-5.72	-2.43	3.67	5.34	-18.26	4.85	-17.76	-3.38
87	41	38	14.37	11.46	4.33	4.89	10.90	-1.92	55.10	5.37	5.50	54.97	2.52
		98	18.01	-0.62	-20.50	-0.69	-20.43	1.21	55.89	-5.27	-4.85	55.47	5.05
		109	7.70	-0.93	-10.88	-5.73	-6.08	4.97	-2.17	-30.89	-2.91	-30.15	-4.53
		125	6.36	0.44	-7.76	-5.84	-1.49	3.47	5.26	-19.57	4.79	-19.10	-3.35
88	1	129	0.92	1.47	-2.18	-0.07	-0.64	1.81	-0.16	-2.11	-0.17	-2.10	0.15
		72	2.21	1.98	-3.59	-2.21	0.60	-2.40	7.10	0.18	0.18	7.10	0.03
		110	3.86	2.90	-4.38	2.67	-4.15	1.27	1.13	-10.62	1.12	-10.61	-0.27
		127	2.61	6.30	-6.16	-4.26	4.40	-4.48	0.77	-1.43	-1.23	0.57	-0.63
88	2	129	0.69	1.01	-1.54	-0.08	-0.45	1.26	-0.04	-1.64	-0.05	-1.63	0.15
		72	1.55	1.39	-2.55	-1.58	0.42	-1.70	4.98	0.05	0.05	4.98	0.10
		110	2.68	2.03	-2.98	1.90	-2.86	0.78	0.75	-7.45	0.74	-7.44	-0.26
		127	1.90	4.40	-4.32	-3.03	3.11	-3.09	0.97	-0.95	-0.81	0.83	-0.49
88	31	129	1.24	1.27	-1.95	-0.33	-0.34	1.61	0.16	-3.60	-0.02	-3.42	0.80
		72	0.92	1.30	-2.56	-1.84	0.58	-1.50	1.44	-0.46	-5.67e-03	0.99	0.81
		110	3.85	2.62	-3.04	2.46	-2.88	0.95	0.88	-12.09	0.81	-12.02	-0.97
		127	1.91	4.65	-3.94	-2.78	3.49	-2.94	0.66	-1.80	-0.74	-0.41	-1.22
88	63	129	0.95	1.11	-1.77	-0.24	-0.42	1.44	0.06	-2.58	-0.01	-2.50	0.44
		72	1.21	1.39	-2.64	-1.74	0.49	-1.68	3.50	-0.05	-1.44e-03	3.45	0.43
		110	3.24	2.31	-3.07	2.20	-2.96	0.77	0.80	-9.59	0.76	-9.56	-0.59
		127	1.98	4.66	-4.30	-3.04	3.41	-3.11	0.91	-1.18	-0.78	0.52	-0.82
89	1	35	11.61	16.28	7.08	7.58	15.77	-2.09	-4.88	-40.14	-5.16	-39.87	-3.08
		96	16.02	0.92	-23.86	0.92	-23.86	0.03	5.39	-43.59	5.39	-43.59	0.33
		110	7.39	1.44	-17.64	-9.10	-7.10	9.48	25.78	4.56	4.56	25.78	0.14
		123	6.69	0.95	-8.64	-7.04	-0.64	3.57	20.10	-4.58	-4.05	19.57	3.56
89	2	35	8.23	11.55	4.97	5.26	11.26	-1.35	-3.53	-28.39	-3.73	-28.20	-2.21
		96	11.40	0.62	-16.89	0.62	-16.89	-0.09	3.86	-31.08	3.86	-31.08	0.14
		110	5.22	1.07	-12.43	-6.40	-4.96	6.71	18.33	3.24	3.25	18.32	0.21
		123	4.67	0.71	-5.98	-4.98	-0.30	2.39	13.83	-3.30	-2.91	13.44	2.56
89	3	35	8.91	11.34	5.08	5.46	10.95	-1.51	-3.52	-31.54	-3.67	-31.39	-2.04
		96	13.09	0.56	-19.32	0.55	-19.31	-0.33	4.32	-35.91	4.31	-35.91	0.30
		110	5.09	0.18	-13.61	-6.95	-6.48	6.89	16.06	3.34	3.34	16.06	-0.09
		123	4.14	-0.45	-6.54	-5.59	-1.40	2.21	11.72	-3.47	-3.01	11.26	2.60
89	35	35	8.72	11.97	5.20	5.50	11.67	-1.38	-3.64	-30.20	-3.82	-30.02	-2.19
		96	12.49	0.59	-18.59	0.59	-18.59	-0.20	4.16	-34.06	4.16	-34.06	0.25
		110	5.32	0.76	-13.31	-6.79	-5.76	7.02	17.91	3.34	3.34	17.91	0.08
		123	4.53	0.28	-6.39	-5.43	-0.68	2.33	13.06	-3.44	-3.01	12.63	2.64
90	1	128	0.92	1.47	-2.18	-0.07	-0.64	1.81	2.11	0.16	0.17	2.10	-0.15
		73	2.21	1.98	-3.59	-2.21	0.60	-2.40	-0.18	-7.10	-0.18	-7.10	-0.03
		111	3.86	2.90	-4.38	2.67	-4.15	1.27	10.62	-1.13	-1.12	10.61	0.27
		126	2.61	6.30	-6.16	-4.26	4.40	-4.48	1.43	-0.77	1.23	-0.57	0.63
90	2	128	0.69	1.01	-1.54	-0.08	-0.45	1.26	1.64	0.04	0.05	1.63	-0.15
		73	1.55	1.39	-2.55	-1.58	0.42	-1.70	-0.05	-4.98	-0.05	-4.98	-0.10
		111	2.68	2.03	-2.98	1.90	-2.86	0.78	7.45	-0.75	-0.74	7.44	0.26
		126	1.90	4.40	-4.32	-3.03	3.11	-3.09	0.95	-0.97	0.81	-0.83	0.49

90	29	128	1.24	1.27	-1.95	-0.33	-0.34	1.61	3.60	-0.16	0.02	3.42	-0.80
		73	0.92	1.30	-2.56	-1.84	0.58	-1.50	0.46	-1.44	5.67e-03	-0.99	-0.81
		111	3.85	2.62	-3.04	2.46	-2.88	0.95	12.09	-0.88	-0.81	12.02	0.97
		126	1.91	4.65	-3.94	-2.78	3.49	-2.94	1.80	-0.66	0.74	0.41	1.22
90	61	128	0.95	1.11	-1.77	-0.24	-0.42	1.44	2.58	-0.06	0.01	2.50	-0.44
		73	1.21	1.39	-2.64	-1.74	0.49	-1.68	0.05	-3.50	1.44e-03	-3.45	-0.43
		111	3.24	2.31	-3.07	2.20	-2.96	0.77	9.59	-0.80	-0.76	9.56	0.59
		126	1.98	4.66	-4.30	-3.04	3.41	-3.11	1.18	-0.91	0.78	-0.52	0.82
91	1	122	10.78	0.04	-2.65	-0.07	-2.54	0.53	-5.54	-45.96	-23.38	-28.13	20.07
		121	9.72	4.52	0.12	1.81	2.83	2.14	36.00	-1.99	20.56	13.45	18.66
		106	8.47	13.67	2.16	9.12	6.71	-5.63	-12.55	-30.47	-15.37	-27.65	6.53
		112	20.01	-2.19	-7.48	-5.56	-4.12	2.55	86.43	9.22	9.79	85.86	6.63
91	2	122	7.31	0.01	-1.88	-0.06	-1.81	0.37	-3.38	-30.95	-15.44	-18.89	13.67
		121	6.43	3.27	0.06	1.30	2.02	1.57	23.67	-1.09	13.52	9.06	12.18
		106	5.95	9.84	1.50	6.59	4.75	-4.07	-9.48	-21.30	-11.32	-19.47	4.29
		112	13.37	-1.53	-5.38	-4.01	-2.90	1.84	57.97	6.90	7.25	57.61	4.23
91	9	122	6.93	0.83	-2.41	0.75	-2.32	0.52	-2.93	-29.07	-15.30	-16.69	13.05
		121	7.22	3.96	0.50	2.25	2.20	1.73	25.30	-3.23	13.61	8.47	14.03
		106	6.62	11.10	1.79	7.93	4.96	-4.41	-7.59	-23.31	-10.45	-20.45	6.06
		112	13.64	-1.30	-5.79	-3.71	-3.38	2.24	59.79	10.55	10.69	59.64	2.65
91	41	122	7.23	0.32	-2.13	0.25	-2.06	0.43	-2.99	-30.40	-15.38	-18.02	13.64
		121	6.71	3.73	0.19	1.75	2.16	1.76	24.08	-1.84	13.53	8.71	12.74
		106	6.38	10.83	1.61	7.52	4.92	-4.43	-9.48	-22.57	-11.83	-20.21	5.03
		112	13.37	-1.46	-5.77	-4.12	-3.12	2.10	58.56	9.06	9.31	58.31	3.50
92	1	120	9.80	2.96	0.55	1.13	2.39	-1.02	37.67	-2.44	20.45	14.77	-19.85
		122	10.30	-2.78e-03	-2.45	-0.05	-2.41	-0.33	-6.57	-44.62	-23.36	-27.82	-18.89
		112	21.74	-2.60	-6.23	-4.39	-4.44	-1.81	88.48	-1.04	-0.48	87.92	-7.07
		107	8.15	10.70	1.95	6.10	6.55	4.37	-2.67	-28.97	-4.26	-27.37	-6.28
92	2	120	6.49	2.11	0.39	0.79	1.71	-0.72	24.97	-1.44	13.42	10.10	-13.10
		122	6.94	-0.01	-1.74	-0.04	-1.72	-0.22	-4.18	-29.94	-15.42	-18.71	-12.77
		112	14.67	-1.87	-4.43	-3.13	-3.16	-1.28	59.60	-0.76	-0.41	59.25	-4.57
		107	5.70	7.62	1.38	4.34	4.66	3.12	-2.06	-20.31	-3.02	-19.35	-4.08
92	9	120	6.00	2.71	1.40	1.78	2.32	-0.60	22.09	-2.68	12.15	7.25	-12.14
		122	7.54	0.93	-2.25	0.92	-2.24	-0.11	-1.47	-31.62	-16.53	-16.56	-15.08
		112	15.99	-1.52	-4.59	-2.37	-3.74	-1.38	62.39	-4.67	-4.15	61.87	-5.90
		107	6.13	8.64	2.19	5.47	5.37	3.23	-5.75	-23.34	-6.05	-23.04	-2.28
92	41	120	6.26	2.39	0.83	1.20	2.01	-0.67	23.70	-1.87	12.83	9.00	-12.64
		122	7.21	0.35	-1.99	0.34	-1.98	-0.16	-3.03	-30.71	-15.85	-17.89	-13.80
		112	15.29	-1.85	-4.55	-2.92	-3.48	-1.32	60.95	-2.66	-2.25	60.54	-5.11
		107	5.95	8.23	1.74	4.91	5.06	3.25	-3.55	-21.90	-4.15	-21.30	-3.26
93	1	119	9.93	1.14	-2.59	0.16	-1.62	-1.64	4.44	-37.69	-29.82	-3.42	-16.41
		118	9.92	2.01	-0.69	-0.60	1.92	-0.47	35.03	-9.89	26.59	-1.44	-17.55
		115	15.81	-1.83	-3.21	-2.79	-2.24	0.63	64.28	-0.28	64.22	-0.22	-1.97
		116	14.45	1.16	-1.12	-1.04	1.07	-0.44	-42.44	-68.14	-67.84	-42.74	-2.76
93	2	119	6.71	0.82	-1.85	0.11	-1.14	-1.18	3.16	-25.30	-19.82	-2.32	-11.22
		118	6.52	1.43	-0.51	-0.45	1.37	-0.35	23.11	-6.30	17.70	-0.90	-11.39
		115	10.70	-1.30	-2.31	-2.03	-1.59	0.45	43.47	-0.12	43.43	-0.08	-1.31
		116	9.68	0.83	-0.81	-0.75	0.77	-0.31	-28.12	-45.63	-45.44	-28.31	-1.81
93	12	119	6.96	0.26	-1.83	-0.61	-0.96	-1.03	4.06	-25.55	-20.29	-1.21	-11.32
		118	6.28	1.46	-1.24	-1.24	1.46	0.03	21.85	-5.24	17.43	-0.83	-10.00
		115	11.20	-1.11	-3.19	-2.70	-1.60	0.88	45.03	-4.52e-03	45.02	7.02e-03	-0.72
		116	9.67	1.04	-1.31	-1.30	1.02	-0.17	-26.61	-45.32	-45.11	-26.82	-1.97
93	44	119	6.89	0.61	-1.88	-0.19	-1.07	-1.17	3.63	-25.60	-20.05	-1.91	-11.46
		118	6.36	1.47	-0.85	-0.82	1.45	-0.23	22.49	-5.63	17.67	-0.81	-10.60
		115	11.05	-1.25	-2.79	-2.42	-1.61	0.66	44.65	1.54e-03	44.62	0.03	-1.05
		116	9.71	0.95	-1.06	-1.03	0.91	-0.27	-27.33	-45.70	-45.51	-27.52	-1.87

94	1	117	10.39	1.91	-0.33	-0.33	1.91	-0.03	35.85	-11.14	26.12	-1.42	19.03
		119	9.37	0.38	-2.39	-0.09	-1.92	1.04	3.56	-36.49	-29.80	-3.13	14.94
		116	14.10	0.71	-0.86	-0.82	0.66	0.26	-43.30	-66.26	-66.00	-43.56	2.43
		114	14.56	-1.28	-2.15	-1.64	-1.79	-0.43	59.51	-0.98	59.42	-0.89	2.34
94	2	117	6.86	1.36	-0.24	-0.24	1.35	-0.03	23.69	-7.25	17.32	-0.89	12.50
		119	6.28	0.26	-1.70	-0.07	-1.37	0.74	2.49	-24.37	-19.79	-2.10	10.11
		116	9.41	0.51	-0.62	-0.59	0.47	0.18	-28.76	-44.22	-44.06	-28.92	1.56
		114	9.76	-0.91	-1.52	-1.16	-1.28	-0.30	39.89	-0.64	39.83	-0.58	1.59
94	34	117	7.18	0.83	-0.61	-0.57	0.79	-0.25	22.77	-9.87	18.03	-5.13	11.50
		119	5.96	-0.10	-1.82	-0.44	-1.48	0.68	2.87	-22.76	-19.04	-0.85	9.03
		116	9.37	0.53	-0.89	-0.82	0.46	0.31	-27.17	-44.06	-43.77	-27.47	2.22
		114	10.42	-1.28	-2.06	-1.35	-1.99	-0.23	40.41	-5.10	40.27	-4.95	2.58
94	66	117	6.96	1.17	-0.40	-0.38	1.15	-0.15	23.20	-8.21	17.60	-2.61	12.02
		119	6.15	0.08	-1.79	-0.25	-1.45	0.72	2.64	-23.72	-19.47	-1.61	9.69
		116	9.40	0.54	-0.77	-0.72	0.49	0.24	-28.03	-44.18	-43.98	-28.23	1.79
		114	10.04	-1.11	-1.77	-1.26	-1.63	-0.28	40.15	-2.52	40.06	-2.43	2.02
95	1	113	20.01	-2.19	-7.48	-5.56	-4.12	-2.55	86.43	9.22	9.79	85.86	-6.63
		104	8.47	13.67	2.16	9.12	6.71	5.63	-12.55	-30.47	-15.37	-27.65	-6.53
		118	9.72	4.52	0.12	1.81	2.83	-2.14	36.00	-1.99	20.56	13.45	-18.66
		119	10.78	0.04	-2.65	-0.07	-2.54	-0.53	-5.54	-45.96	-23.38	-28.13	-20.07
95	2	113	13.37	-1.53	-5.38	-4.01	-2.90	-1.84	57.97	6.90	7.25	57.61	-4.23
		104	5.95	9.84	1.50	6.59	4.75	4.07	-9.48	-21.30	-11.32	-19.47	-4.29
		118	6.43	3.27	0.06	1.30	2.02	-1.57	23.67	-1.09	13.52	9.06	-12.18
		119	7.31	0.01	-1.88	-0.06	-1.81	-0.37	-3.38	-30.95	-15.44	-18.89	-13.67
95	18	113	12.96	-1.67	-5.94	-4.95	-2.65	-1.80	56.13	4.99	5.59	55.54	-5.50
		104	6.05	10.41	1.20	6.69	4.92	4.52	-14.55	-21.18	-15.55	-20.17	-2.38
		118	5.50	3.33	-0.41	0.76	2.16	-1.73	20.80	0.99	13.04	8.75	-9.67
		119	7.99	-0.70	-1.64	-0.74	-1.59	-0.20	-2.91	-33.76	-15.87	-20.79	-15.23
95	50	113	13.09	-1.61	-5.84	-4.64	-2.81	-1.91	57.04	6.75	7.19	56.60	-4.69
		104	6.14	10.54	1.36	7.00	4.90	4.47	-12.37	-21.68	-13.96	-20.10	-3.50
		118	6.00	3.47	-0.19	1.13	2.14	-1.76	22.20	-0.09	13.29	8.82	-10.92
		119	7.67	-0.31	-1.82	-0.37	-1.76	-0.30	-2.98	-32.37	-15.62	-19.73	-14.55
96	1	108	8.15	10.70	1.95	6.10	6.55	-4.37	-2.67	-28.97	-4.26	-27.37	6.28
		113	21.74	-2.60	-6.23	-4.39	-4.44	1.81	88.48	-1.04	-0.48	87.92	7.07
		119	10.30	-2.78e-03	-2.45	-0.05	-2.41	0.33	-6.57	-44.62	-23.36	-27.82	18.89
		117	9.80	2.96	0.55	1.13	2.39	1.02	37.67	-2.44	20.45	14.77	19.85
96	2	108	5.70	7.62	1.38	4.34	4.66	-3.12	-2.06	-20.31	-3.02	-19.35	4.08
		113	14.67	-1.87	-4.43	-3.13	-3.16	1.28	59.60	-0.76	-0.41	59.25	4.57
		119	6.94	-0.01	-1.74	-0.04	-1.72	0.22	-4.18	-29.94	-15.42	-18.71	12.77
		117	6.49	2.11	0.39	0.79	1.71	0.72	24.97	-1.44	13.42	10.10	13.10
96	3	108	6.13	8.64	2.19	5.47	5.37	-3.23	-5.75	-23.34	-6.05	-23.04	2.28
		113	15.99	-1.52	-4.59	-2.37	-3.74	1.38	62.39	-4.67	-4.15	61.87	5.90
		119	7.54	0.93	-2.25	0.92	-2.24	0.11	-1.47	-31.62	-16.53	-16.56	15.08
		117	6.00	2.71	1.40	1.78	2.32	0.60	22.09	-2.68	12.15	7.25	12.14
96	35	108	5.95	8.23	1.74	4.91	5.06	-3.25	-3.55	-21.90	-4.15	-21.30	3.26
		113	15.29	-1.85	-4.55	-2.92	-3.48	1.32	60.95	-2.66	-2.25	60.54	5.11
		119	7.21	0.35	-1.99	0.34	-1.98	0.16	-3.03	-30.71	-15.85	-17.89	13.80
		117	6.26	2.39	0.83	1.20	2.01	0.67	23.70	-1.87	12.83	9.00	12.64
97	1	116	14.45	1.16	-1.12	-1.04	1.07	0.44	-42.44	-68.14	-67.84	-42.74	2.76
		115	15.81	-1.83	-3.21	-2.79	-2.24	-0.63	64.28	-0.28	64.22	-0.22	1.97
		121	9.92	2.01	-0.69	-0.60	1.92	0.47	35.03	-9.89	26.59	-1.44	17.55
		122	9.93	1.14	-2.59	0.16	-1.62	1.64	4.44	-37.69	-29.82	-3.42	16.41
97	2	116	9.68	0.83	-0.81	-0.75	0.77	0.31	-28.12	-45.63	-45.44	-28.31	1.81
		115	10.70	-1.30	-2.31	-2.03	-1.59	-0.45	43.47	-0.12	43.43	-0.08	1.31
		121	6.52	1.43	-0.51	-0.45	1.37	0.35	23.11	-6.30	17.70	-0.90	11.39
		122	6.71	0.82	-1.85	0.11	-1.14	1.18	3.16	-25.30	-19.82	-2.32	11.22

97	18	116	9.67	1.04	-1.31	-1.30	1.02	0.17	-26.61	-45.32	-45.11	-26.82	1.97
		115	11.20	-1.11	-3.19	-2.70	-1.60	-0.88	45.03	-4.52e-03	45.02	7.02e-03	0.72
		121	6.28	1.46	-1.24	-1.24	1.46	-0.03	21.85	-5.24	17.43	-0.83	10.00
		122	6.96	0.26	-1.83	-0.61	-0.96	1.03	4.06	-25.55	-20.29	-1.21	11.32
97	50	116	9.71	0.95	-1.06	-1.03	0.91	0.27	-27.33	-45.70	-45.51	-27.52	1.87
		115	11.05	-1.25	-2.79	-2.42	-1.61	-0.66	44.65	1.54e-03	44.62	0.03	1.05
		121	6.36	1.47	-0.85	-0.82	1.45	0.23	22.49	-5.63	17.67	-0.81	10.60
		122	6.89	0.61	-1.88	-0.19	-1.07	1.17	3.63	-25.60	-20.05	-1.91	11.46
98	1	114	14.56	-1.28	-2.15	-1.64	-1.79	0.43	59.51	-0.98	59.42	-0.89	-2.34
		116	14.10	0.71	-0.86	-0.82	0.66	-0.26	-43.30	-66.26	-66.00	-43.56	-2.43
		122	9.37	0.38	-2.39	-0.09	-1.92	-1.04	3.56	-36.49	-29.80	-3.13	-14.94
		120	10.39	1.91	-0.33	-0.33	1.91	0.03	35.85	-11.14	26.12	-1.42	-19.03
98	2	114	9.76	-0.91	-1.52	-1.16	-1.28	0.30	39.89	-0.64	39.83	-0.58	-1.59
		116	9.41	0.51	-0.62	-0.59	0.47	-0.18	-28.76	-44.22	-44.06	-28.92	-1.56
		122	6.28	0.26	-1.70	-0.07	-1.37	-0.74	2.49	-24.37	-19.79	-2.10	-10.11
		120	6.86	1.36	-0.24	-0.24	1.35	0.03	23.69	-7.25	17.32	-0.89	-12.50
98	9	114	9.27	-0.63	-1.09	-0.63	-1.08	0.05	38.78	0.49	38.72	0.55	-1.58
		116	9.64	0.39	-0.12	-0.10	0.36	-0.10	-30.53	-45.46	-45.32	-30.67	-1.44
		122	6.52	1.12	-1.83	0.87	-1.58	-0.82	1.35	-26.36	-20.95	-4.05	-10.98
		120	6.77	1.79	0.64	0.74	1.69	-0.31	23.61	-7.12	16.12	0.37	-13.19
98	41	114	9.57	-0.85	-1.35	-0.96	-1.25	0.20	39.48	-0.19	39.41	-0.13	-1.60
		116	9.51	0.48	-0.45	-0.42	0.45	-0.15	-29.42	-44.76	-44.62	-29.56	-1.47
		122	6.39	0.58	-1.78	0.29	-1.49	-0.78	2.01	-25.22	-20.27	-2.95	-10.51
		120	6.73	1.53	0.15	0.16	1.53	-0.08	23.58	-7.09	16.80	-0.31	-12.72
99	1	126	11.89	-2.92	-6.12	-3.77	-5.27	-1.41	47.28	0.40	1.34	46.34	-6.57
		111	4.69	8.07	3.02	5.31	5.78	2.51	-0.43	-14.11	-6.34	-8.20	-6.78
		123	11.24	-2.36	-5.94	-4.67	-3.63	-1.71	45.92	2.20	44.82	3.30	-6.84
		124	11.86	0.64	0.28	0.30	0.62	-0.08	-36.19	-55.91	-45.66	-46.45	-9.85
99	2	126	7.99	-2.10	-4.31	-2.70	-3.71	-0.98	31.74	0.31	0.94	31.11	-4.39
		111	3.17	5.73	2.13	3.78	4.09	1.80	-0.83	-9.54	-4.50	-5.87	-4.30
		123	7.56	-1.66	-4.22	-3.32	-2.55	-1.22	30.89	1.71	30.16	2.44	-4.55
		124	7.93	0.46	0.19	0.20	0.45	-0.05	-24.04	-37.38	-30.48	-30.95	-6.66
99	29	126	7.84	-1.92	-4.17	-2.43	-3.67	-0.94	30.20	-1.42	-0.87	29.65	-4.14
		111	3.69	6.58	2.58	4.41	4.75	1.99	-4.69	-12.31	-6.30	-10.70	-3.11
		123	8.02	-1.49	-3.78	-3.04	-2.23	-1.07	30.89	-2.59	30.12	-1.82	-5.01
		124	8.40	0.76	0.55	0.60	0.71	0.09	-23.65	-39.50	-30.71	-32.45	-7.88
99	61	126	7.96	-2.14	-4.34	-2.69	-3.79	-0.95	31.16	-0.48	0.12	30.56	-4.31
		111	3.37	6.27	2.36	4.15	4.48	1.95	-2.77	-10.65	-5.31	-8.10	-3.69
		123	7.76	-1.64	-4.15	-3.30	-2.49	-1.18	30.99	0.03	30.25	0.78	-4.75
		124	8.12	0.59	0.34	0.34	0.59	2.35e-03	-23.86	-38.27	-30.58	-31.54	-7.19
100	1	105	5.21	9.23	3.70	7.50	5.43	-2.56	-3.24	-16.48	-11.62	-8.10	6.38
		126	10.90	-2.28	-7.09	-4.61	-4.76	2.40	45.94	4.66	5.94	44.66	7.16
		124	12.35	0.85	0.66	0.69	0.83	0.06	-36.18	-58.21	-49.11	-45.28	10.85
		125	13.07	-2.31	-8.51	-7.12	-3.70	2.59	51.96	3.08	51.29	3.75	5.68
100	2	105	3.60	6.63	2.62	5.43	3.82	-1.84	-2.94	-11.38	-8.50	-5.82	4.00
		126	7.26	-1.61	-5.06	-3.33	-3.33	1.73	30.74	3.54	4.42	29.85	4.83
		124	8.30	0.61	0.48	0.49	0.61	0.03	-24.01	-39.15	-33.09	-30.07	7.42
		125	8.95	-1.60	-6.16	-5.16	-2.59	1.89	35.45	2.37	35.03	2.79	3.68
100	9	105	3.47	6.39	2.65	4.89	4.16	-1.83	-4.73	-11.33	-9.53	-6.53	2.94
		126	7.28	-1.82	-5.87	-4.73	-2.97	1.82	31.60	4.06	4.89	30.77	4.71
		124	8.21	1.09	-0.97	-0.96	1.09	0.10	-22.37	-39.13	-32.83	-28.68	8.12
		125	9.84	-1.45	-8.16	-7.18	-2.42	2.36	37.42	2.40	37.09	2.73	3.38
100	41	105	3.64	6.82	2.73	5.51	4.03	-1.91	-4.13	-11.66	-9.47	-6.32	3.42
		126	7.22	-1.76	-5.56	-4.10	-3.21	1.85	31.02	4.04	4.95	30.11	4.86
		124	8.28	0.85	-0.10	-0.09	0.84	0.06	-23.24	-39.41	-33.31	-29.33	7.84
		125	9.52	-1.54	-7.33	-6.31	-2.55	2.20	36.95	2.59	36.60	2.94	3.44

101	1	124	11.86	0.64	0.28	0.30	0.62	0.08	-36.19	-55.91	-45.66	-46.45	9.85
		123	11.24	-2.36	-5.94	-4.67	-3.63	1.71	45.92	2.20	44.82	3.30	6.84
		110	4.69	8.07	3.02	5.31	5.78	-2.51	-0.43	-14.11	-6.34	-8.20	6.78
		127	11.89	-2.92	-6.12	-3.77	-5.27	1.41	47.28	0.40	1.34	46.34	6.57
101	2	124	7.93	0.46	0.19	0.20	0.45	0.05	-24.04	-37.38	-30.48	-30.95	6.66
		123	7.56	-1.66	-4.22	-3.32	-2.55	1.22	30.89	1.71	30.16	2.44	4.55
		110	3.17	5.73	2.13	3.78	4.09	-1.80	-0.83	-9.54	-4.50	-5.87	4.30
		127	7.99	-2.10	-4.31	-2.70	-3.71	0.98	31.74	0.31	0.94	31.11	4.39
101	29	124	7.65	0.65	-0.09	0.60	-0.04	0.19	-24.55	-35.83	-30.71	-29.66	5.62
		123	7.10	-1.68	-4.43	-3.04	-3.07	1.38	30.84	6.09	30.12	6.80	4.15
		110	3.16	5.83	2.36	4.28	3.91	-1.72	2.53	-8.01	-3.41	-2.08	5.23
		127	8.37	-1.98	-4.99	-2.55	-4.42	1.17	33.19	1.27	2.02	32.43	4.85
101	61	124	7.81	0.43	0.19	0.34	0.28	0.12	-24.23	-36.72	-30.58	-30.37	6.24
		123	7.37	-1.74	-4.40	-3.30	-2.85	1.31	30.97	3.65	30.25	4.38	4.39
		110	3.14	5.95	2.28	4.10	4.13	-1.84	0.27	-8.88	-4.11	-4.50	4.57
		127	8.18	-2.16	-4.68	-2.74	-4.10	1.05	32.40	0.64	1.32	31.72	4.60
102	1	125	13.07	-2.31	-8.51	-7.12	-3.70	-2.59	51.96	3.08	51.29	3.75	-5.68
		124	12.35	0.85	0.66	0.69	0.83	-0.06	-36.18	-58.21	-49.11	-45.28	-10.85
		127	10.90	-2.28	-7.09	-4.61	-4.76	-2.40	45.94	4.66	5.94	44.66	-7.16
		109	5.21	9.23	3.70	7.50	5.43	2.56	-3.24	-16.48	-11.62	-8.10	-6.38
102	2	125	8.95	-1.60	-6.16	-5.16	-2.59	-1.89	35.45	2.37	35.03	2.79	-3.68
		124	8.30	0.61	0.48	0.49	0.61	-0.03	-24.01	-39.15	-33.09	-30.07	-7.42
		127	7.26	-1.61	-5.06	-3.33	-3.33	-1.73	30.74	3.54	4.42	29.85	-4.83
		109	3.60	6.63	2.62	5.43	3.82	1.84	-2.94	-11.38	-8.50	-5.82	-4.00
102	16	125	8.78	-1.54	-5.52	-4.21	-2.85	-1.87	35.82	2.94	35.42	3.33	-3.59
		124	8.68	2.01	0.19	2.01	0.19	0.03	-25.05	-40.17	-34.50	-30.72	-7.32
		127	7.15	-1.09	-5.21	-2.43	-3.86	-1.93	29.82	3.68	4.78	28.72	-5.24
		109	4.12	8.09	2.83	7.18	3.74	1.99	-3.01	-12.56	-9.65	-5.92	-4.40
102	48	125	9.08	-1.59	-6.22	-5.08	-2.73	-2.00	36.28	2.81	35.91	3.19	-3.53
		124	8.51	1.14	0.47	1.14	0.47	-2.20e-03	-24.35	-39.84	-34.01	-30.18	-7.50
		127	7.16	-1.46	-5.27	-3.15	-3.59	-1.89	30.28	3.89	4.90	29.26	-5.08
		109	3.92	7.53	2.80	6.47	3.86	1.97	-3.41	-12.17	-9.52	-6.07	-4.03
103	1	105	7.95	3.42	-23.64	-12.81	-7.41	13.26	-7.99	-24.66	-7.99	-24.66	0.13
		126	7.92	1.39	-8.93	-8.35	0.82	2.37	7.08	-22.14	6.05	-21.11	-5.37
		89	13.48	22.43	7.73	9.51	20.65	-4.79	45.19	5.20	5.86	44.53	5.09
		90	15.64	2.18	-22.64	2.18	-22.63	-0.32	41.29	-7.30	-7.29	41.29	-0.51
103	2	105	5.70	2.79	-17.28	-9.28	-5.21	9.83	-5.91	-17.22	-5.91	-17.21	0.13
		126	5.58	1.27	-6.29	-6.01	0.98	1.44	5.21	-15.14	4.43	-14.36	-3.90
		89	9.49	16.28	5.70	6.87	15.11	-3.32	31.44	3.74	4.25	30.93	3.71
		90	10.96	1.62	-15.75	1.61	-15.74	-0.44	28.83	-5.35	-5.35	28.82	-0.41
103	29	105	6.35	3.52	-19.81	-10.17	-6.11	11.49	-6.60	-16.62	-6.69	-16.54	0.92
		126	6.11	1.15	-6.74	-6.47	0.88	1.43	5.42	-17.10	4.77	-16.45	-3.78
		89	9.18	17.24	6.12	7.20	16.15	-3.29	29.42	4.16	4.61	28.97	3.35
		90	11.39	1.50	-16.71	1.49	-16.70	-0.39	29.65	-5.85	-5.77	29.57	-1.68
103	61	105	6.25	3.58	-19.51	-10.22	-5.71	11.32	-6.64	-17.01	-6.68	-16.97	0.64
		126	5.95	1.49	-6.71	-6.52	1.29	1.26	5.59	-16.02	4.78	-15.22	-4.10
		89	9.54	17.72	6.28	7.44	16.56	-3.46	30.75	3.99	4.54	30.20	3.81
		90	11.23	1.74	-16.31	1.73	-16.30	-0.55	29.17	-5.88	-5.85	29.13	-1.15
104	1	71	2.34	2.38	-5.05	-3.17	0.51	3.23	-0.08	-6.28	-0.09	-6.26	-0.28
		128	0.99	2.00	-2.37	0.20	-0.57	-2.15	1.46	0.16	0.26	1.36	0.35
		126	2.64	6.39	-6.51	-4.60	4.48	4.58	1.89	-0.24	1.14	0.50	-1.02
		105	3.75	4.10	-4.17	3.67	-3.74	-1.84	9.47	-1.37	-1.35	9.45	0.39
104	2	71	1.65	1.69	-3.66	-2.31	0.35	2.32	0.02	-4.37	0.01	-4.37	-0.13
		128	0.74	1.41	-1.68	0.13	-0.40	-1.53	1.17	0.04	0.12	1.08	0.30
		126	1.91	4.45	-4.58	-3.29	3.17	3.16	1.23	-0.52	0.75	-0.03	-0.78
		105	2.60	2.92	-2.80	2.66	-2.53	-1.20	6.60	-0.92	-0.91	6.59	0.23

104	15	71	1.68	1.45	-3.84	-2.87	0.47	2.05	0.08	-4.09	0.06	-4.07	-0.29
		128	0.97	1.92	-2.42	-0.23	-0.27	-2.17	1.87	0.06	0.09	1.84	0.23
		126	1.65	4.66	-3.22	-2.13	3.57	2.72	1.47	-0.17	0.79	0.51	-0.81
		105	2.94	4.71	-2.72	4.34	-2.35	-1.62	7.04	-0.90	-0.89	7.02	0.34
104	47	71	1.72	1.66	-3.97	-2.70	0.39	2.36	0.08	-4.27	0.07	-4.26	-0.20
		128	0.87	1.67	-2.07	-0.05	-0.35	-1.86	1.51	0.03	0.10	1.44	0.31
		126	1.88	4.69	-4.16	-2.96	3.49	3.03	1.35	-0.48	0.76	0.11	-0.86
		105	2.77	3.79	-2.71	3.51	-2.43	-1.31	6.84	-0.93	-0.92	6.83	0.31
105	1	109	7.95	3.42	-23.64	-12.81	-7.41	13.26	24.66	7.99	7.99	24.66	-0.13
		127	7.92	1.39	-8.93	-8.35	0.82	2.37	22.14	-7.08	-6.05	21.11	5.37
		97	13.48	22.43	7.73	9.51	20.65	-4.79	-5.20	-45.19	-5.86	-44.53	-5.09
		98	15.64	2.18	-22.64	2.18	-22.63	-0.32	7.30	-41.29	7.29	-41.29	0.51
105	2	109	5.70	2.79	-17.28	-9.28	-5.21	9.83	17.22	5.91	5.91	17.21	-0.13
		127	5.58	1.27	-6.29	-6.01	0.98	1.44	15.14	-5.21	-4.43	14.36	3.90
		97	9.49	16.28	5.70	6.87	15.11	-3.32	-3.74	-31.44	-4.25	-30.93	-3.71
		98	10.96	1.62	-15.75	1.61	-15.74	-0.44	5.35	-28.83	5.35	-28.82	0.41
105	31	109	6.35	3.52	-19.81	-10.17	-6.11	11.49	16.62	6.60	6.69	16.54	-0.92
		127	6.11	1.15	-6.74	-6.47	0.88	1.43	17.10	-5.42	-4.77	16.45	3.78
		97	9.18	17.24	6.12	7.20	16.15	-3.29	-4.16	-29.42	-4.61	-28.97	-3.35
		98	11.39	1.50	-16.71	1.49	-16.70	-0.39	5.85	-29.65	5.77	-29.57	1.68
105	63	109	6.25	3.58	-19.51	-10.22	-5.71	11.32	17.01	6.64	6.68	16.97	-0.64
		127	5.95	1.49	-6.71	-6.52	1.29	1.26	16.02	-5.59	-4.78	15.22	4.10
		97	9.54	17.72	6.28	7.44	16.56	-3.46	-3.99	-30.75	-4.54	-30.20	-3.81
		98	11.23	1.74	-16.31	1.73	-16.30	-0.55	5.88	-29.17	5.85	-29.13	1.15
106	1	75	2.34	2.38	-5.05	-3.17	0.51	3.23	6.28	0.08	0.09	6.26	0.28
		129	0.99	2.00	-2.37	0.20	-0.57	-2.15	-0.16	-1.46	-0.26	-1.36	-0.35
		127	2.64	6.39	-6.51	-4.60	4.48	4.58	0.24	-1.89	-1.14	-0.50	1.02
		109	3.75	4.10	-4.17	3.67	-3.74	-1.84	1.37	-9.47	1.35	-9.45	-0.39
106	2	75	1.65	1.69	-3.66	-2.31	0.35	2.32	4.37	-0.02	-0.01	4.37	0.13
		129	0.74	1.41	-1.68	0.13	-0.40	-1.53	-0.04	-1.17	-0.12	-1.08	-0.30
		127	1.91	4.45	-4.58	-3.29	3.17	3.16	0.52	-1.23	-0.75	0.03	0.78
		109	2.60	2.92	-2.80	2.66	-2.53	-1.20	0.92	-6.60	0.91	-6.59	-0.23
106	13	75	1.68	1.45	-3.84	-2.87	0.47	2.05	4.09	-0.08	-0.06	4.07	0.29
		129	0.97	1.92	-2.42	-0.23	-0.27	-2.17	-0.06	-1.87	-0.09	-1.84	-0.23
		127	1.65	4.66	-3.22	-2.13	3.57	2.72	0.17	-1.47	-0.79	-0.51	0.81
		109	2.94	4.71	-2.72	4.34	-2.35	-1.62	0.90	-7.04	0.89	-7.02	-0.34
106	45	75	1.72	1.66	-3.97	-2.70	0.39	2.36	4.27	-0.08	-0.07	4.26	0.20
		129	0.87	1.67	-2.07	-0.05	-0.35	-1.86	-0.03	-1.51	-0.10	-1.44	-0.31
		127	1.88	4.69	-4.16	-2.96	3.49	3.03	0.48	-1.35	-0.76	-0.11	0.86
		109	2.77	3.79	-2.71	3.51	-2.43	-1.31	0.93	-6.84	0.92	-6.83	-0.31
107	1	111	3.64	3.48	-4.79	2.87	-4.18	2.16	1.16	-9.21	1.16	-9.21	0.18
		123	2.24	5.80	-5.89	-3.93	3.84	-4.36	-0.46	-1.69	-1.11	-1.04	-0.61
		130	0.78	1.83	-2.00	0.41	-0.58	1.85	-0.30	-1.09	-0.32	-1.07	0.11
		73	2.03	1.98	-3.71	-2.36	0.62	-2.42	6.04	0.32	0.33	6.03	-0.24
107	2	111	2.54	2.46	-3.34	2.02	-2.90	1.54	0.75	-6.49	0.75	-6.49	0.02
		123	1.61	3.91	-4.09	-2.76	2.59	-2.98	0.04	-1.03	-0.71	-0.27	-0.49
		130	0.59	1.32	-1.36	0.36	-0.40	1.28	-0.12	-0.92	-0.14	-0.90	0.13
		73	1.42	1.35	-2.56	-1.65	0.44	-1.65	4.26	0.16	0.17	4.26	-0.09
107	9	111	2.26	2.31	-3.54	1.85	-3.08	1.57	0.72	-5.20	0.72	-5.20	0.01
		123	1.92	3.97	-4.54	-3.18	2.61	-3.12	1.44	-0.80	-0.69	1.32	-0.49
		130	0.52	1.50	-1.26	0.67	-0.44	1.26	0.38	-0.18	-0.11	0.32	0.17
		73	1.79	1.48	-2.54	-1.51	0.45	-1.75	5.96	0.11	0.11	5.96	-0.02
107	41	111	2.48	2.48	-3.54	2.01	-3.08	1.61	0.73	-6.10	0.73	-6.10	-0.02
		123	1.78	3.98	-4.37	-3.02	2.62	-3.08	0.74	-0.88	-0.69	0.55	-0.52
		130	0.58	1.45	-1.33	0.55	-0.43	1.30	-0.03	-0.52	-0.10	-0.45	0.17
		73	1.60	1.42	-2.60	-1.64	0.46	-1.71	5.06	0.12	0.12	5.06	-0.03

108	1	88	16.02	0.92	-23.86	0.92	-23.86	-0.03	5.39	-43.59	5.39	-43.59	-0.33
		35	11.61	16.28	7.08	7.58	15.77	2.09	-4.88	-40.14	-5.16	-39.87	3.08
		123	6.69	0.95	-8.64	-7.04	-0.64	-3.57	20.10	-4.58	-4.05	19.57	-3.56
		111	7.39	1.44	-17.64	-9.10	-7.10	-9.48	25.78	4.56	4.56	25.78	-0.14
108	2	88	11.40	0.62	-16.89	0.62	-16.89	0.09	3.86	-31.08	3.86	-31.08	-0.14
		35	8.23	11.55	4.97	5.26	11.26	1.35	-3.53	-28.39	-3.73	-28.20	2.21
		123	4.67	0.71	-5.98	-4.98	-0.30	-2.39	13.83	-3.30	-2.91	13.44	-2.56
		111	5.22	1.07	-12.43	-6.40	-4.96	-6.71	18.33	3.24	3.25	18.32	-0.21
108	3	88	12.85	0.14	-19.20	0.14	-19.20	-6.76e-03	4.70	-34.99	4.70	-34.99	0.03
		35	9.00	11.29	4.83	5.05	11.07	1.18	-3.12	-31.56	-3.28	-31.39	2.15
		123	4.24	-0.05	-6.52	-5.29	-1.28	-2.54	11.81	-3.65	-3.09	11.26	-2.88
		111	5.29	0.72	-13.73	-6.64	-6.36	-7.22	16.97	3.26	3.26	16.97	-0.02
108	35	88	12.39	0.42	-18.54	0.42	-18.54	0.06	4.32	-33.68	4.32	-33.68	-0.11
		35	8.76	11.96	5.09	5.33	11.72	1.24	-3.47	-30.21	-3.66	-30.02	2.23
		123	4.57	0.44	-6.37	-5.31	-0.63	-2.47	13.10	-3.52	-3.04	12.63	-2.76
		111	5.41	0.98	-13.36	-6.67	-5.71	-7.15	18.29	3.31	3.31	18.29	-0.13
109	1	105	4.63	3.14	-4.93	2.53	-4.33	2.13	14.12	-1.02	-0.88	13.99	1.44
		125	3.29	5.62	-6.28	-4.33	3.67	-4.41	1.26	-4.93	1.05	-4.71	1.14
		131	1.45	1.82	-1.82	0.71	-0.70	1.68	3.98	-0.45	-0.40	3.93	-0.50
		71	2.75	1.74	-2.97	-1.99	0.76	-1.91	0.33	-9.74	0.26	-9.68	-0.81
109	2	105	3.30	2.22	-3.46	1.77	-3.01	1.53	10.24	-0.67	-0.54	10.11	1.19
		125	2.42	3.77	-4.39	-3.05	2.44	-3.02	0.83	-4.22	0.67	-4.06	0.88
		131	1.12	1.33	-1.23	0.59	-0.49	1.16	3.10	-0.45	-0.39	3.05	-0.42
		71	1.99	1.18	-2.01	-1.38	0.54	-1.27	0.35	-7.09	0.28	-7.02	-0.71
109	9	105	3.55	2.66	-3.67	2.02	-3.03	1.91	11.32	-0.79	-0.50	11.04	1.85
		125	2.99	3.67	-4.23	-2.94	2.39	-2.91	0.85	-6.97	0.60	-6.72	1.37
		131	1.15	1.67	-1.27	0.81	-0.41	1.34	2.41	-0.84	-0.55	2.12	-0.92
		71	2.24	1.12	-1.78	-1.34	0.68	-1.03	0.62	-8.09	0.41	-7.88	-1.34
109	41	105	3.55	2.48	-3.68	1.89	-3.09	1.82	11.33	-0.71	-0.48	11.10	1.65
		125	2.80	3.67	-4.41	-3.07	2.33	-3.00	0.82	-6.06	0.61	-5.85	1.16
		131	1.22	1.56	-1.23	0.79	-0.47	1.25	3.12	-0.69	-0.56	2.99	-0.69
		71	2.21	1.13	-1.86	-1.36	0.63	-1.12	0.55	-7.97	0.41	-7.82	-1.10
110	1	90	22.10	0.02	-26.12	-0.13	-25.97	-2.00	67.49	-6.46	-6.05	67.08	-5.50
		38	17.96	17.16	6.50	7.79	15.87	3.47	67.71	6.94	7.15	67.49	-3.60
		125	8.86	1.47	-10.53	-8.04	-1.02	-4.87	6.53	-27.24	5.98	-26.68	4.28
		105	9.87	-0.76	-15.00	-8.26	-7.50	-7.11	-3.39	-39.96	-4.11	-39.25	5.05
110	2	90	16.00	-0.08	-18.59	-0.16	-18.51	-1.20	49.11	-4.70	-4.36	48.78	-4.21
		38	12.99	12.04	4.66	5.38	11.32	2.19	49.02	5.08	5.23	48.87	-2.60
		125	6.28	0.98	-7.31	-5.70	-0.62	-3.27	4.77	-19.16	4.36	-18.75	3.10
		105	7.14	-0.49	-10.49	-5.75	-5.23	-4.99	-2.34	-29.07	-2.92	-28.49	3.88
110	9	90	18.02	-1.01	-20.74	-1.06	-20.69	-0.97	55.94	-5.13	-4.66	55.46	-5.36
		38	14.65	11.32	3.83	4.52	10.63	2.16	56.48	5.54	5.70	56.32	-2.84
		125	6.01	0.06	-7.51	-5.70	-1.75	-3.23	5.28	-18.31	4.73	-17.76	3.56
		105	7.76	-1.22	-10.71	-5.59	-6.34	-4.73	-2.17	-30.96	-2.97	-30.16	4.72
110	41	90	17.75	-0.55	-20.20	-0.61	-20.14	-1.03	55.11	-5.08	-4.63	54.66	-5.17
		38	14.40	11.83	4.33	4.97	11.19	2.10	55.13	5.56	5.72	54.97	-2.80
		125	6.39	0.51	-7.54	-5.83	-1.20	-3.29	5.23	-19.59	4.74	-19.10	3.43
		105	7.84	-0.97	-10.54	-5.72	-5.79	-4.79	-2.19	-31.73	-2.96	-30.97	4.69
111	1	128	0.70	-0.55	-1.41	-1.02	-0.94	-0.43	2.21	0.56	0.80	1.97	0.58
		73	0.93	2.08	0.48	1.19	1.36	0.79	-1.99	-3.42	-2.23	-3.17	0.54
		130	0.69	-0.34	-1.22	-0.85	-0.71	-0.44	2.30	1.05	1.57	1.79	0.62
		132	0.62	0.32	0.09	0.32	0.09	-0.03	1.08	-1.84	-0.20	-0.55	-1.45
111	2	128	0.47	-0.42	-1.00	-0.76	-0.65	-0.29	1.49	0.37	0.51	1.35	0.38
		73	0.66	1.45	0.35	0.83	0.96	0.55	-1.38	-2.40	-1.55	-2.24	0.38
		130	0.47	-0.20	-0.83	-0.58	-0.45	-0.31	1.59	0.75	1.07	1.27	0.41
		132	0.43	0.26	0.04	0.25	0.04	-0.03	0.73	-1.27	-0.15	-0.39	-0.99

111	25	128	0.42	-0.57	-0.73	-0.71	-0.60	-0.06	0.47	-1.26	-0.97	0.18	0.65
		73	1.54	1.91	0.39	1.03	1.28	0.75	-2.47	-6.65	-2.93	-6.19	1.31
		130	0.79	-0.14	-0.55	-0.53	-0.15	-0.08	0.91	-2.51	0.91	-2.51	-0.01
		132	1.00	0.56	-0.08	0.37	0.10	0.29	1.16	-3.08	-0.31	-1.61	-2.02
111	57	128	0.40	-0.52	-0.93	-0.80	-0.65	-0.19	1.07	-0.34	-0.15	0.88	0.48
		73	1.03	1.68	0.38	0.93	1.13	0.64	-1.83	-4.24	-2.12	-3.95	0.79
		130	0.40	-0.18	-0.69	-0.57	-0.30	-0.22	1.04	-0.31	1.01	-0.27	0.23
		132	0.66	0.37	0.02	0.34	0.05	0.10	0.91	-2.03	-0.22	-0.90	-1.43
112	1	131	0.86	-0.05	-1.28	-0.95	-0.38	-0.54	2.97	1.26	2.52	1.71	0.76
		132	0.74	0.48	0.01	0.48	0.01	0.01	0.81	-2.40	-1.22	-0.38	-1.55
		129	0.89	-0.70	-1.48	-1.31	-0.87	-0.32	3.07	1.37	2.81	1.62	0.60
		75	1.25	2.27	0.58	1.58	1.27	0.83	-2.77	-4.68	-4.57	-2.87	0.44
112	2	131	0.60	0.03	-0.88	-0.66	-0.19	-0.39	2.09	0.91	1.79	1.21	0.51
		132	0.52	0.38	-0.02	0.38	-0.02	4.72e-03	0.53	-1.70	-0.92	-0.26	-1.07
		129	0.64	-0.51	-1.06	-0.97	-0.61	-0.21	2.18	0.95	2.04	1.09	0.39
		75	0.90	1.59	0.42	1.12	0.89	0.57	-1.95	-3.39	-3.32	-2.02	0.30
112	25	131	0.57	0.15	-0.77	-0.62	8.59e-04	-0.34	1.90	0.53	1.74	0.69	0.44
		132	0.93	0.56	-0.19	0.54	-0.17	0.12	1.63	-2.33	-1.29	0.60	-1.74
		129	0.58	-0.55	-1.16	-1.00	-0.71	-0.27	2.01	0.70	0.83	1.88	0.39
		75	1.32	1.71	0.60	1.35	0.97	0.52	-2.35	-5.43	-5.12	-2.67	0.93
112	57	131	0.61	0.17	-0.84	-0.65	-0.02	-0.39	2.10	0.80	1.87	1.03	0.49
		132	0.72	0.51	-0.12	0.50	-0.12	0.05	0.99	-2.04	-1.17	0.12	-1.37
		129	0.60	-0.57	-1.18	-1.08	-0.66	-0.22	1.93	1.13	1.66	1.40	0.38
		75	1.11	1.69	0.52	1.26	0.95	0.56	-2.17	-4.44	-4.28	-2.32	0.57
113	1	71	1.25	2.27	0.58	1.58	1.27	-0.83	-2.77	-4.68	-4.57	-2.87	-0.44
		128	0.89	-0.70	-1.48	-1.31	-0.87	0.32	3.07	1.37	2.81	1.62	-0.60
		132	0.74	0.48	0.01	0.48	0.01	-0.01	0.81	-2.40	-1.22	-0.38	1.55
		131	0.86	-0.05	-1.28	-0.95	-0.38	0.54	2.97	1.26	2.52	1.71	-0.76
113	2	71	0.90	1.59	0.42	1.12	0.89	-0.57	-1.95	-3.39	-3.32	-2.02	-0.30
		128	0.64	-0.51	-1.06	-0.97	-0.61	0.21	2.18	0.95	2.04	1.09	-0.39
		132	0.52	0.38	-0.02	0.38	-0.02	-4.72e-03	0.53	-1.70	-0.92	-0.26	1.07
		131	0.60	0.03	-0.88	-0.66	-0.19	0.39	2.09	0.91	1.79	1.21	-0.51
113	31	71	0.76	1.64	0.32	1.05	0.90	-0.66	-1.38	-2.36	-2.25	-1.49	0.30
		128	1.09	-0.53	-1.30	-1.29	-0.54	0.08	3.72	0.19	3.69	0.22	-0.34
		132	0.32	0.44	-0.02	0.41	7.65e-04	0.11	-0.48	-1.44	-0.87	-1.06	0.47
		131	0.74	0.20	-1.02	-0.74	-0.07	0.51	2.67	1.37	2.17	1.87	-0.63
113	63	71	0.87	1.66	0.40	1.14	0.92	-0.62	-1.83	-3.09	-3.09	-1.83	-0.05
		128	0.84	-0.56	-1.24	-1.21	-0.59	0.14	2.91	0.65	2.86	0.71	-0.36
		132	0.44	0.45	-0.05	0.45	-0.05	0.04	0.08	-1.65	-0.99	-0.58	0.84
		131	0.68	0.19	-0.95	-0.71	-0.05	0.46	2.42	1.15	2.05	1.52	-0.57
114	1	104	5.84	3.25	-5.78	1.54	-4.07	3.54	5.13	-17.23	5.00	-17.10	-1.70
		118	1.50	1.22	-1.40	0.45	-0.63	-1.20	-0.45	-6.05	-0.66	-5.84	1.06
		133	1.71	0.20	-1.35	-1.22	0.07	0.43	3.80	-3.71	-3.28	3.37	-1.74
		77	3.28	1.76	-4.65	-2.70	-0.20	-2.95	13.60	6.08	6.39	13.29	1.51
114	2	104	4.19	2.37	-4.08	1.10	-2.81	2.56	3.41	-12.63	3.31	-12.54	-1.22
		118	1.06	0.82	-0.99	0.36	-0.53	-0.79	-0.46	-4.13	-0.52	-4.06	0.48
		133	1.21	0.18	-0.94	-0.84	0.09	0.32	2.63	-2.60	-2.41	2.44	-0.98
		77	2.36	1.23	-3.24	-1.89	-0.12	-2.05	9.95	4.10	4.31	9.75	1.08
114	6	104	4.19	2.34	-4.41	1.09	-3.15	2.62	3.37	-11.71	3.36	-11.70	0.38
		118	1.35	0.84	-1.46	0.37	-0.98	-0.93	0.19	-5.19	-0.59	-4.41	1.89
		133	1.58	-0.06	-0.81	-0.79	-0.08	0.12	3.46	-3.80	-2.72	2.38	-2.59
		77	3.09	1.28	-3.52	-1.94	-0.30	-2.25	13.53	4.24	4.29	13.49	-0.65
114	38	104	4.41	2.50	-4.41	1.10	-3.02	2.78	3.34	-13.15	3.32	-13.13	-0.64
		118	1.16	0.76	-1.22	0.38	-0.85	-0.78	-0.42	-4.48	-0.63	-4.28	0.89
		133	1.34	0.14	-0.86	-0.78	0.06	0.27	2.92	-3.10	-2.69	2.51	-1.51
		77	2.69	1.24	-3.32	-1.92	-0.16	-2.10	12.08	4.29	4.31	12.06	0.41

115	1	18	23.28	-1.16	-39.81	-1.51	-39.45	-3.69	14.58	-57.77	13.73	-56.92	7.79
		91	14.08	6.58	1.46	2.01	6.04	1.57	-11.22	-59.83	-13.31	-57.74	9.87
		118	12.22	0.18	-20.00	-6.61	-13.21	-9.53	33.10	-21.76	-19.74	31.08	-10.32
		104	8.52	-1.55	-6.00	-5.10	-2.45	-1.79	39.50	13.56	15.85	37.21	-7.37
115	2	18	16.84	-0.88	-28.32	-1.10	-28.10	-2.45	10.78	-42.00	10.15	-41.37	5.74
		91	10.30	4.62	1.11	1.36	4.36	0.91	-7.94	-43.61	-9.58	-41.97	7.48
		118	8.79	-0.07	-13.89	-4.72	-9.23	-6.53	24.01	-15.86	-14.27	22.42	-7.80
		104	6.19	-1.02	-4.24	-3.62	-1.64	-1.27	28.83	9.97	11.68	27.12	-5.42
115	31	18	18.46	-1.21	-29.80	-1.37	-29.65	-2.11	11.92	-47.10	11.01	-46.18	7.28
		91	11.72	4.36	0.76	1.01	4.10	0.92	-8.50	-50.02	-10.70	-47.82	9.31
		118	9.69	-0.34	-13.89	-4.74	-9.49	-6.34	25.90	-18.05	-15.68	23.53	-9.92
		104	7.06	-1.21	-3.95	-3.66	-1.50	-0.85	32.71	10.15	12.77	30.09	-7.23
115	63	18	18.45	-1.10	-29.87	-1.27	-29.70	-2.18	11.93	-46.90	11.11	-46.08	6.92
		91	11.53	4.28	0.88	1.11	4.05	0.85	-8.54	-49.23	-10.61	-47.17	8.94
		118	9.66	-0.31	-14.00	-4.77	-9.54	-6.41	26.29	-17.78	-15.68	24.19	-9.40
		104	6.99	-1.22	-4.02	-3.68	-1.55	-0.91	32.47	10.50	12.77	30.20	-6.69
116	1	118	2.02	-0.42	-2.68	-0.44	-2.67	0.19	-1.00	-6.81	-1.21	-6.60	1.08
		115	2.83	4.85	-4.10	-3.16	3.91	-2.75	-0.37	-6.41	-0.38	-6.40	0.20
		134	0.71	0.77	-1.89	-0.13	-0.99	1.26	1.04	-0.72	-0.72	1.04	-0.05
		133	1.58	2.02	-1.41	-0.66	1.28	-1.41	3.99	-0.39	0.31	3.29	-1.60
116	2	118	1.34	-0.29	-1.90	-0.30	-1.89	0.13	-0.81	-4.47	-0.87	-4.41	0.46
		115	1.78	3.30	-2.88	-2.24	2.66	-1.88	-0.15	-3.56	-0.15	-3.56	0.12
		134	0.42	0.57	-1.29	-0.02	-0.69	0.87	0.40	-0.39	-0.39	0.40	-0.02
		133	1.00	1.37	-0.92	-0.43	0.88	-0.94	2.58	-0.08	0.22	2.28	-0.85
116	9	118	1.33	-0.40	-1.95	-0.40	-1.95	0.02	-0.83	-4.47	-1.02	-4.28	0.81
		115	2.12	3.42	-3.20	-2.41	2.62	-2.15	0.07	-4.40	-0.10	-4.24	0.84
		134	0.56	0.44	-1.00	0.03	-0.59	0.65	0.05	-1.84	-0.25	-1.54	-0.69
		133	1.21	1.58	-1.06	-0.45	0.98	-1.11	3.03	-0.33	0.27	2.42	-1.29
116	41	118	1.33	-0.34	-2.02	-0.35	-2.00	0.16	-0.93	-4.37	-0.98	-4.32	0.41
		115	1.81	3.28	-3.08	-2.36	2.57	-2.01	5.90e-04	-3.36	-0.05	-3.31	0.42
		134	0.40	0.60	-1.15	0.11	-0.65	0.79	-0.10	-0.77	-0.26	-0.61	-0.29
		133	1.03	1.44	-0.90	-0.38	0.92	-0.97	2.69	-0.05	0.27	2.38	-0.87
117	1	91	14.79	3.11	-2.36	2.95	-2.21	0.91	-7.64	-62.19	-7.64	-62.18	0.43
		39	15.48	6.10	3.80	5.96	3.93	0.55	3.03	-62.15	3.02	-62.14	-0.96
		115	8.47	-1.11	-6.37	-5.92	-1.56	-1.47	35.07	1.91	1.97	35.02	1.34
		118	9.34	0.19	-12.61	-6.94	-5.48	-6.36	34.17	-4.86	-4.83	34.13	-1.15
117	2	91	10.73	2.21	-1.76	2.01	-1.56	0.86	-5.52	-45.14	-5.54	-45.13	0.69
		39	11.24	4.18	2.98	4.17	3.00	0.13	2.04	-45.01	2.03	-45.00	-0.69
		115	5.97	-0.72	-4.45	-4.25	-0.92	-0.84	24.49	1.25	1.29	24.45	0.96
		118	6.65	0.34	-9.02	-4.90	-3.78	-4.64	24.49	-3.57	-3.52	24.44	-1.21
117	18	91	12.11	1.73	-2.80	1.39	-2.47	1.19	-6.02	-50.55	-6.09	-50.48	1.76
		39	12.84	3.67	2.56	3.64	2.58	0.16	2.08	-51.80	2.08	-51.80	-0.23
		115	5.87	-1.36	-4.43	-4.32	-1.47	-0.57	24.44	1.30	1.31	24.44	0.46
		118	7.22	-0.14	-9.15	-4.87	-4.43	-4.50	26.58	-4.08	-3.89	26.38	-2.44
117	50	91	12.03	1.93	-2.51	1.65	-2.23	1.07	-6.06	-50.33	-6.11	-50.29	1.48
		39	12.62	3.91	2.82	3.91	2.82	0.05	2.07	-50.82	2.06	-50.82	-0.53
		115	6.16	-1.08	-4.53	-4.39	-1.23	-0.68	25.44	1.26	1.28	25.42	0.80
		118	7.23	0.07	-9.19	-4.93	-4.19	-4.61	26.72	-4.06	-3.91	26.57	-2.09
118	1	115	2.83	4.85	-4.10	-3.16	3.91	2.75	-0.37	-6.41	-0.38	-6.40	-0.20
		121	2.02	-0.42	-2.68	-0.44	-2.67	-0.19	-1.00	-6.81	-1.21	-6.60	-1.08
		135	1.58	2.02	-1.41	-0.66	1.28	1.41	3.99	-0.39	0.31	3.29	1.60
		134	0.71	0.77	-1.89	-0.13	-0.99	-1.26	1.04	-0.72	-0.72	1.04	0.05
118	2	115	1.78	3.30	-2.88	-2.24	2.66	1.88	-0.15	-3.56	-0.15	-3.56	-0.12
		121	1.34	-0.29	-1.90	-0.30	-1.89	-0.13	-0.81	-4.47	-0.87	-4.41	-0.46
		135	1.00	1.37	-0.92	-0.43	0.88	0.94	2.58	-0.08	0.22	2.28	0.85
		134	0.42	0.57	-1.29	-0.02	-0.69	-0.87	0.40	-0.39	-0.39	0.40	0.02

118	25	115	1.67	3.13	-2.99	-2.38	2.52	1.83	0.05	-3.13	0.04	-3.13	0.05
		121	1.54	-0.31	-2.12	-0.37	-2.05	-0.34	-0.88	-5.18	-0.88	-5.18	0.02
		135	0.72	1.26	-0.73	-0.34	0.87	0.79	1.67	0.09	0.24	1.52	0.46
		134	0.43	0.78	-1.34	0.14	-0.70	-0.97	-0.25	-0.47	-0.29	-0.43	-0.08
118	57	115	1.63	3.16	-2.99	-2.35	2.52	1.88	7.76e-03	-2.85	7.09e-03	-2.85	-0.04
		121	1.42	-0.29	-2.10	-0.34	-2.05	-0.30	-0.92	-4.70	-0.92	-4.70	-0.06
		135	0.83	1.30	-0.76	-0.33	0.88	0.84	2.15	0.11	0.25	2.00	0.52
		134	0.37	0.75	-1.29	0.15	-0.69	-0.92	-0.14	-0.29	-0.28	-0.15	-0.04
119	1	39	15.48	6.10	3.80	5.96	3.93	-0.55	3.03	-62.15	3.02	-62.14	0.96
		99	14.79	3.11	-2.36	2.95	-2.21	-0.91	-7.64	-62.19	-7.64	-62.18	-0.43
		121	9.34	0.19	-12.61	-6.94	-5.48	6.36	34.17	-4.86	-4.83	34.13	1.15
		115	8.47	-1.11	-6.37	-5.92	-1.56	1.47	35.07	1.91	1.97	35.02	-1.34
119	2	39	11.24	4.18	2.98	4.17	3.00	-0.13	2.04	-45.01	2.03	-45.00	0.69
		99	10.73	2.21	-1.76	2.01	-1.56	-0.86	-5.52	-45.14	-5.54	-45.13	-0.69
		121	6.65	0.34	-9.02	-4.90	-3.78	4.64	24.49	-3.57	-3.52	24.44	1.21
		115	5.97	-0.72	-4.45	-4.25	-0.92	0.84	24.49	1.25	1.29	24.45	-0.96
119	29	39	12.59	3.95	2.68	3.93	2.70	-0.12	2.37	-50.65	2.34	-50.62	1.16
		99	12.31	1.98	-2.65	1.68	-2.35	-1.14	-5.81	-51.29	-5.83	-51.27	-0.97
		121	7.04	-0.07	-9.18	-4.93	-4.31	4.54	25.68	-4.09	-4.00	25.59	1.69
		115	6.20	-1.23	-4.51	-4.39	-1.35	0.61	25.66	1.15	1.20	25.61	-1.08
119	61	39	12.52	4.03	2.87	4.03	2.87	-0.03	2.19	-50.34	2.17	-50.33	0.92
		99	12.11	2.04	-2.44	1.78	-2.18	-1.06	-5.97	-50.65	-6.00	-50.62	-1.15
		121	7.16	0.10	-9.20	-4.96	-4.14	4.63	26.35	-4.07	-3.96	26.24	1.78
		115	6.30	-1.03	-4.56	-4.42	-1.18	0.70	25.95	1.19	1.24	25.91	-1.06
120	1	108	7.05	3.00	-13.18	-5.57	-4.61	8.08	-1.55	-23.86	-1.79	-23.62	2.31
		113	9.13	1.63	-7.97	-5.74	-0.60	4.05	0.85	-34.69	0.82	-34.66	-1.05
		30	10.55	11.63	6.93	7.29	11.27	-1.24	38.04	1.94	1.96	38.02	0.84
		14	12.19	-0.17	-20.23	-0.26	-20.14	1.37	32.32	-3.24	-3.10	32.18	-2.24
120	2	108	4.97	2.23	-9.42	-3.93	-3.26	5.82	-1.26	-16.92	-1.39	-16.78	1.44
		113	6.28	1.36	-5.60	-4.14	-0.11	2.84	0.75	-23.33	0.71	-23.30	-0.91
		30	7.40	8.46	5.04	5.21	8.29	-0.75	26.49	1.55	1.58	26.47	0.75
		14	8.69	-0.16	-14.39	-0.22	-14.33	0.92	22.99	-2.45	-2.37	22.92	-1.40
120	34	108	4.71	2.01	-10.57	-4.37	-4.19	6.29	-0.85	-13.23	-1.36	-12.73	2.46
		113	6.05	1.27	-6.52	-4.87	-0.38	3.19	0.64	-22.34	0.64	-22.33	-0.20
		30	7.54	8.76	6.20	6.30	8.66	-0.50	27.01	1.46	1.46	27.00	-0.35
		14	10.58	0.37	-16.37	0.29	-16.29	1.15	28.75	-2.95	-2.74	28.53	-2.62
120	66	108	5.00	2.28	-10.24	-4.17	-3.80	6.26	-1.11	-15.72	-1.37	-15.47	1.93
		113	6.23	1.60	-6.25	-4.66	8.49e-03	3.15	0.65	-22.76	0.63	-22.74	-0.68
		30	7.53	9.14	5.87	5.96	9.05	-0.53	26.60	1.58	1.58	26.59	0.35
		14	9.77	0.02	-15.97	-0.06	-15.90	1.12	25.93	-2.75	-2.61	25.79	-2.00
121	1	78	3.42	1.66	-3.44	-2.19	0.42	2.19	-0.38	-11.56	-1.86	-10.08	-3.79
		136	1.81	0.55	-1.88	-0.83	-0.51	-1.21	3.35	-4.08	2.57	-3.31	-2.27
		113	5.58	5.46	-4.38	-3.54	4.62	2.74	18.54	2.92	3.19	18.27	2.02
		108	4.88	2.07	-4.00	2.05	-3.99	0.29	14.33	-3.55	-2.68	13.46	3.85
121	2	78	2.39	1.18	-2.44	-1.56	0.29	1.55	-0.29	-8.08	-1.16	-7.20	-2.46
		136	1.15	0.40	-1.33	-0.58	-0.36	-0.86	2.17	-2.41	1.64	-1.88	-1.47
		113	3.65	3.79	-3.10	-2.52	3.22	1.90	11.85	1.93	2.10	11.68	1.28
		108	3.40	1.49	-2.75	1.47	-2.74	0.25	10.09	-2.29	-1.76	9.56	2.51
121	22	78	1.55	0.96	-2.50	-1.77	0.23	1.41	-0.29	-4.60	-1.12	-3.77	-1.70
		136	0.86	0.50	-1.79	-0.82	-0.47	-1.13	1.76	-1.32	1.57	-1.13	-0.74
		113	3.60	3.90	-2.86	-2.34	3.38	1.79	11.88	2.05	2.07	11.87	0.37
		108	4.39	1.91	-2.98	1.91	-2.98	0.18	13.87	-1.93	-1.77	13.71	1.58
121	54	78	2.08	1.13	-2.54	-1.69	0.28	1.55	-0.31	-6.75	-1.11	-5.96	-2.12
		136	1.01	0.42	-1.59	-0.74	-0.42	-0.99	1.97	-1.82	1.58	-1.42	-1.16
		113	3.62	4.00	-3.11	-2.55	3.43	1.93	11.66	1.99	2.08	11.58	0.89
		108	3.87	1.72	-2.95	1.70	-2.93	0.32	11.84	-2.08	-1.76	11.52	2.10

122	1	107	7.05	3.00	-13.18	-5.57	-4.61	8.08	23.86	1.55	1.79	23.62	-2.31
		112	9.13	1.63	-7.97	-5.74	-0.60	4.05	34.69	-0.85	-0.82	34.66	1.05
		29	10.55	11.63	6.93	7.29	11.27	-1.24	-1.94	-38.04	-1.96	-38.02	-0.84
		13	12.19	-0.17	-20.23	-0.26	-20.14	1.37	3.24	-32.32	3.10	-32.18	2.24
122	2	107	4.97	2.23	-9.42	-3.93	-3.26	5.82	16.92	1.26	1.39	16.78	-1.44
		112	6.28	1.36	-5.60	-4.14	-0.11	2.84	23.33	-0.75	-0.71	23.30	0.91
		29	7.40	8.46	5.04	5.21	8.29	-0.75	-1.55	-26.49	-1.58	-26.47	-0.75
		13	8.69	-0.16	-14.39	-0.22	-14.33	0.92	2.45	-22.99	2.37	-22.92	1.40
122	28	107	4.71	2.01	-10.57	-4.37	-4.19	6.29	13.23	0.85	1.36	12.73	-2.46
		112	6.05	1.27	-6.52	-4.87	-0.38	3.19	22.34	-0.64	-0.64	22.33	0.20
		29	7.54	8.76	6.20	6.30	8.66	-0.50	-1.46	-27.01	-1.46	-27.00	0.35
		13	10.58	0.37	-16.37	0.29	-16.29	1.15	2.95	-28.75	2.74	-28.53	2.62
122	60	107	5.00	2.28	-10.24	-4.17	-3.80	6.26	15.72	1.11	1.37	15.47	-1.93
		112	6.23	1.60	-6.25	-4.66	8.49e-03	3.15	22.76	-0.65	-0.63	22.74	0.68
		29	7.53	9.14	5.87	5.96	9.05	-0.53	-1.58	-26.60	-1.58	-26.59	-0.35
		13	9.77	0.02	-15.97	-0.06	-15.90	1.12	2.75	-25.93	2.61	-25.79	2.00
123	1	79	3.42	1.66	-3.44	-2.19	0.42	2.19	11.56	0.38	1.86	10.08	3.79
		137	1.81	0.55	-1.88	-0.83	-0.51	-1.21	4.08	-3.35	-2.57	3.31	2.27
		112	5.58	5.46	-4.38	-3.54	4.62	2.74	-2.92	-18.54	-3.19	-18.27	-2.02
		107	4.88	2.07	-4.00	2.05	-3.99	0.29	3.55	-14.33	2.68	-13.46	-3.85
123	2	79	2.39	1.18	-2.44	-1.56	0.29	1.55	8.08	0.29	1.16	7.20	2.46
		137	1.15	0.40	-1.33	-0.58	-0.36	-0.86	2.41	-2.17	-1.64	1.88	1.47
		112	3.65	3.79	-3.10	-2.52	3.22	1.90	-1.93	-11.85	-2.10	-11.68	-1.28
		107	3.40	1.49	-2.75	1.47	-2.74	0.25	2.29	-10.09	1.76	-9.56	-2.51
123	24	79	1.55	0.96	-2.50	-1.77	0.23	1.41	4.60	0.29	1.12	3.77	1.70
		137	0.86	0.50	-1.79	-0.82	-0.47	-1.13	1.32	-1.76	-1.57	1.13	0.74
		112	3.60	3.90	-2.86	-2.34	3.38	1.79	-2.05	-11.88	-2.07	-11.87	-0.37
		107	4.39	1.91	-2.98	1.91	-2.98	0.18	1.93	-13.87	1.77	-13.71	-1.58
123	56	79	2.08	1.13	-2.54	-1.69	0.28	1.55	6.75	0.31	1.11	5.96	2.12
		137	1.01	0.42	-1.59	-0.74	-0.42	-0.99	1.82	-1.97	-1.58	1.42	1.16
		112	3.62	4.00	-3.11	-2.55	3.43	1.93	-1.99	-11.66	-2.08	-11.58	-0.89
		107	3.87	1.72	-2.95	1.70	-2.93	0.32	2.08	-11.84	1.76	-11.52	-2.10
124	1	117	2.45	-0.13	-2.49	-0.23	-2.39	0.48	8.05	-0.36	0.72	6.96	-2.82
		114	3.60	4.28	-3.27	-2.38	3.40	-2.43	11.12	1.03	1.04	11.11	-0.31
		138	1.15	0.62	-1.71	-0.26	-0.83	1.13	1.39	-2.98	1.38	-2.97	0.21
		140	2.06	1.98	-1.48	-0.72	1.22	-1.43	1.65	-5.14	-0.27	-3.22	3.06
124	2	117	1.63	-0.09	-1.75	-0.15	-1.69	0.30	5.34	-0.13	0.51	4.69	-1.76
		114	2.36	2.92	-2.28	-1.69	2.33	-1.65	7.10	0.64	0.65	7.09	-0.20
		138	0.74	0.44	-1.16	-0.14	-0.58	0.77	0.89	-1.85	0.88	-1.84	0.13
		140	1.35	1.35	-0.98	-0.49	0.85	-0.95	0.98	-3.40	-0.19	-2.23	1.94
124	8	117	1.98	-0.14	-1.89	-0.14	-1.89	-7.81e-03	6.87	-0.03	0.54	6.30	-1.89
		114	2.86	3.12	-2.58	-1.78	2.32	-1.98	9.01	0.63	0.64	8.99	-0.38
		138	0.37	0.08	-0.99	-0.23	-0.69	0.48	1.01	0.11	0.87	0.25	0.32
		140	1.36	1.52	-1.34	-0.62	0.80	-1.25	1.63	-2.60	-0.21	-0.76	2.10
124	40	117	1.78	-0.14	-1.86	-0.15	-1.85	0.17	5.98	-0.06	0.53	5.40	-1.79
		114	2.57	3.04	-2.47	-1.79	2.37	-1.81	7.82	0.62	0.63	7.81	-0.28
		138	0.57	0.31	-1.09	-0.14	-0.64	0.66	0.89	-0.96	0.87	-0.94	0.21
		140	1.34	1.43	-1.11	-0.53	0.84	-1.07	1.18	-3.05	-0.21	-1.66	1.98
125	1	86	8.73	2.53	-2.08	2.52	-2.07	-0.27	35.45	3.78	3.92	35.30	2.11
		36	9.50	5.54	1.01	4.55	2.01	1.88	38.00	-1.95	-1.95	37.99	0.28
		114	6.69	-0.90	-5.69	-4.27	-2.32	-2.19	-1.55	-27.88	-1.56	-27.87	-0.49
		117	6.40	-0.76	-9.98	-5.72	-5.03	-4.60	2.19	-22.18	2.11	-22.09	-1.45
125	2	86	6.14	1.76	-1.35	1.76	-1.35	-0.05	25.08	2.70	2.78	25.01	1.27
		36	6.61	3.84	1.02	3.20	1.66	1.18	26.70	-1.28	-1.28	26.70	0.19
		114	4.51	-0.61	-3.87	-3.07	-1.41	-1.40	-1.02	-18.99	-1.02	-18.98	-0.34
		117	4.44	-0.35	-7.16	-4.08	-3.44	-3.39	1.53	-15.47	1.50	-15.44	-0.79

125	12	86	6.92	1.58	-2.12	1.52	-2.07	-0.44	27.74	2.63	2.68	27.69	1.12
		36	7.34	3.33	1.17	3.10	1.40	0.67	29.53	-1.44	-1.44	29.53	0.05
		114	4.03	-0.77	-4.57	-3.36	-1.97	-1.77	-1.06	-16.51	-1.06	-16.51	-0.15
		117	4.27	-0.18	-8.47	-4.35	-4.30	-4.14	1.52	-13.70	1.49	-13.67	-0.66
125	50	86	6.55	2.01	-1.40	2.01	-1.40	0.06	26.64	2.72	2.79	26.57	1.27
		36	6.97	4.23	1.43	3.58	2.07	1.18	28.06	-1.33	-1.33	28.06	0.14
		114	4.31	-0.73	-4.09	-3.52	-1.30	-1.26	-1.04	-17.99	-1.05	-17.98	-0.32
		117	4.33	-0.41	-7.73	-4.50	-3.63	-3.63	1.53	-14.82	1.50	-14.79	-0.78
126	1	114	3.60	4.28	-3.27	-2.38	3.40	2.43	11.12	1.03	1.04	11.11	0.31
		120	2.45	-0.13	-2.49	-0.23	-2.39	-0.48	8.05	-0.36	0.72	6.96	2.82
		139	2.06	1.98	-1.48	-0.72	1.22	1.43	1.65	-5.14	-0.27	-3.22	-3.06
		138	1.15	0.62	-1.71	-0.26	-0.83	-1.13	1.39	-2.98	1.38	-2.97	-0.21
126	2	114	2.36	2.92	-2.28	-1.69	2.33	1.65	7.10	0.64	0.65	7.09	0.20
		120	1.63	-0.09	-1.75	-0.15	-1.69	-0.30	5.34	-0.13	0.51	4.69	1.76
		139	1.35	1.35	-0.98	-0.49	0.85	0.95	0.98	-3.40	-0.19	-2.23	-1.94
		138	0.74	0.44	-1.16	-0.14	-0.58	-0.77	0.89	-1.85	0.88	-1.84	-0.13
126	8	114	2.84	3.25	-1.97	-1.38	2.65	1.66	9.00	0.64	0.65	8.99	0.28
		120	2.05	0.31	-1.62	0.26	-1.56	-0.32	7.10	0.06	0.54	6.62	1.79
		139	1.20	1.50	-1.15	-0.77	1.13	0.92	1.65	-2.30	-0.21	-0.44	-1.97
		138	0.38	0.44	-1.18	-0.38	-0.36	-0.81	0.92	0.19	0.87	0.25	-0.19
126	40	114	2.56	3.10	-2.22	-1.62	2.50	1.67	7.82	0.63	0.64	7.81	0.24
		120	1.81	0.07	-1.76	0.01	-1.71	-0.30	6.08	-0.02	0.53	5.53	1.74
		139	1.28	1.41	-1.03	-0.59	0.98	0.93	1.17	-2.91	-0.21	-1.53	-1.93
		138	0.55	0.45	-1.16	-0.21	-0.50	-0.79	0.88	-0.95	0.87	-0.94	-0.16
127	1	36	9.50	5.54	1.01	4.55	2.01	-1.88	38.00	-1.95	-1.95	37.99	-0.28
		94	8.73	2.53	-2.08	2.52	-2.07	0.27	35.45	3.78	3.92	35.30	-2.11
		120	6.40	-0.76	-9.98	-5.72	-5.03	4.60	2.19	-22.18	2.11	-22.09	1.45
		114	6.69	-0.90	-5.69	-4.27	-2.32	2.19	-1.55	-27.88	-1.56	-27.87	0.49
127	2	36	6.61	3.84	1.02	3.20	1.66	-1.18	26.70	-1.28	-1.28	26.70	-0.19
		94	6.14	1.76	-1.35	1.76	-1.35	0.05	25.08	2.70	2.78	25.01	-1.27
		120	4.44	-0.35	-7.16	-4.08	-3.44	3.39	1.53	-15.47	1.50	-15.44	0.79
		114	4.51	-0.61	-3.87	-3.07	-1.41	1.40	-1.02	-18.99	-1.02	-18.98	0.34
127	17	36	7.33	3.49	1.20	3.20	1.49	-0.76	29.53	-1.43	-1.43	29.53	-0.08
		94	6.95	1.66	-2.01	1.63	-1.98	0.35	27.89	2.64	2.69	27.83	-1.17
		120	4.21	-0.26	-8.36	-4.41	-4.22	4.05	1.52	-13.56	1.48	-13.53	0.68
		114	4.01	-0.81	-4.50	-3.42	-1.88	1.68	-1.06	-16.52	-1.06	-16.51	0.22
127	49	36	6.95	3.80	1.38	3.33	1.85	-0.95	28.06	-1.34	-1.34	28.06	-0.15
		94	6.57	1.77	-1.63	1.76	-1.62	0.16	26.61	2.71	2.78	26.54	-1.26
		120	4.41	-0.24	-7.97	-4.36	-3.86	3.86	1.53	-14.85	1.50	-14.82	0.75
		114	4.28	-0.70	-4.20	-3.38	-1.52	1.49	-1.05	-17.99	-1.05	-17.98	0.29
128	1	108	3.51	3.32	-5.46	1.63	-3.77	3.46	6.97	-4.99	-4.91	6.90	0.94
		117	1.92	0.96	-0.91	0.26	-0.21	-0.91	6.75	-1.12	-0.25	5.88	-2.47
		140	1.66	-0.04	-1.27	-1.07	-0.24	0.46	3.20	-4.52	1.95	-3.28	2.84
		78	2.40	1.88	-4.90	-2.76	-0.26	-3.15	-4.28	-7.07	-6.60	-4.75	-1.04
128	2	108	2.45	2.41	-3.82	1.18	-2.59	2.47	4.96	-3.30	-3.25	4.91	0.65
		117	1.26	0.62	-0.61	0.22	-0.21	-0.58	4.60	-0.66	-0.15	4.09	-1.54
		140	1.12	-0.01	-0.88	-0.74	-0.15	0.32	2.15	-3.09	1.43	-2.36	1.81
		78	1.66	1.32	-3.45	-1.95	-0.18	-2.22	-3.00	-4.83	-4.47	-3.37	-0.73
128	6	108	3.36	3.36	-3.87	2.09	-2.60	2.75	8.95	-3.77	-3.38	8.57	2.18
		117	1.66	1.25	-0.27	1.10	-0.12	-0.45	6.08	-0.33	-0.33	6.08	0.03
		140	0.71	0.18	-1.36	-1.22	0.04	0.45	1.69	-0.79	1.54	-0.63	0.60
		78	2.25	1.28	-3.73	-2.49	0.04	-2.16	1.07	-5.16	-4.46	0.36	-1.97
128	38	108	2.84	2.89	-4.00	1.59	-2.71	2.69	6.60	-3.46	-3.29	6.43	1.31
		117	1.35	0.85	-0.48	0.61	-0.23	-0.51	5.13	-0.37	-0.23	4.99	-0.86
		140	0.91	0.07	-1.09	-0.94	-0.08	0.39	1.95	-2.17	1.50	-1.72	1.29
		78	1.87	1.32	-3.60	-2.22	-0.07	-2.22	-1.27	-4.99	-4.50	-1.77	-1.27

129	1	14	14.90	-0.62	-30.63	-0.65	-30.59	-1.07	32.09	-8.93	-8.86	32.02	-1.78
		86	7.66	4.97	0.15	1.74	3.38	2.26	33.19	7.81	8.26	32.74	-3.35
		117	8.13	0.88	-17.09	-5.18	-11.03	-8.50	12.58	-20.15	12.11	-19.67	3.92
		108	4.69	-0.11	-7.89	-5.24	-2.76	-3.69	-10.73	-19.90	-11.13	-19.50	1.87
129	2	14	10.63	-0.45	-21.75	-0.48	-21.73	-0.69	22.85	-6.56	-6.51	22.80	-1.22
		86	5.49	3.53	0.26	1.22	2.57	1.48	23.63	5.46	5.83	23.26	-2.57
		117	5.69	0.52	-11.93	-3.73	-7.68	-5.90	8.95	-14.26	8.56	-13.87	2.98
		108	3.35	-7.44e-03	-5.65	-3.74	-1.91	-2.67	-7.84	-14.16	-8.12	-13.89	1.29
129	6	14	9.80	-1.57	-22.88	-1.64	-22.81	-1.21	19.19	-7.10	-6.63	18.71	-3.51
		86	5.58	3.76	-0.06	0.18	3.52	0.93	23.09	4.71	6.22	21.58	-5.04
		117	6.28	1.57	-12.09	-3.13	-7.39	-6.49	9.41	-17.31	8.59	-16.49	4.61
		108	4.46	1.04	-5.32	-3.01	-1.27	-3.06	-7.73	-19.96	-8.42	-19.27	2.81
129	38	14	10.62	-0.95	-23.27	-0.99	-23.22	-0.99	21.77	-6.87	-6.72	21.61	-2.09
		86	5.60	3.58	0.35	0.83	3.11	1.14	23.65	5.39	6.13	22.91	-3.60
		117	6.03	0.90	-12.32	-3.63	-7.80	-6.28	9.25	-15.71	8.69	-15.15	3.70
		108	3.74	0.39	-5.58	-3.50	-1.69	-2.84	-7.91	-16.79	-8.32	-16.38	1.87
130	1	136	2.54	-1.46	-2.58	-2.48	-1.56	-0.33	10.54	4.48	5.62	9.39	2.37
		77	2.96	3.77	0.75	2.41	2.11	1.51	-7.71	-12.31	-8.01	-12.02	1.13
		133	1.48	1.40	-0.11	0.18	1.11	-0.60	4.04	-2.67	-2.23	3.60	1.65
		142	1.16	3.74e-03	-1.20	2.10e-03	-1.20	0.04	2.75	-2.23	1.76	-1.25	-1.98
130	2	136	1.78	-1.01	-1.85	-1.79	-1.08	-0.23	7.37	3.26	4.13	6.50	1.68
		77	2.11	2.68	0.52	1.73	1.47	1.07	-5.69	-8.71	-5.87	-8.53	0.72
		133	1.04	1.02	-0.09	0.13	0.80	-0.44	2.80	-1.90	-1.61	2.51	1.13
		142	0.83	4.62e-03	-0.84	1.90e-03	-0.84	0.05	1.93	-1.65	1.22	-0.94	-1.43
130	6	136	1.31	-0.98	-2.07	-2.07	-0.98	0.02	5.45	1.96	2.05	5.37	0.54
		77	2.62	2.83	0.48	1.83	1.48	1.16	-6.39	-11.81	-9.38	-8.82	2.69
		133	1.78	1.13	-0.26	-5.14e-03	0.88	-0.53	4.16	-3.98	-2.16	2.35	3.39
		142	1.31	-0.03	-0.92	-0.16	-0.79	0.32	2.33	-3.69	0.76	-2.12	-2.64
130	54	136	1.72	-1.05	-2.09	-2.07	-1.07	-0.16	7.04	3.34	4.10	6.28	1.49
		77	2.34	2.92	0.46	1.83	1.55	1.22	-6.71	-9.78	-7.33	-9.16	1.23
		133	1.09	1.17	-0.11	0.10	0.96	-0.48	2.70	-2.38	-1.69	2.01	1.74
		142	0.98	-0.02	-0.92	-0.05	-0.89	0.17	2.25	-2.22	1.23	-1.21	-1.88
131	1	142	0.71	0.15	-1.09	-0.06	-0.88	-0.47	2.28	-0.12	1.31	0.85	-1.18
		133	0.89	0.76	-0.16	-0.11	0.71	0.22	1.33	-2.25	-1.39	0.47	1.53
		134	0.31	-0.21	-0.31	-0.25	-0.26	-0.05	1.26	0.23	1.26	0.24	-0.07
		74	0.17	0.03	-0.27	0.02	-0.27	0.04	0.61	0.20	0.28	0.54	0.16
131	2	142	0.51	0.10	-0.76	-0.04	-0.61	-0.32	1.58	-0.17	0.88	0.53	-0.86
		133	0.62	0.55	-0.12	-0.08	0.52	0.14	0.93	-1.58	-0.99	0.34	1.06
		134	0.21	-0.11	-0.17	-0.15	-0.14	-0.03	0.85	0.16	0.84	0.16	-0.07
		74	0.13	0.03	-0.20	0.03	-0.19	0.02	0.44	0.09	0.16	0.37	0.14
131	9	142	0.50	-0.10	-0.67	-0.15	-0.62	-0.15	1.73	-0.38	0.17	1.19	-0.93
		133	1.09	0.56	-0.26	-0.19	0.50	0.22	1.56	-3.06	-1.73	0.22	2.10
		134	0.50	-0.10	-0.29	-0.29	-0.11	0.03	1.80	-0.28	1.52	-1.14e-03	0.71
		74	0.28	-6.34e-03	-0.29	-0.09	-0.21	0.13	1.09	0.81	0.82	1.08	-0.05
131	41	142	0.48	-3.00e-03	-0.74	-0.09	-0.65	-0.24	1.61	-0.26	0.57	0.79	-0.93
		133	0.83	0.60	-0.17	-0.14	0.57	0.16	1.22	-2.22	-1.33	0.33	1.51
		134	0.31	-0.04	-0.19	-0.19	-0.04	-1.91e-03	1.17	0.05	1.11	0.10	0.24
		74	0.18	0.02	-0.26	2.83e-03	-0.24	0.07	0.70	0.39	0.42	0.68	0.08
132	1	74	0.17	0.03	-0.27	0.02	-0.27	-0.04	0.61	0.20	0.28	0.54	-0.16
		134	0.31	-0.21	-0.31	-0.25	-0.26	0.05	1.26	0.23	1.26	0.24	0.07
		135	0.89	0.76	-0.16	-0.11	0.71	-0.22	1.33	-2.25	-1.39	0.47	-1.53
		141	0.71	0.15	-1.09	-0.06	-0.88	0.47	2.28	-0.12	1.31	0.85	1.18
132	2	74	0.13	0.03	-0.20	0.03	-0.19	-0.02	0.44	0.09	0.16	0.37	-0.14
		134	0.21	-0.11	-0.17	-0.15	-0.14	0.03	0.85	0.16	0.84	0.16	0.07
		135	0.62	0.55	-0.12	-0.08	0.52	-0.14	0.93	-1.58	-0.99	0.34	-1.06
		141	0.51	0.10	-0.76	-0.04	-0.61	0.32	1.58	-0.17	0.88	0.53	0.86

132	3	74	0.28	-6.34e-03	-0.29	-0.09	-0.21	-0.13	1.09	0.81	0.82	1.08	0.05
		134	0.50	-0.10	-0.29	-0.29	-0.11	-0.03	1.80	-0.28	1.52	-1.14e-03	-0.71
		135	1.09	0.56	-0.26	-0.19	0.50	-0.22	1.56	-3.06	-1.73	0.22	-2.10
		141	0.50	-0.10	-0.67	-0.15	-0.62	0.15	1.73	-0.38	0.17	1.19	0.93
132	35	74	0.18	0.02	-0.26	2.83e-03	-0.24	-0.07	0.70	0.39	0.42	0.68	-0.08
		134	0.31	-0.04	-0.19	-0.19	-0.04	1.91e-03	1.17	0.05	1.11	0.10	-0.24
		135	0.83	0.60	-0.17	-0.14	0.57	-0.16	1.22	-2.22	-1.33	0.33	-1.51
		141	0.48	-3.00e-03	-0.74	-0.09	-0.65	0.24	1.61	-0.26	0.57	0.79	0.93
133	1	139	1.62	1.09	0.02	0.15	0.96	-0.35	4.51	-2.70	-2.34	4.15	1.58
		141	1.21	-0.13	-1.13	-0.14	-1.12	-0.11	3.07	-2.06	2.16	-1.15	-1.96
		137	2.79	-1.38	-2.18	-1.99	-1.57	-0.34	10.43	-1.04	-0.63	10.02	2.13
		79	3.17	3.12	0.63	1.62	2.12	1.22	-1.20	-12.71	-1.35	-12.56	1.31
133	2	139	1.15	0.78	7.84e-03	0.10	0.68	-0.26	3.19	-1.92	-1.69	2.95	1.07
		141	0.87	-0.10	-0.78	-0.11	-0.77	-0.07	2.16	-1.54	1.52	-0.89	-1.41
		137	1.96	-0.97	-1.54	-1.41	-1.09	-0.23	7.30	-0.82	-0.54	7.02	1.49
		79	2.27	2.19	0.44	1.14	1.50	0.86	-0.80	-9.10	-0.89	-9.01	0.87
133	28	139	1.58	1.48	0.20	0.21	1.48	-0.09	-2.17	-6.24	-2.45	-5.96	1.04
		141	1.42	-0.02	-0.91	-0.05	-0.88	0.16	3.58	-3.03	0.91	-0.36	-3.24
		137	2.41	-1.13	-1.48	-1.43	-1.18	-0.13	8.08	-2.84	-2.65	7.90	1.40
		79	4.59	2.79	0.80	1.31	2.29	0.87	-2.05	-18.84	-2.40	-18.49	2.41
133	60	139	0.70	1.09	0.11	0.15	1.05	-0.20	-0.11	-2.65	-2.06	-0.70	1.08
		141	1.07	-0.10	-0.85	-0.11	-0.85	0.02	2.74	-2.16	1.30	-0.72	-2.23
		137	2.19	-1.07	-1.59	-1.51	-1.15	-0.18	7.78	-1.86	-1.63	7.55	1.48
		79	3.31	2.49	0.60	1.23	1.86	0.89	-1.18	-13.42	-1.38	-13.23	1.52
134	1	78	3.17	3.12	0.63	1.62	2.12	-1.22	-1.20	-12.71	-1.35	-12.56	-1.31
		136	2.79	-1.38	-2.18	-1.99	-1.57	0.34	10.43	-1.04	-0.63	10.02	-2.13
		142	1.21	-0.13	-1.13	-0.14	-1.12	0.11	3.07	-2.06	2.16	-1.15	1.96
		140	1.62	1.09	0.02	0.15	0.96	0.35	4.51	-2.70	-2.34	4.15	-1.58
134	2	78	2.27	2.19	0.44	1.14	1.50	-0.86	-0.80	-9.10	-0.89	-9.01	-0.87
		136	1.96	-0.97	-1.54	-1.41	-1.09	0.23	7.30	-0.82	-0.54	7.02	-1.49
		142	0.87	-0.10	-0.78	-0.11	-0.77	0.07	2.16	-1.54	1.52	-0.89	1.41
		140	1.15	0.78	7.84e-03	0.10	0.68	0.26	3.19	-1.92	-1.69	2.95	-1.07
134	22	78	0.67	1.88	-0.02	1.04	0.82	-0.94	1.36	-0.66	1.12	-0.42	0.65
		136	1.81	-0.93	-1.83	-1.70	-1.07	0.32	7.14	0.41	0.86	6.69	-1.68
		142	0.89	-0.10	-0.91	-0.25	-0.77	0.31	2.27	-1.59	2.25	-1.57	-0.24
		140	3.11	0.46	-0.44	5.42e-03	0.01	0.45	12.21	-1.21	-1.11	12.11	-1.17
134	48	78	2.69	2.43	0.55	1.25	1.72	-0.91	-1.66	-11.11	-1.89	-10.89	-1.44
		136	2.29	-1.04	-1.63	-1.49	-1.18	0.25	7.93	-2.24	-2.14	7.83	-1.00
		142	1.10	-0.04	-0.89	-0.05	-0.88	0.07	2.78	-2.15	1.06	-0.43	2.35
		140	1.06	0.98	0.14	0.20	0.91	0.23	2.07	-2.72	-2.30	1.65	-1.35
135	1	140	0.85	0.74	-0.13	-0.07	0.69	-0.21	1.31	-2.15	-1.30	0.46	-1.49
		142	0.72	0.10	-1.17	-0.15	-0.92	0.50	2.37	0.03	1.52	0.88	1.12
		74	0.16	0.08	-0.28	0.07	-0.27	-0.06	0.59	0.17	0.26	0.50	-0.17
		138	0.38	-0.22	-0.42	-0.32	-0.32	0.10	1.52	0.20	1.51	0.20	0.08
135	2	140	0.60	0.53	-0.09	-0.06	0.50	-0.15	0.91	-1.50	-0.93	0.33	-1.03
		142	0.51	0.07	-0.81	-0.10	-0.64	0.35	1.65	-0.05	1.04	0.55	0.82
		74	0.12	0.07	-0.20	0.06	-0.19	-0.04	0.42	0.06	0.14	0.34	-0.15
		138	0.26	-0.14	-0.27	-0.21	-0.19	0.06	1.04	0.13	1.03	0.13	0.08
135	22	140	1.11	0.27	-0.17	-0.17	0.26	-0.04	0.55	-4.17	-0.30	-3.32	-1.81
		142	0.57	0.09	-1.02	-0.23	-0.70	0.50	1.90	1.65	1.74	1.80	-0.12
		74	0.42	0.15	-0.34	0.05	-0.24	0.20	1.80	0.25	0.42	1.63	0.48
		138	1.22	-0.06	-0.64	-0.26	-0.44	0.28	1.57	-3.76	1.38	-3.57	0.99
135	66	140	0.88	0.72	-0.07	-0.02	0.67	-0.19	2.09	-1.42	-1.25	1.92	-0.75
		142	0.69	0.04	-0.82	-0.09	-0.69	0.31	1.73	-0.94	0.79	-3.18e-03	1.28
		74	0.26	0.17	-0.27	0.12	-0.23	-0.14	0.37	-0.56	-0.03	-0.17	-0.46
		138	0.37	-0.03	-0.19	-0.19	-0.03	-0.02	1.76	0.85	0.93	1.67	-0.27

136	1	138	0.38	-0.22	-0.42	-0.32	-0.32	-0.10	1.52	0.20	1.51	0.20	-0.08
		74	0.16	0.08	-0.28	0.07	-0.27	0.06	0.59	0.17	0.26	0.50	0.17
		141	0.72	0.10	-1.17	-0.15	-0.92	-0.50	2.37	0.03	1.52	0.88	-1.12
		139	0.85	0.74	-0.13	-0.07	0.69	0.21	1.31	-2.15	-1.30	0.46	1.49
136	2	138	0.26	-0.14	-0.27	-0.21	-0.19	-0.06	1.04	0.13	1.03	0.13	-0.08
		74	0.12	0.07	-0.20	0.06	-0.19	0.04	0.42	0.06	0.14	0.34	0.15
		141	0.51	0.07	-0.81	-0.10	-0.64	-0.35	1.65	-0.05	1.04	0.55	-0.82
		139	0.60	0.53	-0.09	-0.06	0.50	0.15	0.91	-1.50	-0.93	0.33	1.03
136	28	138	0.96	0.19	-0.21	-0.16	0.13	0.14	4.02	0.56	0.75	3.83	0.79
		74	0.51	0.30	-0.37	0.15	-0.22	0.27	0.36	-1.48	-0.21	-0.92	0.85
		141	0.93	0.04	-0.76	-0.03	-0.68	-0.23	1.77	-2.11	0.40	-0.75	-1.85
		139	1.40	0.91	-0.04	0.04	0.84	0.26	4.09	-1.66	-1.64	4.08	0.31
136	60	138	0.37	-0.03	-0.19	-0.19	-0.03	0.02	1.76	0.85	0.93	1.67	0.27
		74	0.26	0.17	-0.27	0.12	-0.23	0.14	0.37	-0.56	-0.03	-0.17	0.46
		141	0.69	0.04	-0.82	-0.09	-0.69	-0.31	1.73	-0.94	0.79	-3.18e-03	-1.28
		139	0.88	0.72	-0.07	-0.02	0.67	0.19	2.09	-1.42	-1.25	1.92	0.75
137	1	44	0.59	0.31	-0.30	-7.10e-03	0.01	-0.30	-25.25	-68.40	-57.16	-36.49	-18.94
		3	0.35	0.17	-0.15	0.06	-0.04	-0.15	-26.00	-40.62	-32.71	-33.91	-7.29
		143	0.20	0.23	-0.03	0.21	-0.01	-0.06	-2.82	-21.59	-19.31	-5.10	-6.12
		152	0.35	0.39	-0.05	0.39	-0.04	0.04	1.25	-33.98	-32.31	-0.43	-7.50
137	2	44	0.43	0.22	-0.21	-4.87e-03	9.73e-03	-0.22	-17.18	-49.34	-40.69	-25.83	-14.26
		3	0.25	0.12	-0.11	0.04	-0.03	-0.11	-17.67	-29.49	-23.19	-23.97	-5.90
		143	0.14	0.16	-0.02	0.15	-0.01	-0.04	-1.95	-15.41	-13.62	-3.74	-4.57
		152	0.25	0.28	-0.03	0.28	-0.03	0.03	0.95	-24.33	-23.03	-0.36	-5.59
137	19	44	0.52	0.47	-0.29	0.08	0.10	-0.38	19.38	-40.92	-40.58	19.04	-4.52
		3	0.32	0.48	-0.12	0.16	0.19	-0.30	-5.17	-33.86	-31.56	-7.48	7.80
		143	0.33	0.21	-0.01	0.02	0.18	-0.08	30.22	-5.69	9.13	15.40	-17.68
		152	0.59	0.19	-0.04	0.13	0.01	0.10	58.35	-4.72	5.47	48.16	-23.21
137	57	44	0.55	0.10	-0.13	-0.01	-0.02	-0.12	-17.51	-63.44	-40.41	-40.54	-22.97
		3	0.36	0.03	-0.15	0.03	-0.15	4.78e-03	-5.94	-39.86	-21.79	-24.01	-16.92
		143	0.18	0.19	-0.12	0.19	-0.12	-0.01	-8.80	-21.02	-20.80	-9.02	1.64
		152	0.29	0.34	-0.06	0.34	-0.06	0.04	-20.02	-33.50	-33.27	-20.26	1.76
138	1	42	0.67	1.10	-0.27	0.69	0.13	0.63	-41.29	-80.21	-74.14	-47.36	14.12
		6	0.87	0.85	-0.62	0.42	-0.20	0.66	-26.76	-99.10	-81.16	-44.69	31.23
		145	0.55	0.98	0.05	0.97	0.06	-0.07	0.52	-53.55	-53.06	0.03	5.12
		151	0.47	0.49	-0.07	0.48	-0.07	-0.03	1.46	-45.98	-45.33	0.81	5.50
138	2	42	0.48	0.78	-0.20	0.49	0.10	0.45	-29.08	-57.31	-52.72	-33.67	10.42
		6	0.62	0.60	-0.44	0.30	-0.14	0.47	-18.74	-70.87	-57.88	-31.73	22.55
		145	0.40	0.70	0.04	0.70	0.04	-0.05	0.49	-38.25	-37.88	0.11	3.81
		151	0.34	0.35	-0.05	0.35	-0.05	-0.02	1.08	-32.80	-32.30	0.59	4.08
138	28	42	0.96	1.21	-0.27	0.74	0.20	0.69	32.79	-77.18	-53.89	9.50	44.93
		6	1.18	0.95	-0.56	0.52	-0.12	0.68	13.35	-112.74	-70.36	-29.03	59.56
		145	0.34	0.73	0.08	0.73	0.09	0.04	4.20	-29.85	-29.77	4.12	1.58
		151	0.53	0.36	-0.01	0.34	0.01	0.09	43.88	-16.26	-16.21	43.83	-1.69
138	60	42	0.61	0.99	-0.24	0.61	0.14	0.57	-1.49	-63.03	-50.42	-14.10	24.83
		6	0.83	0.77	-0.51	0.40	-0.14	0.58	-4.65	-86.53	-62.20	-28.98	37.42
		145	0.36	0.75	0.06	0.75	0.06	-0.02	2.04	-33.89	-33.63	1.77	3.09
		151	0.38	0.37	-0.03	0.37	-0.02	0.02	18.49	-24.82	-24.74	18.42	1.75
139	1	26	0.73	0.68	0.04	0.68	0.04	0.03	-20.40	-81.40	-71.31	-30.49	-22.67
		8	0.76	0.68	-0.18	0.63	-0.14	-0.19	-13.03	-84.27	-63.17	-34.13	-32.53
		146	0.59	0.27	0.04	0.27	0.05	0.02	5.89	-57.01	-53.55	2.43	-14.32
		149	0.73	0.42	-0.02	0.42	-0.02	-0.01	-0.59	-74.90	-74.87	-0.62	-1.64
139	2	26	0.53	0.49	0.03	0.49	0.03	0.02	-14.45	-59.25	-51.95	-21.76	-16.55
		8	0.55	0.48	-0.13	0.45	-0.10	-0.13	-8.36	-60.77	-44.97	-24.16	-24.05
		146	0.42	0.19	0.03	0.19	0.03	0.02	4.25	-40.77	-38.21	1.69	-10.42
		149	0.54	0.29	-0.01	0.29	-0.01	-6.94e-03	-0.35	-54.71	-54.68	-0.39	-1.36

139	9	26	0.97	0.26	-0.02	0.16	0.08	0.14	-21.34	-109.16	-105.60	-24.90	-17.31
		8	0.80	0.13	-0.07	0.12	-0.05	-0.05	-32.08	-94.62	-91.73	-34.98	-13.13
		146	0.64	0.12	-0.24	-0.20	0.08	0.11	-9.96	-69.83	-69.78	-10.00	-1.57
		149	0.90	0.09	-0.16	-0.10	0.03	0.11	-0.15	-93.04	-92.91	-0.28	-3.46
139	41	26	0.75	0.39	0.04	0.37	0.05	0.07	-17.63	-83.50	-78.14	-23.00	-18.02
		8	0.63	0.36	-0.11	0.33	-0.08	-0.10	-17.87	-71.77	-62.99	-26.65	-19.91
		146	0.48	0.11	-0.01	0.04	0.06	0.06	-2.50	-50.92	-49.97	-3.46	-6.74
		149	0.72	0.15	-5.65e-03	0.13	6.19e-03	0.04	-0.05	-74.45	-74.36	-0.15	-2.65
140	1	23	1.92	1.02	-0.33	0.75	-0.06	-0.54	-37.81	-213.42	-213.23	-38.00	-5.87
		21	1.45	0.40	0.09	0.36	0.13	0.10	-25.14	-160.40	-159.49	-26.06	-11.08
		147	1.58	0.36	-0.02	0.36	-0.02	-0.01	0.40	-162.65	-162.07	-0.18	-9.74
		148	1.94	1.28	-7.55e-03	1.28	-7.19e-03	-0.02	2.91	-195.41	-195.27	2.76	5.37
140	2	23	1.40	0.73	-0.23	0.55	-0.04	-0.38	-26.69	-155.50	-155.38	-26.82	-4.00
		21	1.06	0.28	0.07	0.26	0.09	0.06	-18.12	-117.85	-117.29	-18.68	-7.45
		147	1.16	0.27	-0.01	0.27	-0.01	-0.01	0.32	-119.53	-119.15	-0.07	-6.75
		148	1.42	0.93	-4.89e-03	0.93	-4.68e-03	-0.01	2.10	-142.54	-142.44	2.00	3.79
140	19	23	1.67	1.01	-0.19	0.85	-0.02	-0.42	-25.93	-182.38	-182.09	-26.23	-6.83
		21	1.31	0.54	0.13	0.53	0.14	0.05	-19.54	-143.38	-142.16	-20.76	-12.25
		147	1.44	0.58	0.04	0.58	0.04	-4.18e-03	-0.63	-147.93	-146.88	-1.68	-12.40
		148	1.70	1.28	0.02	1.28	0.03	-0.03	2.45	-170.61	-170.60	2.44	0.83
140	51	23	1.62	0.88	-0.21	0.71	-0.04	-0.40	-26.44	-177.67	-177.48	-26.63	-5.38
		21	1.26	0.40	0.10	0.39	0.11	0.05	-19.34	-138.02	-137.34	-20.01	-8.90
		147	1.37	0.42	6.51e-03	0.42	6.84e-03	-0.01	-0.07	-141.13	-140.56	-0.63	-8.92
		148	1.64	1.13	7.59e-03	1.13	7.94e-03	-0.02	2.32	-164.53	-164.49	2.28	2.42
141	1	28	0.27	1.62	0.13	1.52	0.23	0.37	1.23	-23.83	-0.18	-22.41	5.79
		23	1.61	1.26	-0.35	1.24	-0.33	-0.19	-29.32	-175.55	-169.20	-35.67	-29.80
		148	1.58	1.44	0.06	1.44	0.07	0.08	6.13	-155.37	-154.66	5.42	-10.69
		150	0.23	0.83	-0.03	0.83	-0.03	1.64e-03	0.79	-20.82	-15.50	-4.54	9.32
141	2	28	0.19	1.17	0.09	1.09	0.16	0.27	1.67	-16.56	0.43	-15.32	4.59
		23	1.17	0.91	-0.25	0.90	-0.23	-0.13	-20.59	-127.37	-122.95	-25.01	-21.28
		148	1.15	1.04	0.04	1.04	0.05	0.06	4.38	-113.18	-112.71	3.91	-7.43
		150	0.16	0.59	-0.02	0.59	-0.02	9.93e-04	0.59	-14.70	-10.78	-3.32	6.67
141	19	28	0.22	1.41	0.10	1.37	0.14	0.21	-4.77	-23.25	-8.60	-19.43	7.49
		23	1.39	1.17	-0.22	1.17	-0.22	-0.08	-20.55	-149.64	-146.05	-24.14	-21.21
		148	1.38	1.42	0.08	1.41	0.09	0.12	4.79	-135.85	-135.71	4.64	-4.48
		150	0.27	0.94	-0.02	0.94	-0.01	-0.07	-4.15	-26.60	-21.76	-9.00	9.24
141	51	28	0.21	1.33	0.10	1.27	0.15	0.26	0.10	-18.96	-2.56	-16.30	6.61
		23	1.35	1.07	-0.24	1.06	-0.23	-0.12	-20.19	-144.82	-140.66	-24.35	-22.40
		148	1.32	1.24	0.06	1.23	0.06	0.09	4.65	-130.54	-130.27	4.38	-6.09
		150	0.21	0.77	-0.02	0.77	-0.02	-0.03	-1.53	-20.02	-15.69	-5.86	7.83
142	1	6	1.00	1.13	-0.44	1.00	-0.31	0.43	-24.67	-113.24	-90.76	-47.14	38.54
		28	0.34	1.36	0.09	1.31	0.14	-0.24	-3.22	-33.73	-15.42	-21.53	14.94
		150	0.26	1.00	-0.03	0.99	-0.03	-0.04	-3.53	-24.85	-24.59	-3.78	-2.32
		145	0.83	0.89	0.07	0.89	0.07	-9.99e-03	9.05	-78.18	-75.09	5.97	16.11
142	2	6	0.71	0.80	-0.32	0.71	-0.23	0.30	-17.09	-80.69	-64.36	-33.42	27.79
		28	0.24	0.97	0.07	0.94	0.10	-0.17	-1.68	-24.06	-11.00	-14.74	11.03
		150	0.19	0.71	-0.02	0.71	-0.02	-0.03	-2.57	-17.72	-17.58	-2.71	-1.44
		145	0.59	0.64	0.05	0.64	0.05	-7.39e-03	6.47	-55.50	-53.27	4.24	11.53
142	28	6	0.90	1.02	-0.30	0.93	-0.20	0.34	-2.63	-94.14	-67.61	-29.16	41.52
		28	0.47	1.19	0.08	1.19	0.09	-0.05	6.47	-44.33	-18.36	-19.50	25.39
		150	0.32	1.06	-0.03	1.06	-0.03	0.08	-4.04	-31.83	-27.37	-8.50	10.21
		145	0.74	0.99	0.10	0.99	0.10	-2.95e-03	13.48	-65.74	-57.91	5.65	23.65
142	44	6	0.79	0.86	-0.32	0.77	-0.23	0.32	-18.44	-88.60	-73.78	-33.26	28.64
		28	0.37	1.07	0.08	1.04	0.12	-0.19	-2.15	-36.51	-22.98	-15.69	16.79
		150	0.28	0.78	-0.02	0.77	-0.02	-0.05	-3.46	-27.79	-27.44	-3.82	2.92
		145	0.64	0.70	0.06	0.70	0.06	-0.01	4.72	-61.67	-59.40	2.44	12.08

143	1	21	1.17	0.68	-0.05	0.68	-0.05	0.04	-21.04	-128.42	-127.13	-22.33	-11.71
		26	0.68	0.74	0.01	0.74	0.02	-0.08	-26.04	-77.32	-72.03	-31.33	-15.60
		149	0.74	0.37	-5.90e-03	0.37	-5.46e-03	0.01	1.14	-75.06	-73.16	-0.77	-11.90
		147	1.15	0.47	0.02	0.46	0.02	-0.03	1.32	-117.05	-117.05	1.32	0.37
143	2	21	0.87	0.49	-0.03	0.49	-0.03	0.02	-15.20	-94.67	-93.88	-15.99	-7.90
		26	0.49	0.53	0.01	0.53	0.02	-0.05	-18.45	-56.29	-52.38	-22.36	-11.52
		149	0.54	0.26	-4.11e-03	0.26	-3.77e-03	9.42e-03	0.78	-54.82	-53.48	-0.57	-8.54
		147	0.85	0.33	0.01	0.33	0.01	-0.02	1.07	-86.78	-86.78	1.07	0.18
143	6	21	1.16	0.49	-0.06	0.49	-0.06	3.98e-03	-16.07	-125.50	-125.06	-16.51	-6.90
		26	0.72	0.61	0.03	0.55	0.09	-0.18	-17.86	-80.33	-75.25	-22.94	-17.08
		149	0.81	0.13	-0.04	0.06	0.03	-0.08	-0.99	-84.67	-82.63	-3.03	-12.89
		147	1.20	0.13	-0.06	0.13	-0.06	-7.69e-03	0.21	-123.71	-123.71	0.21	0.06
143	38	21	1.06	0.52	-0.04	0.52	-0.04	6.94e-03	-15.94	-115.72	-115.20	-16.46	-7.20
		26	0.62	0.58	0.03	0.56	0.05	-0.10	-17.91	-69.99	-65.31	-22.58	-14.88
		149	0.69	0.18	6.17e-03	0.18	0.01	-0.03	0.02	-71.08	-69.49	-1.57	-10.52
		147	1.08	0.26	-0.02	0.26	-0.02	-0.02	0.91	-110.64	-110.64	0.91	-0.18
144	1	8	0.74	0.47	-0.35	0.27	-0.15	-0.36	-12.43	-81.23	-60.17	-33.49	-31.71
		44	0.57	0.58	-0.07	0.41	0.10	-0.28	-23.52	-66.90	-54.75	-35.68	-19.48
		152	0.35	0.19	-0.06	0.18	-0.06	0.02	0.97	-34.94	-33.44	-0.53	-7.19
		146	0.45	0.43	0.03	0.42	0.04	0.08	-0.75	-45.20	-44.06	-1.88	-7.01
144	2	8	0.54	0.34	-0.25	0.19	-0.11	-0.25	-8.09	-58.66	-43.03	-23.72	-23.37
		44	0.41	0.41	-0.05	0.29	0.07	-0.20	-15.92	-48.26	-38.94	-25.24	-14.65
		152	0.25	0.13	-0.04	0.13	-0.04	0.02	0.75	-25.02	-23.84	-0.43	-5.37
		146	0.32	0.30	0.02	0.29	0.03	0.05	-0.45	-32.46	-31.58	-1.33	-5.24
144	19	8	1.14	0.63	-0.27	0.40	-0.03	-0.39	34.59	-95.71	-47.91	-13.21	-62.80
		44	0.99	0.77	-0.05	0.52	0.19	-0.38	52.85	-64.08	-33.39	22.15	-51.45
		152	0.44	0.11	-0.07	0.03	0.01	-0.09	46.20	0.78	1.25	45.72	-4.62
		146	0.25	0.20	0.08	0.20	0.08	-1.03e-03	12.66	-16.72	-14.10	10.04	-8.36
144	51	8	0.77	0.47	-0.27	0.29	-0.08	-0.32	11.69	-72.32	-43.30	-17.33	-39.95
		44	0.61	0.58	-0.05	0.40	0.13	-0.28	16.04	-52.42	-33.05	-3.32	-30.83
		152	0.27	0.10	-0.03	0.10	-0.02	-0.03	19.38	-12.88	-11.98	18.49	-5.30
		146	0.27	0.28	0.05	0.27	0.05	0.03	4.88	-24.78	-23.11	3.21	-6.85
145	1	4	0.43	0.51	-0.36	0.10	0.05	0.43	-43.36	-45.01	-44.07	-44.30	0.81
		42	0.70	0.58	-0.71	-0.11	-0.03	0.65	-42.87	-81.35	-76.03	-48.20	13.29
		151	0.48	0.88	-0.04	0.88	-0.03	-0.05	1.89	-44.86	-44.05	1.07	6.11
		144	0.28	0.46	-0.08	0.45	-0.06	0.08	-3.79	-29.60	-28.69	-4.71	4.77
145	2	4	0.30	0.36	-0.26	0.07	0.04	0.31	-30.43	-32.38	-31.29	-31.52	0.97
		42	0.50	0.41	-0.51	-0.08	-0.02	0.46	-30.22	-58.15	-54.10	-34.28	9.84
		151	0.34	0.63	-0.03	0.63	-0.02	-0.04	1.39	-32.01	-31.38	0.77	4.51
		144	0.20	0.33	-0.05	0.32	-0.05	0.06	-2.71	-21.04	-20.34	-3.41	3.52
145	18	4	0.56	0.15	-0.17	0.14	-0.16	0.04	-22.49	-65.73	-61.25	-26.96	13.17
		42	0.83	0.18	-0.20	0.02	-0.04	0.18	-39.22	-98.72	-86.46	-51.48	24.07
		151	0.43	0.73	-0.09	0.69	-0.06	-0.16	-9.23	-45.85	-45.58	-9.50	-3.13
		144	0.34	0.33	-0.27	0.32	-0.27	-0.04	4.55	-31.65	-30.01	2.90	-7.55
145	50	4	0.38	0.25	-0.20	0.10	-0.04	0.21	-25.31	-44.88	-41.97	-28.22	6.97
		42	0.62	0.33	-0.40	-0.04	-0.03	0.37	-32.19	-72.61	-64.87	-39.93	15.90
		151	0.36	0.70	-0.05	0.69	-0.04	-0.09	-3.70	-36.46	-36.41	-3.76	1.36
		144	0.24	0.34	-0.14	0.34	-0.14	0.02	-0.84	-23.41	-23.36	-0.89	-1.10
146	1	162	0.35	0.39	-0.05	0.39	-0.04	-0.04	1.25	-33.98	-32.31	-0.43	7.50
		154	0.20	0.23	-0.03	0.21	-0.01	0.06	-2.82	-21.59	-19.31	-5.10	6.12
		2	0.35	0.17	-0.15	0.06	-0.04	0.15	-26.00	-40.62	-32.71	-33.91	7.29
		43	0.59	0.31	-0.30	-7.10e-03	0.01	0.30	-25.25	-68.40	-57.16	-36.49	18.94
146	2	162	0.25	0.28	-0.03	0.28	-0.03	-0.03	0.95	-24.33	-23.03	-0.36	5.59
		154	0.14	0.16	-0.02	0.15	-0.01	0.04	-1.95	-15.41	-13.62	-3.74	4.57
		2	0.25	0.12	-0.11	0.04	-0.03	0.11	-17.67	-29.49	-23.19	-23.97	5.90
		43	0.43	0.22	-0.21	-4.87e-03	9.73e-03	0.22	-17.18	-49.34	-40.69	-25.83	14.26

146	19	162	0.52	0.39	-0.09	0.39	-0.09	-0.04	-36.43	-61.67	-50.97	-47.12	-12.47
		154	0.34	0.22	-0.27	0.22	-0.27	-0.04	-11.02	-39.29	-34.40	-15.92	-10.70
		2	0.55	0.08	-0.38	-1.57e-04	-0.31	-0.17	1.37	-55.55	-25.26	-28.92	28.40
		43	0.79	0.01	-0.09	-0.02	-0.06	-0.05	-23.17	-91.21	-48.31	-66.07	32.84
146	35	162	0.26	0.28	-0.07	0.26	-0.05	-0.09	-5.21	-28.26	-27.90	-5.57	2.84
		154	0.16	0.11	-0.11	0.11	-0.11	-5.76e-03	-0.84	-16.60	-16.56	-0.88	0.76
		2	0.35	0.09	-0.11	0.09	-0.11	-0.02	-10.18	-40.56	-31.98	-18.76	13.68
		43	0.55	0.12	-0.06	0.05	0.01	0.08	-15.49	-63.63	-49.31	-29.81	22.01
147	1	161	0.47	0.49	-0.07	0.48	-0.07	0.03	1.46	-45.98	-45.33	0.81	-5.50
		155	0.55	0.98	0.05	0.97	0.06	0.07	0.52	-53.55	-53.06	0.03	-5.12
		5	0.87	0.85	-0.62	0.42	-0.20	-0.66	-26.76	-99.10	-81.16	-44.69	-31.23
		41	0.67	1.10	-0.27	0.69	0.13	-0.63	-41.29	-80.21	-74.14	-47.36	-14.12
147	2	161	0.34	0.35	-0.05	0.35	-0.05	0.02	1.08	-32.80	-32.30	0.59	-4.08
		155	0.40	0.70	0.04	0.70	0.04	0.05	0.49	-38.25	-37.88	0.11	-3.81
		5	0.62	0.60	-0.44	0.30	-0.14	-0.47	-18.74	-70.87	-57.88	-31.73	-22.55
		41	0.48	0.78	-0.20	0.49	0.10	-0.45	-29.08	-57.31	-52.72	-33.67	-10.42
147	34	161	0.53	0.36	-0.01	0.34	0.01	-0.09	43.88	-16.26	-16.21	43.83	1.69
		155	0.34	0.73	0.08	0.73	0.09	-0.04	4.20	-29.85	-29.77	4.12	-1.58
		5	1.18	0.95	-0.56	0.52	-0.12	-0.68	13.35	-112.74	-70.36	-29.03	-59.56
		41	0.96	1.21	-0.27	0.74	0.20	-0.69	32.79	-77.18	-53.89	9.50	-44.93
147	66	161	0.38	0.37	-0.03	0.37	-0.02	-0.02	18.49	-24.82	-24.74	18.42	-1.75
		155	0.36	0.75	0.06	0.75	0.06	0.02	2.04	-33.89	-33.63	1.77	-3.09
		5	0.83	0.77	-0.51	0.40	-0.14	-0.58	-4.65	-86.53	-62.20	-28.98	-37.42
		41	0.61	0.99	-0.24	0.61	0.14	-0.57	-1.49	-63.03	-50.42	-14.10	-24.83
148	1	159	0.73	0.42	-0.02	0.42	-0.02	0.01	-0.59	-74.90	-74.87	-0.62	1.64
		156	0.59	0.27	0.04	0.27	0.05	-0.02	5.89	-57.01	-53.55	2.43	14.32
		7	0.76	0.68	-0.18	0.63	-0.14	0.19	-13.03	-84.27	-63.17	-34.13	32.53
		25	0.73	0.68	0.04	0.68	0.04	-0.03	-20.40	-81.40	-71.31	-30.49	22.67
148	2	159	0.54	0.29	-0.01	0.29	-0.01	6.94e-03	-0.35	-54.71	-54.68	-0.39	1.36
		156	0.42	0.19	0.03	0.19	0.03	-0.02	4.25	-40.77	-38.21	1.69	10.42
		7	0.55	0.48	-0.13	0.45	-0.10	0.13	-8.36	-60.77	-44.97	-24.16	24.05
		25	0.53	0.49	0.03	0.49	0.03	-0.02	-14.45	-59.25	-51.95	-21.76	16.55
148	7	159	0.87	0.07	-0.02	0.05	3.77e-03	-0.04	-2.54	-91.50	-89.91	-4.13	11.77
		156	0.64	0.15	-0.06	-0.03	0.13	-0.06	-1.51	-67.07	-64.84	-3.74	11.88
		7	0.83	0.29	-0.05	0.24	-0.01	0.11	-17.84	-93.93	-83.68	-28.09	25.97
		25	0.98	0.28	0.04	0.27	0.05	-0.05	-18.36	-109.31	-99.55	-28.12	28.15
148	39	159	0.71	0.20	-6.26e-03	0.20	-5.58e-03	-0.01	-1.23	-73.63	-73.11	-1.76	6.12
		156	0.50	0.13	0.05	0.11	0.08	-0.04	1.62	-50.37	-47.90	-0.84	11.04
		7	0.66	0.42	-0.10	0.39	-0.07	0.13	-10.72	-72.69	-59.63	-23.77	25.27
		25	0.76	0.43	0.04	0.42	0.04	-0.04	-15.84	-84.11	-75.61	-24.35	22.54
149	1	158	1.94	1.28	-7.55e-03	1.28	-7.19e-03	0.02	2.91	-195.41	-195.27	2.76	-5.37
		157	1.58	0.36	-0.02	0.36	-0.02	0.01	0.40	-162.65	-162.07	-0.18	9.74
		22	1.45	0.40	0.09	0.36	0.13	-0.10	-25.14	-160.40	-159.49	-26.06	11.08
		24	1.92	1.02	-0.33	0.75	-0.06	0.54	-37.81	-213.42	-213.23	-38.00	5.87
149	2	158	1.42	0.93	-4.89e-03	0.93	-4.68e-03	0.01	2.10	-142.54	-142.44	2.00	-3.79
		157	1.16	0.27	-0.01	0.27	-0.01	0.01	0.32	-119.53	-119.15	-0.07	6.75
		22	1.06	0.28	0.07	0.26	0.09	-0.06	-18.12	-117.85	-117.29	-18.68	7.45
		24	1.40	0.73	-0.23	0.55	-0.04	0.38	-26.69	-155.50	-155.38	-26.82	4.00
149	25	158	1.70	1.28	0.02	1.28	0.03	0.03	2.45	-170.61	-170.60	2.44	-0.83
		157	1.44	0.58	0.04	0.58	0.04	4.18e-03	-0.63	-147.93	-146.88	-1.68	12.40
		22	1.31	0.54	0.13	0.53	0.14	-0.05	-19.54	-143.38	-142.16	-20.76	12.25
		24	1.67	1.01	-0.19	0.85	-0.02	0.42	-25.93	-182.38	-182.09	-26.23	6.83
149	57	158	1.64	1.13	7.59e-03	1.13	7.94e-03	0.02	2.32	-164.53	-164.49	2.28	-2.42
		157	1.37	0.42	6.51e-03	0.42	6.84e-03	0.01	-0.07	-141.13	-140.56	-0.63	8.92
		22	1.26	0.40	0.10	0.39	0.11	-0.05	-19.34	-138.02	-137.34	-20.01	8.90
		24	1.62	0.88	-0.21	0.71	-0.04	0.40	-26.44	-177.67	-177.48	-26.63	5.38

150	1	160	0.23	0.83	-0.03	0.83	-0.03	-1.64e-03	0.79	-20.82	-15.50	-4.54	-9.32
		158	1.58	1.44	0.06	1.44	0.07	-0.08	6.13	-155.37	-154.66	5.42	10.69
		24	1.61	1.26	-0.35	1.24	-0.33	0.19	-29.32	-175.55	-169.20	-35.67	29.80
		27	0.27	1.62	0.13	1.52	0.23	-0.37	1.23	-23.83	-0.18	-22.41	-5.79
150	2	160	0.16	0.59	-0.02	0.59	-0.02	-9.93e-04	0.59	-14.70	-10.78	-3.32	-6.67
		158	1.15	1.04	0.04	1.04	0.05	-0.06	4.38	-113.18	-112.71	3.91	7.43
		24	1.17	0.91	-0.25	0.90	-0.23	0.13	-20.59	-127.37	-122.95	-25.01	21.28
		27	0.19	1.17	0.09	1.09	0.16	-0.27	1.67	-16.56	0.43	-15.32	-4.59
150	25	160	0.27	0.94	-0.02	0.94	-0.01	0.07	-4.15	-26.60	-21.76	-9.00	-9.24
		158	1.38	1.42	0.08	1.41	0.09	-0.12	4.79	-135.85	-135.71	4.64	4.48
		24	1.39	1.17	-0.22	1.17	-0.22	0.08	-20.55	-149.64	-146.05	-24.14	21.21
		27	0.22	1.41	0.10	1.37	0.14	-0.21	-4.77	-23.25	-8.60	-19.43	-7.49
150	57	160	0.21	0.77	-0.02	0.77	-0.02	0.03	-1.53	-20.02	-15.69	-5.86	-7.83
		158	1.32	1.24	0.06	1.23	0.06	-0.09	4.65	-130.54	-130.27	4.38	6.09
		24	1.35	1.07	-0.24	1.06	-0.23	0.12	-20.19	-144.82	-140.66	-24.35	22.40
		27	0.21	1.33	0.10	1.27	0.15	-0.26	0.10	-18.96	-2.56	-16.30	-6.61
151	1	155	0.83	0.89	0.07	0.89	0.07	9.99e-03	9.05	-78.18	-75.09	5.97	-16.11
		160	0.26	1.00	-0.03	0.99	-0.03	0.04	-3.53	-24.85	-24.59	-3.78	2.32
		27	0.34	1.36	0.09	1.31	0.14	0.24	-3.22	-33.73	-15.42	-21.53	-14.94
		5	1.00	1.13	-0.44	1.00	-0.31	-0.43	-24.67	-113.24	-90.76	-47.14	-38.54
151	2	155	0.59	0.64	0.05	0.64	0.05	7.39e-03	6.47	-55.50	-53.27	4.24	-11.53
		160	0.19	0.71	-0.02	0.71	-0.02	0.03	-2.57	-17.72	-17.58	-2.71	1.44
		27	0.24	0.97	0.07	0.94	0.10	0.17	-1.68	-24.06	-11.00	-14.74	-11.03
		5	0.71	0.80	-0.32	0.71	-0.23	-0.30	-17.09	-80.69	-64.36	-33.42	-27.79
151	18	155	0.73	0.71	0.08	0.71	0.08	0.02	2.52	-72.57	-70.15	0.09	-13.28
		160	0.40	0.78	-0.02	0.78	-0.01	0.08	-3.71	-39.73	-37.99	-5.44	-7.71
		27	0.51	1.09	0.08	1.05	0.13	0.21	-4.04	-51.01	-37.07	-17.97	-21.46
		5	0.90	0.87	-0.30	0.78	-0.21	-0.31	-22.79	-101.57	-88.04	-36.31	-29.71
151	50	155	0.64	0.70	0.06	0.70	0.06	0.01	4.72	-61.67	-59.40	2.44	-12.08
		160	0.28	0.78	-0.02	0.77	-0.02	0.05	-3.46	-27.79	-27.44	-3.82	-2.92
		27	0.37	1.07	0.08	1.04	0.12	0.19	-2.15	-36.51	-22.98	-15.69	-16.79
		5	0.79	0.86	-0.32	0.77	-0.23	-0.32	-18.44	-88.60	-73.78	-33.26	-28.64
152	1	157	1.15	0.47	0.02	0.46	0.02	0.03	1.32	-117.05	-117.05	1.32	-0.37
		159	0.74	0.37	-5.90e-03	0.37	-5.46e-03	-0.01	1.14	-75.06	-73.16	-0.77	11.90
		25	0.68	0.74	0.01	0.74	0.02	0.08	-26.04	-77.32	-72.03	-31.33	15.60
		22	1.17	0.68	-0.05	0.68	-0.05	-0.04	-21.04	-128.42	-127.13	-22.33	11.71
152	2	157	0.85	0.33	0.01	0.33	0.01	0.02	1.07	-86.78	-86.78	1.07	-0.18
		159	0.54	0.26	-4.11e-03	0.26	-3.77e-03	-9.42e-03	0.78	-54.82	-53.48	-0.57	8.54
		25	0.49	0.53	0.01	0.53	0.02	0.05	-18.45	-56.29	-52.38	-22.36	11.52
		22	0.87	0.49	-0.03	0.49	-0.03	-0.02	-15.20	-94.67	-93.88	-15.99	7.90
152	8	157	1.20	0.13	-0.06	0.13	-0.06	7.69e-03	0.21	-123.71	-123.71	0.21	-0.06
		159	0.81	0.13	-0.04	0.06	0.03	0.08	-0.99	-84.67	-82.63	-3.03	12.89
		25	0.72	0.61	0.03	0.55	0.09	0.18	-17.86	-80.33	-75.25	-22.94	17.08
		22	1.16	0.49	-0.06	0.49	-0.06	-3.98e-03	-16.07	-125.50	-125.06	-16.51	6.90
152	40	157	1.08	0.26	-0.02	0.26	-0.02	0.02	0.91	-110.64	-110.64	0.91	0.18
		159	0.69	0.18	6.17e-03	0.18	0.01	0.03	0.02	-71.08	-69.49	-1.57	10.52
		25	0.62	0.58	0.03	0.56	0.05	0.10	-17.91	-69.99	-65.31	-22.58	14.88
		22	1.06	0.52	-0.04	0.52	-0.04	-6.94e-03	-15.94	-115.72	-115.20	-16.46	7.20
153	1	156	0.45	0.43	0.03	0.42	0.04	-0.08	-0.75	-45.20	-44.06	-1.88	7.01
		162	0.35	0.19	-0.06	0.18	-0.06	-0.02	0.97	-34.94	-33.44	-0.53	7.19
		43	0.57	0.58	-0.07	0.41	0.10	0.28	-23.52	-66.90	-54.75	-35.68	19.48
		7	0.74	0.47	-0.35	0.27	-0.15	0.36	-12.43	-81.23	-60.17	-33.49	31.71
153	2	156	0.32	0.30	0.02	0.29	0.03	-0.05	-0.45	-32.46	-31.58	-1.33	5.24
		162	0.25	0.13	-0.04	0.13	-0.04	-0.02	0.75	-25.02	-23.84	-0.43	5.37
		43	0.41	0.41	-0.05	0.29	0.07	0.20	-15.92	-48.26	-38.94	-25.24	14.65
		7	0.54	0.34	-0.25	0.19	-0.11	0.25	-8.09	-58.66	-43.03	-23.72	23.37

153	25	156	0.25	0.20	0.08	0.20	0.08	1.03e-03	12.66	-16.72	-14.10	10.04	8.36
		162	0.44	0.11	-0.07	0.03	0.01	0.09	46.20	0.78	1.25	45.72	4.62
		43	0.99	0.77	-0.05	0.52	0.19	0.38	52.85	-64.08	-33.39	22.15	51.45
		7	1.14	0.63	-0.27	0.40	-0.03	0.39	34.59	-95.71	-47.91	-13.21	62.80
153	57	156	0.27	0.28	0.05	0.27	0.05	-0.03	4.88	-24.78	-23.11	3.21	6.85
		162	0.27	0.10	-0.03	0.10	-0.02	0.03	19.38	-12.88	-11.98	18.49	5.30
		43	0.61	0.58	-0.05	0.40	0.13	0.28	16.04	-52.42	-33.05	-3.32	30.83
		7	0.77	0.47	-0.27	0.29	-0.08	0.32	11.69	-72.32	-43.30	-17.33	39.95
154	1	153	0.28	0.46	-0.08	0.45	-0.06	-0.08	-3.79	-29.60	-28.69	-4.71	-4.77
		161	0.48	0.88	-0.04	0.88	-0.03	0.05	1.89	-44.86	-44.05	1.07	-6.11
		41	0.70	0.58	-0.71	-0.11	-0.03	-0.65	-42.87	-81.35	-76.03	-48.20	-13.29
		1	0.43	0.51	-0.36	0.10	0.05	-0.43	-43.36	-45.01	-44.07	-44.30	-0.81
154	2	153	0.20	0.33	-0.05	0.32	-0.05	-0.06	-2.71	-21.04	-20.34	-3.41	-3.52
		161	0.34	0.63	-0.03	0.63	-0.02	0.04	1.39	-32.01	-31.38	0.77	-4.51
		41	0.50	0.41	-0.51	-0.08	-0.02	-0.46	-30.22	-58.15	-54.10	-34.28	-9.84
		1	0.30	0.36	-0.26	0.07	0.04	-0.31	-30.43	-32.38	-31.29	-31.52	-0.97
154	12	153	0.34	0.33	-0.27	0.32	-0.27	0.04	4.55	-31.65	-30.01	2.90	7.55
		161	0.43	0.73	-0.09	0.69	-0.06	0.16	-9.23	-45.85	-45.58	-9.50	3.13
		41	0.83	0.18	-0.20	0.02	-0.04	-0.18	-39.22	-98.72	-86.46	-51.48	-24.07
		1	0.56	0.15	-0.17	0.14	-0.16	-0.04	-22.49	-65.73	-61.25	-26.96	-13.17
154	44	153	0.24	0.34	-0.14	0.34	-0.14	-0.02	-0.84	-23.41	-23.36	-0.89	1.10
		161	0.36	0.70	-0.05	0.69	-0.04	0.09	-3.70	-36.46	-36.41	-3.76	-1.36
		41	0.62	0.33	-0.40	-0.04	-0.03	-0.37	-32.19	-72.61	-64.87	-39.93	-15.90
		1	0.38	0.25	-0.20	0.10	-0.04	-0.21	-25.31	-44.88	-41.97	-28.22	-6.97
155	1	48	0.59	0.51	-0.48	0.08	-0.05	-0.49	-37.11	-69.17	-43.31	-62.97	-12.66
		180	0.48	0.51	-0.01	-0.01	0.51	0.02	1.68	-46.55	0.90	-45.78	-6.08
		173	0.25	0.17	-0.07	-0.07	0.17	-0.01	-4.55	-27.00	-5.69	-25.85	-4.94
		3	0.35	0.49	-0.18	0.18	0.14	-0.33	-27.60	-40.85	-34.69	-33.76	-6.61
155	2	48	0.42	0.37	-0.34	0.06	-0.04	-0.35	-25.85	-49.58	-30.94	-44.49	-9.74
		180	0.34	0.36	-7.73e-03	-7.44e-03	0.36	0.01	1.25	-32.94	0.63	-32.33	-4.55
		173	0.17	0.12	-0.05	-0.05	0.12	-8.54e-03	-3.22	-19.02	-4.14	-18.10	-3.70
		3	0.25	0.35	-0.13	0.13	0.10	-0.24	-18.80	-29.66	-24.70	-23.75	-5.41
155	29	48	0.77	0.13	0.04	0.07	0.10	-0.04	-32.31	-90.65	-44.43	-78.54	-23.67
		180	0.46	0.46	-0.06	-0.02	0.42	0.13	-9.63	-50.67	-10.02	-50.29	3.94
		173	0.36	0.14	-0.30	-0.27	0.12	0.10	6.80	-33.17	5.17	-31.54	7.90
		3	0.57	0.21	-0.08	-0.06	0.20	0.06	-9.23	-61.96	-16.16	-55.03	-17.81
155	37	48	0.38	0.45	-0.33	0.11	8.10e-03	-0.39	-12.24	-43.01	-14.16	-41.08	-7.45
		180	0.38	0.31	6.47e-03	0.01	0.31	0.04	19.86	-24.33	17.04	-21.51	-10.79
		173	0.17	0.05	-0.01	-8.00e-03	0.05	-0.01	6.87	-13.09	2.73	-8.95	-8.09
		3	0.22	0.46	-0.10	0.20	0.16	-0.28	-16.11	-26.29	-17.00	-25.40	-2.87
156	1	82	0.94	0.99	-0.57	-0.42	0.84	-0.47	-31.79	-108.25	-40.15	-99.89	-23.86
		164	0.86	1.11	0.07	0.07	1.11	0.02	1.53	-84.65	1.36	-84.47	-3.88
		175	0.72	0.67	-0.06	-0.05	0.67	-0.04	4.17	-70.51	3.13	-69.48	-8.74
		12	0.72	0.92	-0.43	0.14	0.34	-0.66	-37.57	-86.00	-43.28	-80.29	-15.61
156	2	82	0.67	0.70	-0.41	-0.30	0.59	-0.33	-22.47	-77.16	-28.76	-70.87	-17.44
		164	0.61	0.79	0.05	0.05	0.79	0.01	1.18	-60.19	1.04	-60.05	-2.92
		175	0.51	0.48	-0.04	-0.04	0.48	-0.03	3.01	-49.99	2.22	-49.20	-6.41
		12	0.52	0.65	-0.30	0.10	0.24	-0.47	-26.33	-61.43	-30.91	-56.86	-11.82
156	29	82	1.27	0.38	-0.55	-0.38	0.21	-0.36	-32.00	-144.19	-33.61	-142.59	-13.33
		164	0.96	0.75	0.07	0.08	0.74	0.07	2.84	-95.86	2.47	-95.49	-6.02
		175	0.78	0.48	0.07	0.12	0.43	0.13	-15.34	-85.76	-15.37	-85.72	1.47
		12	1.06	0.48	-0.41	0.20	-0.13	-0.42	-51.98	-126.81	-52.46	-126.34	5.93
156	51	82	0.92	0.61	-0.55	-0.36	0.42	-0.42	-26.71	-105.82	-32.25	-100.28	-20.20
		164	0.77	0.83	0.06	0.06	0.83	1.29e-03	-0.11	-77.45	-0.60	-76.96	-6.10
		175	0.61	0.52	0.08	0.08	0.52	0.01	-2.32	-62.78	-2.87	-62.23	-5.75
		12	0.70	0.65	-0.39	0.19	0.07	-0.52	-33.74	-82.86	-35.49	-81.11	-9.09

157	1	46	0.57	0.87	-0.19	0.16	0.51	0.50	-37.16	-68.18	-42.90	-62.44	12.05
		179	0.47	0.24	3.51e-03	5.24e-03	0.24	-0.02	1.76	-46.98	0.91	-46.13	6.37
		174	0.66	0.62	-0.02	-0.01	0.61	0.07	1.61	-65.61	1.14	-65.14	5.63
		10	0.72	0.79	-0.25	0.15	0.39	0.51	-34.50	-85.43	-42.14	-77.80	18.18
157	2	46	0.41	0.62	-0.14	0.12	0.36	0.36	-25.91	-48.86	-30.65	-44.12	9.29
		179	0.33	0.17	2.70e-03	3.88e-03	0.17	-0.01	1.30	-33.23	0.64	-32.57	4.75
		174	0.47	0.44	-0.01	-8.09e-03	0.44	0.05	1.20	-46.51	0.82	-46.14	4.21
		10	0.51	0.56	-0.18	0.11	0.27	0.36	-24.12	-61.08	-30.11	-55.10	13.62
157	8	46	0.79	0.90	-0.10	0.25	0.56	0.47	29.16	-61.72	8.55	-41.12	38.06
		179	0.46	0.14	-0.09	0.06	-4.17e-03	0.11	39.95	-12.80	39.63	-12.48	4.09
		174	0.41	0.36	0.04	0.10	0.30	0.13	13.52	-33.23	12.46	-32.17	6.96
		10	0.89	0.68	0.08	0.29	0.47	0.28	8.43	-87.71	-19.83	-59.45	43.80
157	39	46	0.50	0.72	-0.11	0.17	0.44	0.39	-1.08	-51.92	-13.25	-39.74	21.70
		179	0.36	0.11	0.01	0.02	0.10	0.03	16.64	-25.48	16.15	-25.00	4.50
		174	0.44	0.42	0.04	0.05	0.40	0.08	5.24	-42.00	4.67	-41.43	5.15
		10	0.63	0.61	-0.05	0.20	0.35	0.32	-10.74	-70.03	-25.06	-55.70	25.38
158	1	84	1.02	0.98	-0.46	-0.42	0.95	0.21	-29.18	-114.72	-40.51	-103.39	29.00
		165	0.93	1.11	0.07	0.07	1.11	-0.03	5.36	-89.68	4.01	-88.34	11.23
		176	0.77	0.94	-0.03	-0.03	0.94	-0.02	0.28	-75.93	0.07	-75.71	-4.02
		34	0.59	1.21	0.20	0.24	1.16	-0.21	-38.08	-65.51	-39.68	-63.91	6.43
158	2	84	0.72	0.69	-0.33	-0.31	0.67	0.15	-20.57	-81.69	-28.99	-73.27	21.07
		165	0.66	0.79	0.05	0.05	0.79	-0.02	3.86	-63.72	2.88	-62.74	8.08
		176	0.55	0.67	-0.02	-0.02	0.67	-0.02	0.25	-54.14	0.10	-54.00	-2.80
		34	0.42	0.85	0.14	0.18	0.82	-0.15	-27.21	-46.69	-28.31	-45.58	4.51
158	25	84	1.00	0.67	-0.35	-0.33	0.65	0.14	-22.26	-111.63	-31.27	-102.61	26.91
		165	0.95	0.92	0.08	0.09	0.92	-0.04	0.43	-95.18	-1.04	-93.72	11.76
		176	0.85	0.77	-0.06	-0.05	0.76	0.06	-6.99	-88.26	-6.99	-88.26	-0.28
		34	0.68	0.80	0.14	0.14	0.79	-0.07	-34.65	-77.99	-36.20	-76.44	8.05
158	57	84	0.86	0.71	-0.35	-0.33	0.69	0.15	-20.88	-96.03	-29.66	-87.25	24.14
		165	0.80	0.88	0.07	0.07	0.88	-0.03	2.52	-78.03	1.37	-76.88	9.55
		176	0.70	0.73	-0.04	-0.04	0.73	0.01	-2.67	-71.00	-2.70	-70.96	-1.56
		34	0.54	0.86	0.15	0.17	0.83	-0.13	-30.90	-61.91	-32.20	-60.61	6.22
159	1	12	0.72	0.79	-0.25	0.15	0.39	-0.51	-34.50	-85.43	-42.14	-77.80	-18.18
		175	0.66	0.62	-0.02	-0.01	0.61	-0.07	1.61	-65.61	1.14	-65.14	-5.63
		180	0.47	0.24	3.51e-03	5.24e-03	0.24	0.02	1.76	-46.98	0.91	-46.13	-6.37
		48	0.57	0.87	-0.19	0.16	0.51	-0.50	-37.16	-68.18	-42.90	-62.44	-12.05
159	2	12	0.51	0.56	-0.18	0.11	0.27	-0.36	-24.12	-61.08	-30.11	-55.10	-13.62
		175	0.47	0.44	-0.01	-8.09e-03	0.44	-0.05	1.20	-46.51	0.82	-46.14	-4.21
		180	0.33	0.17	2.70e-03	3.88e-03	0.17	0.01	1.30	-33.23	0.64	-32.57	-4.75
		48	0.41	0.62	-0.14	0.12	0.36	-0.36	-25.91	-48.86	-30.65	-44.12	-9.29
159	29	12	0.56	0.29	-4.02e-03	0.24	0.05	-0.11	-38.78	-66.72	-40.17	-65.32	-6.08
		175	0.86	0.49	0.16	0.16	0.48	0.05	-19.02	-95.81	-19.29	-95.55	4.53
		180	0.72	0.24	-0.12	-0.03	0.14	0.16	-17.91	-81.13	-17.98	-81.06	-2.11
		48	0.46	0.11	0.03	0.05	0.10	-0.03	-32.33	-54.96	-37.08	-50.21	-9.22
159	61	12	0.51	0.45	-0.10	0.17	0.19	-0.27	-29.49	-61.00	-33.02	-57.46	-9.94
		175	0.61	0.48	0.06	0.06	0.48	-0.01	-7.74	-65.67	-7.74	-65.66	-0.68
		180	0.47	0.20	-0.04	-8.96e-03	0.17	0.08	-7.10	-51.73	-7.42	-51.41	-3.76
		48	0.41	0.43	-0.07	0.09	0.27	-0.24	-26.20	-48.54	-31.89	-42.85	-9.73
160	1	2	0.35	0.49	-0.18	0.18	0.14	0.33	-27.60	-40.85	-34.69	-33.76	6.61
		172	0.25	0.17	-0.07	-0.07	0.17	0.01	-4.55	-27.00	-5.69	-25.85	4.94
		179	0.48	0.51	-0.01	-0.01	0.51	-0.02	1.68	-46.55	0.90	-45.78	6.08
		46	0.59	0.51	-0.48	0.08	-0.05	0.49	-37.11	-69.17	-43.31	-62.97	12.66
160	2	2	0.25	0.35	-0.13	0.13	0.10	0.24	-18.80	-29.66	-24.70	-23.75	5.41
		172	0.17	0.12	-0.05	-0.05	0.12	8.54e-03	-3.22	-19.02	-4.14	-18.10	3.70
		179	0.34	0.36	-7.73e-03	-7.44e-03	0.36	-0.01	1.25	-32.94	0.63	-32.33	4.55
		46	0.42	0.37	-0.34	0.06	-0.04	0.35	-25.85	-49.58	-30.94	-44.49	9.74

160	31	2	0.57	0.21	-0.08	-0.06	0.20	-0.06	-9.23	-61.96	-16.16	-55.03	17.81
		172	0.36	0.14	-0.30	-0.27	0.12	-0.10	6.80	-33.17	5.17	-31.54	-7.90
		179	0.46	0.46	-0.06	-0.02	0.42	-0.13	-9.63	-50.67	-10.02	-50.29	-3.94
		46	0.77	0.13	0.04	0.07	0.10	0.04	-32.31	-90.65	-44.43	-78.54	23.67
160	63	2	0.35	0.23	-0.03	0.05	0.14	0.12	-12.60	-41.14	-19.44	-34.31	12.18
		172	0.22	0.13	-0.15	-0.14	0.13	-0.04	-0.37	-22.20	-0.42	-22.15	-1.06
		179	0.37	0.41	-0.02	-0.01	0.40	-0.06	-4.06	-38.43	-4.09	-38.40	1.06
		46	0.54	0.28	-0.20	0.06	0.02	0.24	-26.03	-64.00	-35.11	-54.92	16.20
161	1	10	0.72	0.92	-0.43	0.14	0.34	0.66	-37.57	-86.00	-43.28	-80.29	15.61
		174	0.72	0.67	-0.06	-0.05	0.67	0.04	4.17	-70.51	3.13	-69.48	8.74
		165	0.86	1.11	0.07	0.07	1.11	-0.02	1.53	-84.65	1.36	-84.47	3.88
		84	0.94	0.99	-0.57	-0.42	0.84	0.47	-31.79	-108.25	-40.15	-99.89	23.86
161	2	10	0.52	0.65	-0.30	0.10	0.24	0.47	-26.33	-61.43	-30.91	-56.86	11.82
		174	0.51	0.48	-0.04	-0.04	0.48	0.03	3.01	-49.99	2.22	-49.20	6.41
		165	0.61	0.79	0.05	0.05	0.79	-0.01	1.18	-60.19	1.04	-60.05	2.92
		84	0.67	0.70	-0.41	-0.30	0.59	0.33	-22.47	-77.16	-28.76	-70.87	17.44
161	31	10	1.06	0.48	-0.41	0.20	-0.13	0.42	-51.98	-126.81	-52.46	-126.34	-5.93
		174	0.78	0.48	0.07	0.12	0.43	-0.13	-15.34	-85.76	-15.37	-85.72	-1.47
		165	0.96	0.75	0.07	0.08	0.74	-0.07	2.84	-95.86	2.47	-95.49	6.02
		84	1.27	0.38	-0.55	-0.38	0.21	0.36	-32.00	-144.19	-33.61	-142.59	13.33
161	63	10	0.71	0.59	-0.35	0.15	0.10	0.47	-38.16	-84.68	-38.50	-84.34	3.95
		174	0.60	0.48	0.02	0.03	0.48	-0.04	-5.19	-63.47	-5.35	-63.31	3.09
		165	0.77	0.81	0.06	0.07	0.81	-0.04	2.11	-76.06	1.88	-75.83	4.28
		84	0.93	0.59	-0.49	-0.35	0.45	0.36	-26.96	-106.02	-30.30	-102.68	15.91
162	1	34	0.59	1.21	0.20	0.24	1.16	0.21	-38.08	-65.51	-39.68	-63.91	-6.43
		176	0.77	0.94	-0.03	-0.03	0.94	0.02	0.28	-75.93	0.07	-75.71	4.02
		164	0.93	1.11	0.07	0.07	1.11	0.03	5.36	-89.68	4.01	-88.34	-11.23
		82	1.02	0.98	-0.46	-0.42	0.95	-0.21	-29.18	-114.72	-40.51	-103.39	-29.00
162	2	34	0.42	0.85	0.14	0.18	0.82	0.15	-27.21	-46.69	-28.31	-45.58	-4.51
		176	0.55	0.67	-0.02	-0.02	0.67	0.02	0.25	-54.14	0.10	-54.00	2.80
		164	0.66	0.79	0.05	0.05	0.79	0.02	3.86	-63.72	2.88	-62.74	-8.08
		82	0.72	0.69	-0.33	-0.31	0.67	-0.15	-20.57	-81.69	-28.99	-73.27	-21.07
162	19	34	0.68	0.80	0.14	0.14	0.79	0.07	-34.65	-77.99	-36.20	-76.44	-8.05
		176	0.85	0.77	-0.06	-0.05	0.76	-0.06	-6.99	-88.26	-6.99	-88.26	0.28
		164	0.95	0.92	0.08	0.09	0.92	0.04	0.43	-95.18	-1.04	-93.72	-11.76
		82	1.00	0.67	-0.35	-0.33	0.65	-0.14	-22.26	-111.63	-31.27	-102.61	-26.91
162	51	34	0.54	0.86	0.15	0.17	0.83	0.13	-30.90	-61.91	-32.20	-60.61	-6.22
		176	0.70	0.73	-0.04	-0.04	0.73	-0.01	-2.67	-71.00	-2.70	-70.96	1.56
		164	0.80	0.88	0.07	0.07	0.88	0.03	2.52	-78.03	1.37	-76.88	-9.55
		82	0.86	0.71	-0.35	-0.33	0.69	-0.15	-20.88	-96.03	-29.66	-87.25	-24.14
163	1	3	0.41	0.38	-0.22	0.15	9.04e-03	-0.29	-20.57	-47.98	-34.00	-34.54	-13.71
		173	0.30	0.21	-0.03	-0.03	0.20	-0.03	-0.59	-30.92	-1.08	-30.43	3.85
		168	0.19	-0.02	-0.05	-0.02	-0.05	0.01	3.48	-18.16	-7.95	-6.74	-10.80
		143	0.25	0.14	0.02	0.14	0.02	-0.02	-0.20	-25.19	-24.85	-0.54	2.90
163	2	3	0.30	0.27	-0.16	0.11	5.95e-03	-0.21	-13.68	-34.87	-24.16	-24.38	-10.59
		173	0.21	0.15	-0.02	-0.02	0.14	-0.02	-0.47	-21.80	-0.80	-21.47	2.62
		168	0.14	-0.01	-0.04	-0.02	-0.04	8.73e-03	2.46	-13.15	-5.76	-4.92	-7.79
		143	0.17	0.10	0.01	0.10	0.02	-0.01	-0.22	-17.87	-17.65	-0.43	1.93
163	19	3	0.06	0.27	-0.06	0.02	0.19	-0.14	3.57	-2.47	1.85	-0.75	-2.72
		173	0.40	0.13	-0.20	-0.17	0.10	0.10	16.04	-30.72	15.39	-30.07	5.49
		168	0.32	-0.04	-0.10	-0.07	-0.08	0.03	4.68	-30.71	-6.68	-19.36	-16.52
		143	0.22	0.24	0.07	0.07	0.23	-0.04	15.67	-9.90	-9.88	15.64	-0.78
163	61	3	0.24	0.28	-0.14	0.04	0.10	-0.21	-5.04	-26.18	-14.75	-16.47	-10.53
		173	0.27	0.14	-0.12	-0.12	0.14	0.02	3.57	-25.47	2.98	-24.89	4.07
		168	0.19	-0.02	-0.05	-0.03	-0.04	0.01	3.17	-17.62	-3.16	-11.29	-9.57
		143	0.12	0.17	0.07	0.11	0.13	-0.05	3.12	-10.50	-10.50	3.12	-0.22

164	1	154	0.25	0.14	0.02	0.14	0.02	0.02	-0.20	-25.19	-24.85	-0.54	-2.90
		170	0.19	-0.02	-0.05	-0.02	-0.05	-0.01	3.48	-18.16	-7.95	-6.74	10.80
		172	0.30	0.21	-0.03	-0.03	0.20	0.03	-0.59	-30.92	-1.08	-30.43	-3.85
		2	0.41	0.38	-0.22	0.15	9.04e-03	0.29	-20.57	-47.98	-34.00	-34.54	13.71
164	2	154	0.17	0.10	0.01	0.10	0.02	0.01	-0.22	-17.87	-17.65	-0.43	-1.93
		170	0.14	-0.01	-0.04	-0.02	-0.04	-8.73e-03	2.46	-13.15	-5.76	-4.92	7.79
		172	0.21	0.15	-0.02	-0.02	0.14	0.02	-0.47	-21.80	-0.80	-21.47	-2.62
		2	0.30	0.27	-0.16	0.11	5.95e-03	0.21	-13.68	-34.87	-24.16	-24.38	10.59
164	29	154	0.19	0.14	-0.19	0.14	-0.19	-7.14e-03	-15.21	-22.05	-20.04	-17.21	-3.11
		170	0.13	0.04	-4.54e-03	0.03	-1.10e-03	0.01	10.09	-4.59	-4.43	9.93	-1.55
		172	0.15	0.32	0.02	0.13	0.21	0.15	-7.08	-17.88	-17.66	-7.30	1.53
		2	0.58	0.38	-0.35	0.21	-0.18	0.31	-18.24	-66.22	-43.75	-40.70	23.94
164	61	154	0.15	0.12	-0.07	0.12	-0.07	5.93e-03	-7.24	-17.49	-17.09	-7.64	-1.98
		170	0.08	3.74e-03	-0.02	3.72e-03	-0.02	-6.52e-04	3.09	-6.78	-5.09	1.41	3.72
		172	0.12	0.21	9.10e-03	0.04	0.18	0.07	-7.99	-13.97	-8.03	-13.93	-0.51
		2	0.42	0.33	-0.24	0.15	-0.07	0.26	-11.99	-47.54	-30.47	-29.06	17.76
165	1	167	0.55	0.92	-0.02	-0.02	0.92	-0.04	3.47	-51.18	2.72	-50.43	6.34
		47	0.71	0.55	-0.77	-0.07	-0.15	0.65	-49.27	-82.20	-53.05	-78.42	10.50
		4	0.43	0.54	-0.37	0.09	0.08	0.45	-43.81	-45.74	-44.58	-44.97	0.94
		182	0.31	0.47	-0.08	-0.07	0.46	0.09	-4.28	-32.58	-4.99	-31.87	4.43
165	2	167	0.39	0.66	-0.02	-0.02	0.66	-0.03	2.51	-36.52	1.95	-35.96	4.66
		47	0.50	0.39	-0.55	-0.05	-0.11	0.47	-34.87	-58.72	-37.82	-55.77	7.85
		4	0.31	0.38	-0.26	0.06	0.05	0.32	-30.76	-32.90	-31.73	-31.94	1.07
		182	0.22	0.34	-0.06	-0.05	0.33	0.06	-3.06	-23.17	-3.61	-22.62	3.27
165	22	167	0.49	0.77	-0.07	-0.04	0.73	-0.17	-7.80	-51.46	-8.04	-51.21	-3.26
		47	0.83	0.12	-0.16	-0.06	0.02	0.13	-42.40	-98.57	-51.89	-89.08	21.04
		4	0.57	0.15	-0.16	-0.16	0.15	2.75e-03	-20.93	-66.77	-24.46	-63.24	12.22
		182	0.39	0.34	-0.30	-0.30	0.34	-0.05	7.26	-35.00	5.62	-33.36	-8.16
165	54	167	0.42	0.73	-0.03	-0.02	0.72	-0.08	-2.38	-41.56	-2.42	-41.52	1.32
		47	0.62	0.29	-0.41	-0.06	-0.06	0.35	-36.56	-72.85	-42.49	-66.92	13.41
		4	0.38	0.25	-0.18	-0.03	0.09	0.20	-24.94	-45.63	-27.36	-43.22	6.64
		182	0.27	0.35	-0.15	-0.15	0.35	0.02	0.23	-26.19	0.14	-26.10	-1.53
166	1	169	0.62	0.88	9.75e-03	0.01	0.88	-0.02	0.59	-60.40	0.41	-60.22	3.28
		81	0.78	0.96	-0.23	-0.18	0.92	-0.22	-23.08	-87.31	-45.77	-64.62	30.70
		11	0.87	1.09	-0.57	-0.47	0.99	0.40	-41.39	-101.80	-52.63	-90.56	23.51
		184	0.71	0.76	0.14	0.14	0.76	-0.02	6.75	-67.99	5.66	-66.91	8.94
166	2	169	0.44	0.63	6.76e-03	7.01e-03	0.63	-0.01	0.50	-43.29	0.37	-43.15	2.46
		81	0.56	0.69	-0.16	-0.13	0.65	-0.16	-16.27	-62.42	-32.46	-46.23	22.02
		11	0.62	0.78	-0.41	-0.34	0.71	0.28	-29.21	-72.76	-37.43	-64.54	17.04
		184	0.51	0.55	0.10	0.10	0.55	-0.01	4.83	-48.55	4.03	-47.76	6.46
166	22	169	0.70	0.49	0.02	0.04	0.47	-0.11	2.35	-69.43	1.87	-68.95	5.86
		81	0.96	0.42	-0.22	-0.13	0.33	-0.23	-31.83	-109.65	-36.52	-104.97	18.52
		11	1.04	0.47	-0.33	-0.27	0.42	0.20	-57.06	-123.41	-57.07	-123.40	0.88
		184	0.67	0.50	0.15	0.25	0.41	-0.16	-11.80	-73.77	-11.80	-73.76	-0.42
166	54	169	0.56	0.59	0.02	0.02	0.59	-0.05	1.46	-54.88	1.19	-54.61	3.89
		81	0.72	0.60	-0.19	-0.13	0.54	-0.20	-24.46	-81.18	-33.56	-72.08	20.82
		11	0.77	0.68	-0.40	-0.33	0.61	0.25	-42.32	-90.61	-44.34	-88.59	9.66
		184	0.56	0.53	0.15	0.17	0.52	-0.07	-2.51	-58.13	-2.73	-57.91	3.48
167	1	166	0.53	0.53	-0.12	-0.12	0.53	0.02	3.65	-51.32	2.84	-50.51	-6.63
		45	0.70	1.08	-0.28	0.17	0.63	-0.64	-49.15	-82.44	-52.57	-79.02	-10.11
		9	0.85	0.76	-0.85	-0.49	0.40	-0.67	-39.61	-99.81	-50.98	-88.44	-23.57
		183	0.66	1.02	0.12	0.14	1.00	0.12	3.85	-62.93	3.34	-62.41	-5.86
167	2	166	0.38	0.38	-0.09	-0.09	0.38	0.01	2.64	-36.62	2.03	-36.01	-4.86
		45	0.50	0.77	-0.20	0.12	0.45	-0.46	-34.81	-58.86	-37.47	-56.20	-7.55
		9	0.61	0.54	-0.61	-0.35	0.28	-0.48	-27.98	-71.33	-36.28	-63.03	-17.06
		183	0.47	0.73	0.09	0.10	0.72	0.09	2.80	-44.97	2.41	-44.58	-4.29

167	15	166	0.52	0.40	-0.06	-0.03	0.38	-0.10	38.97	-20.96	38.89	-20.88	-2.15
		45	0.79	1.12	-0.22	0.22	0.68	-0.63	14.09	-72.81	-1.16	-57.56	-33.06
		9	0.98	0.83	-0.64	-0.30	0.49	-0.62	-1.02	-100.71	-28.56	-73.17	-44.57
		183	0.44	0.74	0.17	0.17	0.74	0.02	12.33	-35.72	11.85	-35.23	-4.82
167	47	166	0.41	0.41	-0.07	-0.07	0.41	-0.04	17.47	-29.22	17.17	-28.92	-3.75
		45	0.55	0.94	-0.22	0.16	0.56	-0.55	-13.18	-61.99	-21.16	-54.01	-18.06
		9	0.73	0.67	-0.65	-0.36	0.38	-0.55	-16.48	-81.74	-31.89	-66.33	-27.71
		183	0.45	0.77	0.13	0.13	0.77	0.06	6.67	-40.46	6.23	-40.02	-4.56
168	1	171	0.66	0.77	8.98e-03	0.01	0.76	0.04	5.43	-62.69	3.09	-60.36	-12.40
		83	0.73	0.99	-0.18	-0.10	0.91	0.30	-24.42	-81.52	-43.60	-62.34	-26.97
		33	0.28	0.86	0.20	0.21	0.86	0.03	-22.57	-31.15	-30.95	-22.77	-1.30
		163	0.28	0.34	-0.03	-0.03	0.34	0.01	-0.59	-27.89	-1.72	-26.75	5.46
168	2	171	0.47	0.55	6.50e-03	8.28e-03	0.54	0.03	3.86	-44.79	2.20	-43.13	-8.83
		83	0.52	0.71	-0.13	-0.07	0.65	0.22	-17.10	-58.23	-30.89	-44.44	-19.42
		33	0.20	0.61	0.15	0.15	0.61	0.02	-16.19	-21.89	-21.75	-16.34	-0.89
		163	0.20	0.23	-0.02	-0.02	0.23	8.65e-03	-0.44	-20.03	-1.21	-19.26	3.80
168	16	171	0.65	0.94	-1.90e-03	4.52e-03	0.93	0.08	-5.45	-66.30	-9.43	-62.32	-15.06
		83	0.69	0.89	-0.21	-0.12	0.80	0.29	-23.65	-77.29	-40.97	-59.98	-25.08
		33	0.30	0.78	0.15	0.15	0.77	-0.07	-24.85	-32.67	-26.84	-30.69	-3.40
		163	0.36	0.61	1.32e-03	0.02	0.59	-0.10	-6.95	-38.18	-6.95	-38.18	-0.32
168	48	171	0.55	0.73	2.79e-03	6.67e-03	0.72	0.05	-0.09	-54.32	-2.57	-51.84	-11.33
		83	0.60	0.81	-0.17	-0.09	0.73	0.26	-19.37	-67.06	-34.63	-51.79	-22.25
		33	0.25	0.70	0.16	0.16	0.70	-0.02	-21.47	-25.58	-23.88	-23.17	-2.03
		163	0.27	0.38	-8.18e-03	-4.90e-03	0.38	-0.04	-3.39	-28.52	-3.53	-28.37	1.91
169	1	184	0.66	1.02	0.12	0.14	1.00	-0.12	3.85	-62.93	3.34	-62.41	5.86
		11	0.85	0.76	-0.85	-0.49	0.40	0.67	-39.61	-99.81	-50.98	-88.44	23.57
		47	0.70	1.08	-0.28	0.17	0.63	0.64	-49.15	-82.44	-52.57	-79.02	10.11
		167	0.53	0.53	-0.12	-0.12	0.53	-0.02	3.65	-51.32	2.84	-50.51	6.63
169	2	184	0.47	0.73	0.09	0.10	0.72	-0.09	2.80	-44.97	2.41	-44.58	4.29
		11	0.61	0.54	-0.61	-0.35	0.28	0.48	-27.98	-71.33	-36.28	-63.03	17.06
		47	0.50	0.77	-0.20	0.12	0.45	0.46	-34.81	-58.86	-37.47	-56.20	7.55
		167	0.38	0.38	-0.09	-0.09	0.38	-0.01	2.64	-36.62	2.03	-36.01	4.86
169	13	184	0.44	0.74	0.17	0.17	0.74	-0.02	12.33	-35.72	11.85	-35.23	4.82
		11	0.98	0.83	-0.64	-0.30	0.49	0.62	-1.02	-100.71	-28.56	-73.17	44.57
		47	0.79	1.12	-0.22	0.22	0.68	0.63	14.09	-72.81	-1.16	-57.56	33.06
		167	0.52	0.40	-0.06	-0.03	0.38	0.10	38.97	-20.96	38.89	-20.88	2.15
169	45	184	0.45	0.77	0.13	0.13	0.77	-0.06	6.67	-40.46	6.23	-40.02	4.56
		11	0.73	0.67	-0.65	-0.36	0.38	0.55	-16.48	-81.74	-31.89	-66.33	27.71
		47	0.55	0.94	-0.22	0.16	0.56	0.55	-13.18	-61.99	-21.16	-54.01	18.06
		167	0.41	0.41	-0.07	-0.07	0.41	0.04	17.47	-29.22	17.17	-28.92	3.75
170	1	181	0.31	0.47	-0.08	-0.07	0.46	-0.09	-4.28	-32.58	-4.99	-31.87	-4.43
		1	0.43	0.54	-0.37	0.09	0.08	-0.45	-43.81	-45.74	-44.58	-44.97	-0.94
		45	0.71	0.55	-0.77	-0.07	-0.15	-0.65	-49.27	-82.20	-53.05	-78.42	-10.50
		166	0.55	0.92	-0.02	-0.02	0.92	0.04	3.47	-51.18	2.72	-50.43	-6.34
170	2	181	0.22	0.34	-0.06	-0.05	0.33	-0.06	-3.06	-23.17	-3.61	-22.62	-3.27
		1	0.31	0.38	-0.26	0.06	0.05	-0.32	-30.76	-32.90	-31.73	-31.94	-1.07
		45	0.50	0.39	-0.55	-0.05	-0.11	-0.47	-34.87	-58.72	-37.82	-55.77	-7.85
		166	0.39	0.66	-0.02	-0.02	0.66	0.03	2.51	-36.52	1.95	-35.96	-4.66
170	24	181	0.39	0.34	-0.30	-0.30	0.34	0.05	7.26	-35.00	5.62	-33.36	8.16
		1	0.57	0.15	-0.16	-0.16	0.15	-2.75e-03	-20.93	-66.77	-24.46	-63.24	-12.22
		45	0.83	0.12	-0.16	-0.06	0.02	-0.13	-42.40	-98.57	-51.89	-89.08	-21.04
		166	0.49	0.77	-0.07	-0.04	0.73	0.17	-7.80	-51.46	-8.04	-51.21	3.26
170	56	181	0.27	0.35	-0.15	-0.15	0.35	-0.02	0.23	-26.19	0.14	-26.10	1.53
		1	0.38	0.25	-0.18	-0.03	0.09	-0.20	-24.94	-45.63	-27.36	-43.22	-6.64
		45	0.62	0.29	-0.41	-0.06	-0.06	-0.35	-36.56	-72.85	-42.49	-66.92	-13.41
		166	0.42	0.73	-0.03	-0.02	0.72	0.08	-2.38	-41.56	-2.42	-41.52	-1.32

171	1	183	0.71	0.76	0.14	0.14	0.76	0.02	6.75	-67.99	5.66	-66.91	-8.94
		9	0.87	1.09	-0.57	-0.47	0.99	-0.40	-41.39	-101.80	-52.63	-90.56	-23.51
		83	0.78	0.96	-0.23	-0.18	0.92	0.22	-23.08	-87.31	-45.77	-64.62	-30.70
		171	0.62	0.88	9.75e-03	0.01	0.88	0.02	0.59	-60.40	0.41	-60.22	-3.28
171	2	183	0.51	0.55	0.10	0.10	0.55	0.01	4.83	-48.55	4.03	-47.76	-6.46
		9	0.62	0.78	-0.41	-0.34	0.71	-0.28	-29.21	-72.76	-37.43	-64.54	-17.04
		83	0.56	0.69	-0.16	-0.13	0.65	0.16	-16.27	-62.42	-32.46	-46.23	-22.02
		171	0.44	0.63	6.76e-03	7.01e-03	0.63	0.01	0.50	-43.29	0.37	-43.15	-2.46
171	24	183	0.67	0.50	0.15	0.25	0.41	0.16	-11.80	-73.77	-11.80	-73.76	0.42
		9	1.04	0.47	-0.33	-0.27	0.42	-0.20	-57.06	-123.41	-57.07	-123.40	-0.88
		83	0.96	0.42	-0.22	-0.13	0.33	0.23	-31.83	-109.65	-36.52	-104.97	-18.52
		171	0.70	0.49	0.02	0.04	0.47	0.11	2.35	-69.43	1.87	-68.95	-5.86
171	56	183	0.56	0.53	0.15	0.17	0.52	0.07	-2.51	-58.13	-2.73	-57.91	-3.48
		9	0.77	0.68	-0.40	-0.33	0.61	-0.25	-42.32	-90.61	-44.34	-88.59	-9.66
		83	0.72	0.60	-0.19	-0.13	0.54	0.20	-24.46	-81.18	-33.56	-72.08	-20.82
		171	0.56	0.59	0.02	0.02	0.59	0.05	1.46	-54.88	1.19	-54.61	-3.89
172	1	163	0.28	0.34	-0.03	-0.03	0.34	-0.01	-0.59	-27.89	-1.72	-26.75	-5.46
		33	0.28	0.86	0.20	0.21	0.86	-0.03	-22.57	-31.15	-30.95	-22.77	1.30
		81	0.73	0.99	-0.18	-0.10	0.91	-0.30	-24.42	-81.52	-43.60	-62.34	26.97
		169	0.66	0.77	8.98e-03	0.01	0.76	-0.04	5.43	-62.69	3.09	-60.36	12.40
172	2	163	0.20	0.23	-0.02	-0.02	0.23	-8.65e-03	-0.44	-20.03	-1.21	-19.26	-3.80
		33	0.20	0.61	0.15	0.15	0.61	-0.02	-16.19	-21.89	-21.75	-16.34	0.89
		81	0.52	0.71	-0.13	-0.07	0.65	-0.22	-17.10	-58.23	-30.89	-44.44	19.42
		169	0.47	0.55	6.50e-03	8.28e-03	0.54	-0.03	3.86	-44.79	2.20	-43.13	8.83
172	14	163	0.36	0.61	1.32e-03	0.02	0.59	0.10	-6.95	-38.18	-6.95	-38.18	0.32
		33	0.30	0.78	0.15	0.15	0.77	0.07	-24.85	-32.67	-26.84	-30.69	3.40
		81	0.69	0.89	-0.21	-0.12	0.80	-0.29	-23.65	-77.29	-40.97	-59.98	25.08
		169	0.65	0.94	-1.90e-03	4.52e-03	0.93	-0.08	-5.45	-66.30	-9.43	-62.32	15.06
172	46	163	0.27	0.38	-8.18e-03	-4.90e-03	0.38	0.04	-3.39	-28.52	-3.53	-28.37	-1.91
		33	0.25	0.70	0.16	0.16	0.70	0.02	-21.47	-25.58	-23.88	-23.17	2.03
		81	0.60	0.81	-0.17	-0.09	0.73	-0.26	-19.37	-67.06	-34.63	-51.79	22.25
		169	0.55	0.73	2.79e-03	6.67e-03	0.72	-0.05	-0.09	-54.32	-2.57	-51.84	11.33
173	1	182	0.38	0.41	-0.01	1.79e-03	0.40	0.08	0.52	-37.84	-0.32	-37.01	-5.60
		4	0.45	0.61	-0.46	0.09	0.06	0.54	-37.05	-52.02	-44.32	-44.75	7.48
		144	0.36	0.40	-4.30e-03	0.38	7.65e-03	0.07	0.82	-35.01	-34.17	-0.02	-5.41
		177	0.22	-0.05	-0.09	-0.07	-0.07	-0.02	4.09	-20.21	-8.29	-7.82	12.15
173	2	182	0.27	0.30	-9.18e-03	1.53e-03	0.29	0.06	0.33	-26.92	-0.24	-26.34	-3.91
		4	0.33	0.44	-0.33	0.06	0.04	0.39	-25.87	-37.47	-31.52	-31.82	5.80
		144	0.25	0.29	-3.20e-03	0.28	5.45e-03	0.05	0.55	-24.88	-24.31	-0.03	-3.78
		177	0.16	-0.04	-0.06	-0.05	-0.05	-0.01	2.91	-14.54	-5.98	-5.64	8.72
173	24	182	0.15	0.45	0.07	0.17	0.35	0.16	-13.02	-15.67	-15.43	-13.26	0.77
		4	0.58	0.52	-0.48	0.19	-0.15	0.47	-30.18	-67.85	-49.96	-48.07	18.81
		144	0.23	0.27	-0.22	0.27	-0.22	6.00e-03	-14.14	-26.34	-25.04	-15.44	-3.76
		177	0.10	-0.04	-0.05	-0.04	-0.05	8.32e-04	9.65	-1.84	-1.79	9.61	0.72
173	56	182	0.18	0.37	0.04	0.07	0.33	0.11	-6.51	-19.99	-6.73	-19.77	-1.71
		4	0.43	0.48	-0.41	0.12	-0.04	0.44	-25.37	-49.50	-37.76	-37.11	12.06
		144	0.22	0.29	-0.09	0.29	-0.09	0.03	-5.90	-24.19	-23.48	-6.60	-3.51
		177	0.10	-0.04	-0.06	-0.05	-0.05	-7.74e-03	4.18	-7.38	-4.09	0.88	5.22
174	1	178	0.22	-0.05	-0.09	-0.07	-0.07	0.02	4.09	-20.21	-8.29	-7.82	-12.15
		153	0.36	0.40	-4.30e-03	0.38	7.65e-03	-0.07	0.82	-35.01	-34.17	-0.02	5.41
		1	0.45	0.61	-0.46	0.09	0.06	-0.54	-37.05	-52.02	-44.32	-44.75	-7.48
		181	0.38	0.41	-0.01	1.79e-03	0.40	-0.08	0.52	-37.84	-0.32	-37.01	5.60
174	2	178	0.16	-0.04	-0.06	-0.05	-0.05	0.01	2.91	-14.54	-5.98	-5.64	-8.72
		153	0.25	0.29	-3.20e-03	0.28	5.45e-03	-0.05	0.55	-24.88	-24.31	-0.03	3.78
		1	0.33	0.44	-0.33	0.06	0.04	-0.39	-25.87	-37.47	-31.52	-31.82	-5.80
		181	0.27	0.30	-9.18e-03	1.53e-03	0.29	-0.06	0.33	-26.92	-0.24	-26.34	3.91

174	22	178	0.10	-0.04	-0.05	-0.04	-0.05	-8.32e-04	9.65	-1.84	-1.79	9.61	-0.72
		153	0.23	0.27	-0.22	0.27	-0.22	-6.00e-03	-14.14	-26.34	-25.04	-15.44	3.76
		1	0.58	0.52	-0.48	0.19	-0.15	-0.47	-30.18	-67.85	-49.96	-48.07	-18.81
		181	0.15	0.45	0.07	0.17	0.35	-0.16	-13.02	-15.67	-15.43	-13.26	-0.77
174	54	178	0.10	-0.04	-0.06	-0.05	-0.05	7.74e-03	4.18	-7.38	-4.09	0.88	-5.22
		153	0.22	0.29	-0.09	0.29	-0.09	-0.03	-5.90	-24.19	-23.48	-6.60	3.51
		1	0.43	0.48	-0.41	0.12	-0.04	-0.44	-25.37	-49.50	-37.76	-37.11	-12.06
		181	0.18	0.37	0.04	0.07	0.33	-0.11	-6.51	-19.99	-6.73	-19.77	1.71

Elem.	Von Mises	N max	N min	N 1	N 2	N 1-2	M max	M min	M 1	M 2	M 1-2
			-39.81	-12.81	-39.45	-11.86		-617.36	-429.17	-477.58	-256.64
	23.28	22.43		9.51	20.65	13.26	491.61		160.12	314.75	256.64

Viene inoltre riportata la verifica della “Gerarchia delle resistenze trave-colonna” per ogni colonna, considerando piede e testa in entrambe le direzioni globali X e Y.

L'insieme delle verifiche sopra riportate è condotto sugli elementi purché dotati di sezione idonea come da tabella seguente:

Azione	SEZIONI GENERICHE	PROFILI SEMPLICI	PROFILI ACCOPPIATI
4.2.3.1 Classificazione automatica	L, doppio T, C, rettangolare cava, circolare cava	Tutti	Da profilo semplice
4.2.3.1 Classificazione di default 2	Circolare		
4.2.3.1 Classificazione di default 3	restanti		
4.2.4.1.2.1 Trazione	si	si	si
4.2.4.1.2.2 Compressione	si	si	si
4.2.4.1.2.4 Taglio	si	si	si
4.2.4.1.2.5 Torsione	si	si	si
Flessione, taglio e forza assiale	si	si	si
4.2.4.1.3.1 Aste compresse	si	si	per elementi ravvicinati e a croce o coppie calastrellate
4.2.4.1.3.2 Travi inflesse	doppio T simmetrica	doppio T	no

Le verifiche sono riportate in tabelle con il significato sotto indicato; le verifiche sono espresse dal rapporto tra l'azione di progetto e la capacità ultima, pertanto la verifica ha esito positivo per rapporti non superiori all'unità.

Asta	Trave	Pilastro	numero dell'elemento			
Stato			codice di verifica per resistenza, stabilità, svergolamento			
Note			sezione e materiali adottati per l'elemento			
V N			(ASTE) verifica come da par. 4.2.4.1.2 per punto (4.2.6) e (4.2.10)			
V V/T			(TRAVI E PILASTRI) verifica di resistenza come da par. 4.2.4.1.2 per azioni taglio-torsione (4.2.16 e 4.2.28)			
V N/M			(TRAVI E PILASTRI) verifica di resistenza come da par. 4.2.4.1.2 per azioni composte (4.2.33) con riduzione per taglio (4.2.40) ove richiesto			
N	M3	M2	V2	V3	T	sollecitazioni di interesse per la verifica
V stab			(ASTE) verifica come da par. 4.2.4.1.3.1 per punto (4.2.41)			
V stab			(TRAVI E PILASTRI) verifica come da par. 4.2.4.1.3 per punti (C4.2.32) o (C4.2.36) (membrature inflesse e compresse senza/con presenza di instabilità flessione-torsionale)			
BetaxL	B22xL	B33xL	lunghezze libere di inflessione (se indicato riferiti al piano di normale 22 o 33 rispettivamente)			
Snellezza			snellezza massima			
Classe			classe del profilo			
Chi mn			coefficiente di riduzione (della capacità) per la modalità di instabilità pertinente			
Rif. cmb			combinazioni in cui si sono rispettivamente attinti i valori di verifica più elevati			

V flst	(TRAVI E PILASTRI) verifica di stabilità come da par. 4.2.4.1.3.2 per punto (4.2.48)
B1-1 x L	Beta1-1 x L: interasse tra i ritegni torsionali
Chi LT	coefficiente di riduzione (della capacità) per la modalità di instabilità flessio-torsionale
Snell adim	Valore della snellezza adimensionale, utilizzato per il controllo previsto al par. 7.5.5
v.Omeg	Valore del rapporto capacità/domanda per l' azione di interesse (momento per travi e azione assiale per aste) utilizzato per l' amplificazione delle azioni
f.Om. N	Fattore di amplificazione delle azioni assiali per travi e colonne (prodotto di 1.1 x Omega x gamma rd materiale); utilizzato come specificato al par. 7.5.5
f.Om. T	Fattore di amplificazione delle azioni (assiali, flettenti e taglianti) per colonne (prodotto di 1.1 x Omega x gamma rd materiale); utilizzato come specificato al par. 7.5.4
V.7.5.4 M Ed	Verifica come prevista al punto 7.5.4 e valore dell' azione flettente
V.7.5.5 N Ed	Verifica come prevista al punto 7.5.5 e valore dell' azione assiale
V.7.5.6 V Ed,G V Ed,M	Verifica come prevista al punto 7.5.6 e valore dei tagli dovuti ai carichi e alla capacità
V.7.5.10 V Ed	Verifica come prevista al punto 7.5.10 e valore dell' azione di taglio
sovr. Xi (Xf, Yi, Yf)	Valore della sovraresistenza come prevista al par. 7.5.4.2 (i valori non sono normalizzati pertanto saranno maggiori uguali a gamma rd in base alla classe di duttilità)

Nel caso in cui λ_S sia minore di 0.2, oppure nel caso in cui la sollecitazione di calcolo NEd sia inferiore a 0.04 Ncr, gli effetti legati ai fenomeni di instabilità sono trascurati, come da paragrafo 4.2.4.1.3.1

Trave	Stato	Note	V V/T	V N/M	V stab	Cl.LamS	22LamS	33	Snell.	Chi mn	V flstLamS	LT	Chi LT	Rif. cmb
5	ok	s=1,m=11	0.02	0.06	0.06	1	1.3	0.8	119.3	0.40	0.06	0.5	0.99	1,1,1,1
6	ok	s=1,m=11	1.56e-03	2.85e-03	3.16e-03	1	0.6	0.4	55.7	0.79	2.85e-03	0.3	1.00	1,1,17,1
7	ok	s=1,m=11	1.56e-03	2.85e-03	3.17e-03	1	0.6	0.4	55.7	0.79	2.85e-03	0.3	1.00	1,1,7,1
8	ok	s=1,m=11	0.02	0.06	0.06	1	1.3	0.8	119.3	0.40	0.06	0.5	0.99	1,1,1,1

Trave	V V/T	V N/M	V stab	LamS	22LamS	33	Snell.	Chi mn	V flstLamS	LT	Chi LT
	0.02	0.06	0.06	1.27	0.79	119.33		0.40	0.06	0.50	0.99

Trave	v.Omeg	f.Om. N	Stato	V N/M	V stab	Rif. cmb	V[7.5.4]	M Ed	V[7.5.5]	N Ed	V[7.5.6]	V Ed,G	V Ed,M
								daN cm		daN		daN	daN
5							0.0	0.0	0.0	0.0	0.0	0.0	0.0
6							0.0	0.0	0.0	0.0	0.0	0.0	0.0
7							0.0	0.0	0.0	0.0	0.0	0.0	0.0
8							0.0	0.0	0.0	0.0	0.0	0.0	0.0

Trave	v.Omeg	V N/M	V stab	V[7.5.4]	M Ed	V[7.5.5]	N Ed	V[7.5.6]	V Ed,G	V Ed,M
					0.0		0.0		0.0	0.0
					0.0	0.0	0.0	0.0	0.0	0.0

Pilas.	Stato	Note	V V/T	V N/M	V stab	Cl.LamS	22LamS	33	Snell.	Chi mn	V flstLamS	LT	Chi LT	Rif. cmb
1	ok	s=2,m=11	4.43e-03	0.08	0.05	2	0.9	0.9	83.7	0.74				25,29,29,0

2	ok s=2,m=114.41e-03	0.08	0.05	2	0.9	0.9	83.7	0.74	34,22,22,0
3	ok s=2,m=114.41e-03	0.08	0.05	2	0.9	0.9	83.7	0.74	28,24,24,0
4	ok s=2,m=114.43e-03	0.08	0.05	2	0.9	0.9	83.7	0.74	19,31,31,0

Pilas.	V V/T	V N/M	V stab	LamS 22	LamS 33	Snell.	Chi mn	V flst	LamS LT	Chi LT
	4.43e-03	0.08	0.05	0.89	0.89	83.72	0.74			

Pilas.	f.Om. N	f.Om. T	Stato	V V/T	V N/M	V stab	V flst	Rif. cmbV[7.5.10]	V Ed sovr.	Xi sovr.	Xf sovr.	Yi sovr.	Yf
									daN				
1	0.0	0.0	ok	0.0	0.0			0,0,0,0					
2	0.0	0.0	ok	0.0	0.0			0,0,0,0					
3	0.0	0.0	ok	0.0	0.0			0,0,0,0					
4	0.0	0.0	ok	0.0	0.0			0,0,0,0					

Pilas.	V V/T	V N/M	V stab	V flst	V[7.5.10]	V Ed sovr.	Xi sovr.	Xf sovr.	Yi sovr.	Yf
	0.0	0.0								

STATI LIMITE D' ESERCIZIO ACCIAIO

LEGENDA TABELLA STATI LIMITE D' ESERCIZIO ACCIAIO

In tabella vengono riportati i valori di interesse per il controllo degli stati limite d'esercizio.

In particolare vengono riportati, per gli elementi trave, i risultati relativi alle combinazioni considerate (rare o caratteristiche).

I valori di interesse sono i seguenti:

f*1000/L	massima deformazione normalizzata in combinazioni rare
-----------------	--

Si precisa che i valori di massima deformazione per travi sono riferiti ai due piani locali (1-2 con momenti flettenti 3-3 e 1-3 con momenti flettenti 2-2). Il valore riportato (massimo) è espresso in 1000/L per rendere agevole il confronto di più valori e in particolare di più range di valori (ad esempio 2 rappresenta L/500, 4 L/250 e così via).

Trave	f*1000/L	Trave	f*1000/L	Trave	f*1000/L	Trave	f*1000/L	Trave	f*1000/L	Trave	f*1000/L	Trave	f*1000/L
5	0.3	6	8.06e-03	7	8.06e-03	8	0.3						

VERIFICHE ELEMENTI PARETE E/O GUSCIO IN C.A.

LEGENDA TABELLA VERIFICHE ELEMENTI PARETE E GUSCIO IN C.A.

Per le pareti in c.a., in ottemperanza al cap. 7 del DM 17-01-18, viene effettuata una doppia progettazione: sia come *Singolo Elemento* sia come *Parete Sismica* o *Parete Debolmente Armata*.

Per la progettazione come *Singolo Elemento* di ogni elemento vengono riportati il codice dello stato di verifica con le sigle **Ok e NV**, il rapporto x/d , la verifica per sollecitazioni ultime (verifica a compressione media gli sforzi membranali, verifica a presso-flessionale e verifica a sollecitazioni taglianti), gli sforzi membranali e flessionali, il quantitativo di armatura nella direzione principale e secondaria sia inferiore che superiore e il quantitativo di armatura a taglio.

Per la progettazione come *Parete Sismica* o *Parete Debolmente Armata* vengono riportate invece le caratteristiche geometriche della parete e delle zone dissipative (quest'ultime solo nel caso di parete sismica), i coefficienti di verifica a compressione assiale, pressoflessione e sollecitazioni taglianti.

Inoltre vengono riportate per ogni quota significativa l'armatura principale e secondaria, l'armatura in zona confinata (solo per parete sismica) e non confinata, l'armatura concentrata all'estremità (per pareti debolmente armate), lo sforzo assiale aggiuntivo per q superiore a 2 e i valori di involuppo di taglio e momento. Per le pareti debolmente armate viene riportato anche lo stato di verifica relativo alla snellezza.

Le azioni derivate dall'analisi, in ogni combinazione di calcolo, sono elaborate come previsto al punto 7.4.4.5.1: traslazione del momento, incremento e variazione diagramma taglio, incremento e decremento sforzo assiale

La progettazione nel caso dei gusci viene effettuata una progettazione come *Singolo Elemento*, riportando in tabella il rapporto x/d , la verifica per sollecitazioni ultime, (verifica a compressione media gli sforzi membranali, verifica a presso-flessionale e verifica a sollecitazioni taglianti) di ogni elemento.

Per ogni elemento, viene riportata inoltre la maglia di armatura necessaria in relazione alle risultanze della progettazione dei nodi dell'elemento stesso. Le quantità di armature necessarie sono armature (disposte rispettivamente in direzione principale e secondaria, inferiore e superiore) distribuite nell'elemento ed espresse in centimetri quadri per sviluppo lineare pari ad un metro.

Nel caso dei gusci viene effettuata, inoltre, la verifica a punzonamento, riportando in tabella il codice dello stato di verifica, il coefficiente di verifica per piastre prive di armature a taglio lungo il perimetro resistente e lungo il perimetro del pilastro, coefficiente di incremento dovuto ai momenti flettenti, fattore di amplificazione per le fondazioni, il fattore di amplificazione dell'altezza utile per individuare il perimetro di verifica lungo il quale l'armatura a taglio non è richiesta, il quantitativo di armatura a punzonamento, il numero di serie di armature, il numero di braccia di armatura ed il riferimento alla combinazione più gravosa.

Simbologia adottata nelle tabelle di verifica

Per gli elementi con progettazione di tipo "*Singolo Elemento ...*" è presente una tabella con i simboli di seguito descritti:

Macro Guscio	Numero del macroelemento di tipo guscio (elementi non verticali contigui ed analoghi per proprietà)
Macro Setto	Numero del macroelemento di tipo setto (elementi verticali contigui ed analoghi per proprietà)
Spessore	Spessore della parete
Id Materiale	Codice del materiale assegnato all'elemento
Id Criterio	Codice del criterio di progetto assegnato all'elemento
Progettazione	Sigla tipo di Elemento: - Singolo Elemento; - Singolo Elemento FONDAZIONE; - Singolo Elemento NON DISSIPATIVO

Per gli elementi con progettazione di tipo “*Parete Sismica*” e “*Parete Debolmente Armata*” è presente una tabella con i simboli di seguito descritti:

Parete	Numero della PARETE SISMICA
Parete PDA	Numero della PARETE DEBOLMENTE ARMATA
H totale	Altezza complessiva della parete
Spessore	Spessore della parete
H critica	Altezza come da punto 7.4.4.5.1 per traslazione momento (solo in Parete Sismica)
H critica V	Altezza della zona dissipativa (solo in Parete Sismica)
L totale	Larghezza di base della parete
L confinata	Lunghezza della zona dissipativa (solo in Parete Sismica)
Verif. N	Verifica di cui al punto 7.4.4.5.1 compressione semplice
Verif. N-M	Verifica di cui al punto 7.4.4.5.1 pressoflessione
Fattore V	Fattore di amplificazione del taglio di cui al punto 7.4.4.5.1
Diagramma V	Diagramma elaborato per effetto modi superiori come da fig. 7.4.4
Verif. V	Verifica di cui al punto 7.4.4.5.1 taglio (compressione cls, trazione acciaio, scorrimento in zona critica) (solo in Parete Sismica)
Verifica Snellezza	Verifica di cui al punto 7.4.4.5.1 limitazione compressione per prevenire l'instabilità (solo in Parete Debolmente Armata)
Prog. composta	Sigla per la progettazione composta

Sia per le verifiche degli elementi con progettazione di tipo “*Singolo Elemento ...*” e “*Parete ...*” è presente una tabella con i simboli di seguito descritti:

Nodo	numero del nodo
Stato	codice di verifica dell'elemento ok o NV
x/d	rapporto tra posizione dell'asse neutro e altezza utile alla rottura della sezione (per sola flessione)
V N/M	Verifica delle sollecitazioni Normali (momento e sforzo normale)
Ver. rid	Rapporto Nd/Nu (Nu ottenuto con riduzione del 25% di fcd)
Af pr+	quantità di armatura richiesta in direzione principale relativa alla faccia positiva (estradosso piastre) (valore derivante da calcolo o minimo normativo)
Af pr-	quantità di armatura richiesta in direzione principale relativa alla faccia negativa (intradosso piastre) (valore derivante da calcolo o minimo normativo)
Af sec+	quantità di armatura richiesta in direzione secondaria relativa alla faccia positiva (estradosso piastre) (valore derivante da calcolo o minimo normativo)

Af sec-	quantità di armatura richiesta in direzione secondaria relativa alla faccia negativa (intradosso piastre) (valore derivante da calcolo o minimo normativo)
Nz No Nzo	Sforzi membranali per pareti e\o setti verticali
Mz Mo Mzo	Sforzi flessionali per pareti e\o setti verticali
Nx Ny Nxy	Sforzi membranali per gusci orizzontali
Mx Mx Mxy	Sforzi flessionali per gusci orizzontali

Nodo	numero del nodo
Stato	codice di verifica dell'elemento ok o NV
Max tau	Tensione tangenziale Massima
Ver V pr	Verifica a taglio nella direzione principale lato calcestruzzo
Ver V sec	Verifica a taglio nella direzione secondaria lato calcestruzzo
Af V pr	Armatura nella direzione principale
V pr-	Verifica dell'armatura nella direzione principale
Af V sec	Armatura nella direzione secondaria
V sec-	Verifica dell'armatura nella direzione secondaria

Per le verifiche degli elementi con progettazione "*Parete Sismica o Parete Debolmente Armata*", oltre alla tabella con le verifiche per gli elementi con progettazione "*Singolo Elemento ...*", è presente una tabella con i simboli di seguito descritti:

Quota	Ascissa verticale di riferimento
Af conf.	Numero e diametro armatura presente in una zona confinata
Af std	Diametro e passo armatura in zona non confinata (doppia maglia)
Af estremi	Diametro dei ferri di estremità del pannello; se posto uguale 0, viene utilizzato il diametro standard
Af V (ori)	Diametro e passo armatura orizzontale (doppia maglia)
Ver. N	Rapporto tra azione di calcolo e resistenza a compressione (normalizzato a 1 in quanto da confrontare con 40% in CDB e 35 % in CDA)
Ver. N/M	Rapporto tra azione di calcolo e resistenza a pressoflessione
Ver. V acc(7)	Rapporto tra azione di calcolo e resistenza a taglio-trazione per alfaS minore di 2 secondo paragrafo 7.4.4.5.1
Ver. V cls	Rapporto tra azione di calcolo e resistenza a taglio-compressione
Ver. V acc	Rapporto tra azione di calcolo e resistenza a taglio-trazione
Ver. V scorr.	Rapporto tra azione di calcolo e resistenza a taglio scorrimento
N add	Sforzo assiale di cui al punto 7.4.4.5.1 da sommare e sottrarre nelle verifiche quando q supera 2
N invil M invil	Inviluppo del Momento e Sforzo Normale come al punto 7.4.4.5.1 (informativo) (solo in Parete Sismica)

Quota	Ascissa verticale di riferimento
N v.N	Valore dello sforzo assiale per cui Ver. N attinge il massimo valore
N v.M/N, M v.M/N	Valore dello sforzo assiale e momento per cui Ver. N/M attinge il massimo valore

N v.M/N, M v.M/N Mo v.M/N	Valore dello sforzo assiale e dei momenti per cui Ver. N/M attinge il massimo valore (per le pareti estese debolmente armate)
N v.Vcls, V v.Vcls,	Valore dello sforzo assiale e taglio per cui Ver. V. cls attinge il massimo valore
N v.Vacc, M v.Vacc, V v.Vacc,	Valore dello sforzo assiale, momento e taglio per cui Ver. V. acc attinge il massimo valore
N v.Vscorr, M v.Vscorr, V v.Vscorr,	Valore dello sforzo assiale, momento e taglio per cui Ver. V. scorr.e attinge il massimo valore
N v.N	Valore dello sforzo assiale per cui Ver. N attinge il massimo valore
N v.M/N, M v.M/N	Valore dello sforzo assiale e momento per cui Ver. N/M attinge il massimo valore
N v.M/N, M v.M/N Mo v.M/N	Valore dello sforzo assiale e dei momenti per cui Ver. N/M attinge il massimo valore (per le pareti estese debolmente armate)
N v.Vcls, V v.Vcls,	Valore dello sforzo assiale e taglio per cui Ver. V. cls attinge il massimo valore

Quota	Ascissa verticale di riferimento
CtgT Vcls	Valore di ctg(teta) adottato nella verifica V compressione cls
Vrsd Vcls	Valore della resistenza a taglio trazione (armatura di calcolo)
Vrcd Vcls	Valore della resistenza a taglio compressione
CtgT Vacc	Valore di ctg(teta) adottato nella verifica V trazione armatura
Vrsd Vacc	Valore della resistenza a taglio trazione (armatura presente)
Vrcd Vacc	Valore della resistenza a taglio compressione
Vdd	Valore del contributo alla resistenza allo scorrimento come da [7.4.20]
Vid	Valore del contributo alla resistenza allo scorrimento come da [7.4.21]
A s.i.	Somma delle aree di armature
Incli.	Angolo di inclinazione delle armature
Dist.	Distanza alla base tra le armature inclinate

Quota	Ascissa verticale di riferimento
V[7.4.16]	Verifica a taglio-trazione dell'armatura dell'anima (7.4.16)
N M V	Sollecitazioni di calcolo della condizione più gravosa
Alfas	Rapporto di Taglio
Vrd,c	Resistenza a taglio degli elementi non armati
VRd,s	Resistenza a taglio nei confronti dello scorrimento
V[7.4.17]	Verifica a taglio-trazione dell'armatura dell'anima (7.4.17)
roH	Rapporto tra l'armatura orizzontale e l'area della sezione relativa di calcestruzzo
roV	Rapporto tra l'armatura verticale e l'area della sezione relativa di calcestruzzo
roN	Sforzo normale adimensionalizzato Ned/(bw fyd)

Per la verifica a *Punzonamento* è presente una tabella con i simboli di seguito descritti:

Nodo	numero del nodo
Stato	codice di verifica dell'elemento ok o NV
V. 6.47	Fattore di sicurezza per la verifica per piastre prive di armature a taglio lungo il perimetro resistente U1

V. 6.53	Fattore di sicurezza per la verifica per piastre prive di armature a taglio lungo il perimetro del pilastro U0
Beta	Fattore di incremento dovuto ai momenti flettenti
f. a fon	fattore di amplificazione per le fondazioni (solo per gusci di fondazione)
f. Uout	fattore di amplificazione dell'altezza utile per individuare il perimetro di verifica lungo il quale l'armatura a taglio non è richiesta
Aw tot	Quantitativo di armatura per la verifica di piastre munite di armatura (formula 6.52 dell'EC2)
Asw,min	Quantitativo minimo di armatura previsto dai dettagli costruttivi (formula 9.11 dell'EC2)
n. x serie	Numero di serie di armature
n.ser 0(R)	Numero di braccia delle armature in direzione 0 (o numero di braccia radiale)
n.ser 90	Numero di braccia delle armature in direzione 90 (solo se armatura cruciforme)
Rif. cmb	Riferimento combinazioni da cui si generano le verifiche più gravose

PROGETTAZIONE DELLE FONDAZIONI

Il D.M.17/01/2018 - par: 7.2.5 prevede:

“Sia per CD“A” sia per CD“B” il dimensionamento delle strutture di fondazione e la verifica di sicurezza del complesso fondazione-terreno devono essere eseguiti assumendo come azione in fondazione, trasmessa dagli elementi soprastanti, una tra le seguenti:

- quella derivante dall'analisi strutturale eseguita ipotizzando comportamento strutturale non dissipativo;
- [...];
- quella trasferita dagli elementi soprastanti nell'ipotesi di comportamento strutturale dissipativo, amplificata di un coefficiente pari a 1,30 in CD“A” e 1,10 in CD“B”;

Nel contesto visualizzazione risultati e nella stampa della relazione sulle fondazioni PRO_SAP mostra le sollecitazioni che derivano dall'analisi non incrementate sia in termini di pressioni sul terreno che in termini di sollecitazioni.

La progettazione degli elementi strutturali con proprietà fondazione è effettuata da PRO_SAP (per travi e platee) o da PRO_CAD Plinti (per plinti e pali di fondazione) incrementando la componente sismica delle combinazioni di un coefficiente pari 1.1 in CDB e 1.3 in CDA per pali, plinti, travi e platee.

Per i bicchieri dei plinti di fondazione prefabbricati l'incremento delle sollecitazioni ha un fattore pari a 1.2 in CDB e 1.35 in CDA.

N.B.: nel caso di comportamento strutturale non dissipativo la progettazione viene effettuata senza nessun incremento.

Le verifiche geotecniche di pali, plinti, plinti su pali, travi e platee vengono effettuate dal modulo geotecnico incrementando automaticamente la componente sismica delle azioni di un fattore 1.1 in CDB e 1.3 in CDA.

N.B.: nel caso di comportamento strutturale non dissipativo le verifiche geotecniche vengono effettuate senza nessun incremento.

Macro Guscio	Spessore	Id Materiale	Id Criterio	Progettazione
	cm			

Macro Guscio	Spessore	Id Materiale	Id Criterio	Progettazione
1	25.00	1	2	Singolo elemento

Nodo	Stato	x/d	V N/M	ver. rid	Af pr-	Af pr+	Af sec-	Af sec+	N x	N y	N xy	M x	M y	M xy
									daN/cm	daN/cm	daN/cm	daN	daN	daN
1	ok	0.19	2.17e-02	1.51e-04	5.7	5.7	5.7	5.7	0.2	0.2	-0.3	-76.9	-65.3	-1.9
2	ok	0.19	1.94e-02	1.11e-04	5.7	5.7	5.7	5.7	0.2	-0.2	0.3	-43.8	-40.7	23.9
3	ok	0.19	1.94e-02	1.11e-04	5.7	5.7	5.7	5.7	0.2	-0.2	-0.3	-43.8	-40.7	-23.9
4	ok	0.19	2.17e-02	1.51e-04	5.7	5.7	5.7	5.7	0.2	-0.2	0.5	-50.0	-48.1	18.8
5	ok	0.19	3.30e-02	2.00e-04	5.7	5.7	5.7	5.7	1.1	0.1	-0.2	-77.0	-72.1	-33.6
6	ok	0.19	3.30e-02	2.00e-04	5.7	5.7	5.7	5.7	1.1	-1.41e-02	0.1	-91.8	-52.6	34.3
7	ok	0.19	2.94e-02	1.61e-04	5.7	5.7	5.7	5.7	0.6	0.4	0.2	-50.1	-57.1	56.3
8	ok	0.19	2.94e-02	1.61e-04	5.7	5.7	5.7	5.7	0.2	-1.11e-02	-0.1	-83.7	-28.1	-26.0
9	ok	0.19	3.33e-02	2.75e-04	5.7	5.7	5.7	5.7	0.2	0.9	-0.1	-79.4	-85.0	-23.2
10	ok	0.19	3.30e-02	2.82e-04	5.7	5.7	5.7	5.7	0.2	-0.1	0.4	-52.5	-126.3	-5.9
11	ok	0.19	3.33e-02	2.75e-04	5.7	5.7	5.7	5.7	0.4	0.6	0.4	-97.6	-85.0	33.0
12	ok	0.19	3.30e-02	2.82e-04	5.7	5.7	5.7	5.7	0.3	-0.2	-0.5	-45.2	-118.6	-6.4
13	ok	0.19	6.47e-02	1.29e-03	5.7	5.7	5.7	5.7	-1.8	-1.7	2.5	-167.2	-205.6	97.4
14	ok	0.19	6.47e-02	1.29e-03	5.7	5.7	5.7	5.7	-1.8	-1.7	-2.5	-167.2	-205.6	-97.4
15	ok	0.19	3.67e-02	2.71e-04	5.7	5.7	5.7	5.7	0.4	-0.7	-0.5	-90.0	-110.9	-45.3
16	ok	0.19	3.67e-02	2.71e-04	5.7	5.7	5.7	5.7	0.4	-0.7	0.5	-90.0	-110.9	45.3
17	ok	0.19	6.10e-02	7.81e-04	5.7	5.7	5.7	5.7	-1.1	0.2	-1.7	-279.6	-160.6	-39.2
18	ok	0.19	6.10e-02	7.81e-04	5.7	5.7	5.7	5.7	-1.1	0.2	1.7	-279.6	-160.6	39.2
19	ok	0.19	4.41e-02	2.52e-04	5.7	5.7	5.7	5.7	0.3	-0.3	-0.2	-182.7	-66.8	7.2
20	ok	0.19	4.41e-02	2.52e-04	5.7	5.7	5.7	5.7	0.3	-0.3	0.2	-182.7	-66.8	-7.2
21	ok	0.19	3.88e-02	5.72e-05	5.7	5.7	5.7	5.7	0.4	0.1	0.1	-159.5	-26.1	-11.1
22	ok	0.19	3.88e-02	5.72e-05	5.7	5.7	5.7	5.7	0.4	0.1	-0.1	-159.5	-26.1	11.1
23	ok	0.19	5.01e-02	1.37e-04	5.7	5.7	5.7	5.7	0.8	-6.81e-02	-0.6	-214.9	-40.2	-4.6
24	ok	0.19	5.01e-02	1.37e-04	5.7	5.7	5.7	5.7	0.8	-6.81e-02	0.6	-214.9	-40.2	4.6
25	ok	0.19	2.94e-02	8.82e-05	5.7	5.7	5.7	5.7	0.3	1.61e-02	5.84e-02	-99.5	-35.0	28.5
26	ok	0.19	2.94e-02	8.82e-05	5.7	5.7	5.7	5.7	0.3	1.61e-02	-5.84e-02	-99.5	-35.0	-28.5
27	ok	0.19	1.58e-02	3.90e-05	5.7	5.7	5.7	5.7	1.2	-8.39e-02	-0.1	-15.8	-15.7	-28.1
28	ok	0.19	1.58e-02	3.90e-05	5.7	5.7	5.7	5.7	1.3	0.1	-0.2	-15.4	-21.5	14.9
29	ok	0.19	1.83e-02	2.30e-04	5.7	5.7	5.7	5.7	1.7	0.4	1.4	31.9	38.9	10.2
30	ok	0.19	1.83e-02	2.30e-04	5.7	5.7	5.7	5.7	1.3	-9.41e-02	-0.6	28.9	35.8	-4.0
31	ok	0.19	3.00e-02	8.15e-05	5.7	5.7	5.7	5.7	0.9	-8.02e-02	-0.3	-65.9	-79.8	-37.3
32	ok	0.19	3.00e-02	8.15e-05	5.7	5.7	5.7	5.7	0.9	-8.02e-02	0.3	-65.9	-79.8	37.3
33	ok	0.19	1.11e-02	0.0	5.7	5.7	5.7	5.7	0.2	0.7	0.1	-37.8	-32.5	-0.3
34	ok	0.19	2.23e-02	0.0	5.7	5.7	5.7	5.7	3.79e-02	0.9	-0.1	-55.8	-69.4	-7.0
35	ok	0.19	1.55e-02	1.50e-04	5.7	5.7	5.7	5.7	0.5	1.2	0.6	-53.6	-33.9	9.5
36	ok	0.19	1.40e-02	0.0	5.7	5.7	5.7	5.7	0.4	1.1	0.2	-54.0	-18.1	-1.5
37	ok	0.19	2.35e-02	0.0	5.7	5.7	5.7	5.7	2.8	2.4	-0.2	-61.4	-74.5	-2.8
38	ok	0.19	4.79e-02	1.30e-04	5.7	5.7	5.7	5.7	0.1	1.2	0.5	-209.1	-62.7	1.11e-02
39	ok	0.19	4.62e-02	3.70e-05	5.7	5.7	5.7	5.7	0.2	1.0	0.2	-197.4	-62.1	1.7
40	ok	0.19	1.45e-02	0.0	5.7	5.7	5.7	5.7	1.8	1.8	-0.2	-35.4	-47.0	-1.3
41	ok	0.19	9.80e-02	2.34e-04	5.7	5.7	5.7	5.7	0.4	-0.2	0.1	-122.7	-350.5	81.9
42	ok	0.19	9.80e-02	2.34e-04	5.7	5.7	5.7	5.7	0.4	-0.2	-0.1	-122.7	-350.5	-81.9
43	ok	0.19	9.52e-02	1.75e-04	5.7	5.7	5.7	5.7	3.53e-02	-0.2	-0.1	-109.4	-344.6	-74.9
44	ok	0.19	9.52e-02	1.75e-04	5.7	5.7	5.7	5.7	3.53e-02	-0.2	0.1	-109.4	-344.6	74.9
45	ok	0.19	8.54e-02	2.64e-04	5.7	5.7	5.7	5.7	-0.3	0.4	0.2	-305.6	-100.8	73.3
46	ok	0.19	8.56e-02	2.13e-04	5.7	5.7	5.7	5.7	0.1	0.2	-7.84e-02	-125.1	-70.3	-151.5
47	ok	0.19	8.54e-02	2.64e-04	5.7	5.7	5.7	5.7	-0.3	-0.3	-5.07e-02	-307.7	-106.4	-33.8

48	ok	0.19	8.56e-02	2.13e-04	5.7	5.7	5.7	5.7	-3.10e-02	-0.4	4.82e-03	-71.3	-0.9	-157.8
49	ok	0.19	0.1	2.18e-04	5.7	5.7	5.7	5.7	0.2	2.86e-03	7.04e-02	-378.6	-80.3	56.8
50	ok	0.19	0.1	4.60e-04	5.7	5.7	5.7	5.7	0.5	-1.7	6.01e-03	-134.0	-138.8	197.0
51	ok	0.19	3.30e-02	8.31e-05	5.7	5.7	5.7	5.7	0.6	4.00e-02	0.1	-107.1	-51.5	-30.1
52	ok	0.19	3.71e-02	1.13e-04	5.7	5.7	5.7	5.7	0.2	0.3	0.5	-152.8	-39.3	-9.8
53	ok	0.19	5.34e-02	2.97e-04	5.7	5.7	5.7	5.7	0.3	-2.57e-02	-1.0	-236.5	-87.1	-10.7
54	ok	0.19	1.41e-02	6.25e-05	5.7	5.7	5.7	5.7	1.8	0.3	0.7	20.5	-17.6	11.9
55	ok	0.19	0.2	1.74e-04	5.7	5.7	5.7	5.7	-0.1	-0.5	-0.3	-258.1	-454.7	213.0
56	ok	0.19	1.98e-02	0.0	5.7	5.7	5.7	5.7	7.99e-02	1.0	-2.74e-02	-72.2	-49.9	-7.3
57	ok	0.19	0.1	5.34e-04	5.7	5.7	5.7	5.7	-0.6	-0.6	-4.12e-03	-121.0	-428.7	-79.2
58	ok	0.19	0.1	5.34e-04	5.7	5.7	5.7	5.7	-0.6	-0.6	4.12e-03	-121.0	-428.7	79.2
59	ok	0.19	0.2	1.74e-04	5.7	5.7	5.7	5.7	-0.1	-0.5	0.3	-258.1	-454.7	-213.0
60	ok	0.19	0.1	4.60e-04	5.7	5.7	5.7	5.7	0.4	0.1	-9.93e-02	-378.5	-141.0	-81.9
61	ok	0.19	0.1	2.18e-04	5.7	5.7	5.7	5.7	0.2	-0.5	-0.1	-360.2	-100.8	89.2
62	ok	0.19	3.30e-02	8.31e-05	5.7	5.7	5.7	5.7	0.6	4.00e-02	-0.1	-107.1	-51.5	30.1
63	ok	0.19	3.71e-02	1.13e-04	5.7	5.7	5.7	5.7	0.2	0.3	-0.5	-152.8	-39.3	9.8
64	ok	0.19	5.34e-02	2.97e-04	5.7	5.7	5.7	5.7	0.3	-2.57e-02	1.0	-236.5	-87.1	10.7
65	ok	0.19	1.41e-02	6.25e-05	5.7	5.7	5.7	5.7	1.4	6.92e-02	-0.4	5.8	-25.9	-22.2
66	ok	0.19	0.2	4.31e-04	5.7	5.7	5.7	5.7	-0.4	-0.5	0.6	-280.1	-477.6	-217.1
67	ok	0.19	1.28e-02	0.0	5.7	5.7	5.7	5.7	0.3	0.8	0.1	-45.6	-23.7	-2.1
68	ok	0.19	0.1	6.30e-04	5.7	5.7	5.7	5.7	-1.9	0.5	-0.1	-158.8	-438.5	92.5
69	ok	0.19	0.2	4.31e-04	5.7	5.7	5.7	5.7	-0.4	-0.5	-0.6	-280.1	-477.6	217.1
70	ok	0.19	0.1	6.30e-04	5.7	5.7	5.7	5.7	-1.9	0.5	0.1	-158.8	-438.5	-92.5
81	ok	0.19	3.03e-02	1.74e-04	5.7	5.7	5.7	5.7	-0.4	0.5	0.1	-48.5	-101.3	28.3
82	ok	0.19	3.84e-02	2.17e-04	5.7	5.7	5.7	5.7	-0.4	0.3	-0.6	-48.9	-138.5	-24.0
83	ok	0.19	3.03e-02	1.74e-04	5.7	5.7	5.7	5.7	-0.1	0.3	0.2	-36.5	-105.0	-18.5
84	ok	0.19	3.84e-02	2.17e-04	5.7	5.7	5.7	5.7	-0.4	0.3	0.6	-48.9	-138.5	24.0
85	ok	0.19	5.13e-02	5.04e-04	5.7	5.7	5.7	5.7	-0.9	0.2	1.0	-89.3	-191.3	29.9
86	ok	0.19	3.32e-02	4.31e-04	5.7	5.7	5.7	5.7	-1.1	1.3	0.8	-128.0	-53.5	2.9
87	ok	0.19	4.07e-02	4.05e-04	5.7	5.7	5.7	5.7	-0.9	1.0	0.2	-84.8	-84.8	-32.7
88	ok	0.19	5.87e-02	1.42e-03	5.7	5.7	5.7	5.7	-0.9	-1.3	2.8	-188.4	-191.7	70.1
89	ok	0.19	1.91e-02	1.92e-04	5.7	5.7	5.7	5.7	2.0	0.3	1.5	-24.3	-67.9	17.7
90	ok	0.19	4.82e-02	6.40e-04	5.7	5.7	5.7	5.7	-0.3	-0.3	-1.4	-212.7	-159.5	-5.1
91	ok	0.19	4.92e-02	3.97e-04	5.7	5.7	5.7	5.7	-1.2	2.2	0.3	-218.9	-56.4	24.0
92	ok	0.19	1.16e-02	0.0	5.7	5.7	5.7	5.7	2.1	1.0	0.4	-15.5	-34.8	13.1
93	ok	0.19	5.13e-02	5.04e-04	5.7	5.7	5.7	5.7	-0.9	0.2	-1.0	-89.3	-191.3	-29.9
94	ok	0.19	3.32e-02	4.31e-04	5.7	5.7	5.7	5.7	-7.44e-02	1.0	-0.5	-115.4	-45.3	12.3
95	ok	0.19	4.07e-02	4.05e-04	5.7	5.7	5.7	5.7	-0.7	0.9	-0.4	-83.2	-132.7	30.0
96	ok	0.19	5.87e-02	1.42e-03	5.7	5.7	5.7	5.7	-0.9	-1.3	-2.8	-188.4	-191.7	-70.1
97	ok	0.19	1.91e-02	1.92e-04	5.7	5.7	5.7	5.7	2.0	0.3	-1.5	-24.3	-67.9	-17.7
98	ok	0.19	4.82e-02	6.40e-04	5.7	5.7	5.7	5.7	-0.3	-0.3	1.4	-212.7	-159.5	5.1
99	ok	0.19	4.92e-02	3.97e-04	5.7	5.7	5.7	5.7	-1.2	2.2	-0.3	-218.9	-56.4	-24.0
100	ok	0.19	1.16e-02	0.0	5.7	5.7	5.7	5.7	2.1	1.0	-0.4	-15.5	-34.8	-13.1
143	ok	0.19	1.05e-02	6.88e-05	5.7	5.7	5.7	5.7	0.2	-0.3	4.17e-02	-34.4	-15.9	10.7
144	ok	0.19	1.12e-02	8.32e-05	5.7	5.7	5.7	5.7	0.3	-0.2	6.00e-03	-25.0	-15.4	-3.8
145	ok	0.19	2.17e-02	1.47e-05	5.7	5.7	5.7	5.7	0.9	6.79e-02	-9.99e-03	-75.1	6.0	16.1
146	ok	0.19	1.98e-02	6.00e-05	5.7	5.7	5.7	5.7	-3.38e-02	0.1	6.33e-02	-64.8	-3.7	-11.9
147	ok	0.19	4.01e-02	3.38e-05	5.7	5.7	5.7	5.7	0.4	-2.01e-02	-1.48e-02	-162.1	-0.2	-9.7
148	ok	0.19	4.77e-02	1.87e-05	5.7	5.7	5.7	5.7	1.3	-7.19e-03	-2.15e-02	-195.3	2.8	5.4
149	ok	0.19	2.41e-02	5.80e-05	5.7	5.7	5.7	5.7	4.84e-02	3.77e-03	3.71e-02	-89.9	-4.1	-11.8
150	ok	0.19	1.23e-02	2.42e-05	5.7	5.7	5.7	5.7	1.0	-2.58e-02	-3.97e-02	-24.6	-3.8	-2.3
151	ok	0.19	2.01e-02	4.88e-05	5.7	5.7	5.7	5.7	0.3	1.20e-02	9.04e-02	-16.2	43.8	-1.7
152	ok	0.19	1.82e-02	6.90e-05	5.7	5.7	5.7	5.7	0.4	-8.77e-02	4.13e-02	-51.0	-47.1	12.5
153	ok	0.19	1.12e-02	8.32e-05	5.7	5.7	5.7	5.7	0.4	-0.3	2.88e-02	-36.2	-14.5	10.3
154	ok	0.19	1.05e-02	6.88e-05	5.7	5.7	5.7	5.7	0.2	-0.3	-4.17e-02	-34.4	-15.9	-10.7
155	ok	0.19	2.17e-02	1.47e-05	5.7	5.7	5.7	5.7	0.9	6.79e-02	9.99e-03	-75.1	6.0	-16.1

156	ok	0.19	1.98e-02	6.00e-05	5.7	5.7	5.7	5.7	0.2	0.1	-0.2	-73.8	-15.0	1.1
157	ok	0.19	4.01e-02	3.38e-05	5.7	5.7	5.7	5.7	0.4	-2.01e-02	1.48e-02	-162.1	-0.2	9.7
158	ok	0.19	4.77e-02	1.87e-05	5.7	5.7	5.7	5.7	1.3	-7.19e-03	2.15e-02	-195.3	2.8	-5.4
159	ok	0.19	2.41e-02	5.80e-05	5.7	5.7	5.7	5.7	0.5	-1.35e-02	-5.93e-02	-74.7	-9.8	22.9
160	ok	0.19	1.23e-02	2.42e-05	5.7	5.7	5.7	5.7	1.0	-3.74e-02	0.2	-19.8	-11.4	-12.6
161	ok	0.19	2.01e-02	4.88e-05	5.7	5.7	5.7	5.7	0.4	-0.1	0.2	-64.8	-46.7	-9.6
162	ok	0.19	1.82e-02	6.90e-05	5.7	5.7	5.7	5.7	0.2	-0.1	-0.2	-63.7	-50.7	7.4
163	ok	0.19	1.22e-02	6.87e-05	5.7	5.7	5.7	5.7	-3.24e-02	0.2	2.06e-02	-6.4	-43.9	-5.0
164	ok	0.19	2.79e-02	2.35e-06	5.7	5.7	5.7	5.7	6.72e-02	0.8	-1.96e-02	-3.5	-98.2	-10.4
165	ok	0.19	2.79e-02	2.35e-06	5.7	5.7	5.7	5.7	7.65e-02	0.7	-7.20e-02	2.5	-95.5	6.0
166	ok	0.19	2.15e-02	5.41e-05	5.7	5.7	5.7	5.7	-0.2	0.4	0.2	-38.0	-66.7	-6.2
167	ok	0.19	2.15e-02	5.41e-05	5.7	5.7	5.7	5.7	-6.46e-02	0.8	-0.1	-35.7	-57.6	-10.2
168	ok	0.19	7.92e-03	3.48e-05	5.7	5.7	5.7	5.7	3.49e-02	-1.10e-03	-1.17e-02	-4.4	9.9	1.5
169	ok	0.19	2.06e-02	1.54e-05	5.7	5.7	5.7	5.7	1.97e-02	0.6	-3.94e-02	-3.8	-72.1	9.4
170	ok	0.19	7.92e-03	3.48e-05	5.7	5.7	5.7	5.7	-7.20e-02	-7.62e-02	-3.06e-02	-6.7	-19.4	16.5
171	ok	0.19	2.06e-02	1.54e-05	5.7	5.7	5.7	5.7	2.97e-02	0.9	4.65e-02	-8.6	-64.6	-14.2
172	ok	0.19	1.13e-02	7.59e-05	5.7	5.7	5.7	5.7	-0.2	0.1	-0.1	15.4	-30.1	-5.5
173	ok	0.19	1.13e-02	7.59e-05	5.7	5.7	5.7	5.7	-0.3	0.1	0.1	5.2	-31.5	7.9
174	ok	0.19	2.62e-02	8.90e-05	5.7	5.7	5.7	5.7	0.2	0.5	-5.31e-02	-19.3	-95.5	-4.5
175	ok	0.19	2.62e-02	8.90e-05	5.7	5.7	5.7	5.7	0.2	0.5	7.21e-02	-9.4	-83.1	-4.9
176	ok	0.19	2.49e-02	3.41e-05	5.7	5.7	5.7	5.7	-5.12e-02	0.8	-5.78e-02	-7.0	-88.3	0.3
177	ok	0.19	8.28e-03	2.89e-05	5.7	5.7	5.7	5.7	-3.67e-02	-4.89e-02	8.32e-04	-1.8	9.6	0.7
178	ok	0.19	8.28e-03	2.89e-05	5.7	5.7	5.7	5.7	-7.24e-02	-6.45e-02	2.85e-02	-9.9	-20.2	-16.1
179	ok	0.19	2.16e-02	3.19e-05	5.7	5.7	5.7	5.7	-5.43e-02	0.6	-2.68e-02	-39.4	-57.9	-12.4
180	ok	0.19	2.16e-02	3.19e-05	5.7	5.7	5.7	5.7	-2.50e-02	0.4	0.1	-10.0	-50.3	3.9
181	ok	0.19	1.15e-02	7.67e-05	5.7	5.7	5.7	5.7	-0.3	0.4	1.38e-02	-11.2	-37.8	9.7
182	ok	0.19	1.15e-02	7.67e-05	5.7	5.7	5.7	5.7	-0.2	0.3	-4.02e-02	14.4	-35.6	-7.8
183	ok	0.19	2.48e-02	2.65e-05	5.7	5.7	5.7	5.7	0.3	0.5	0.1	-6.9	-75.6	-5.1
184	ok	0.19	2.48e-02	2.65e-05	5.7	5.7	5.7	5.7	0.3	0.7	-0.2	-16.6	-87.9	-3.3

Nodo	x/d	V N/M	ver. rid	Af pr-	Af pr+	Af sec-	Af sec+	N x	N y	N xy	M x	M y	M xy
								-1.89	-1.73	-2.83	-378.56	-477.58	-217.13
	0.19	0.16	1.42e-03	5.65	5.65	5.65	5.65	2.82	2.37	2.83	31.88	43.83	217.13

Nodo	Stato	Max tau daN/cm2	Ver V pr	Ver V sec	Af V pr	Af V sec	V pr daN/cm	V sec daN/cm
1	ok	0.61						
2	ok	0.56						
3	ok	0.56						
4	ok	0.61						
5	ok	0.60						
6	ok	0.60						
7	ok	0.51						
8	ok	0.51						
9	ok	0.57						
10	ok	0.47						
11	ok	0.57						
12	ok	0.47						
13	ok	0.61						
14	ok	0.61						
15	ok	0.43						
16	ok	0.43						
17	ok	0.24						
18	ok	0.24						
19	ok	0.20						

20	ok	0.20
21	ok	0.12
22	ok	0.12
23	ok	0.17
24	ok	0.17
25	ok	0.15
26	ok	0.15
27	ok	0.18
28	ok	0.18
29	ok	0.24
30	ok	0.24
31	ok	0.20
32	ok	0.20
33	ok	0.09
34	ok	0.14
35	ok	0.17
36	ok	0.10
37	ok	0.12
38	ok	0.12
39	ok	0.08
40	ok	0.08
41	ok	0.61
42	ok	0.61
43	ok	0.56
44	ok	0.56
45	ok	0.61
46	ok	0.56
47	ok	0.61
48	ok	0.56
49	ok	0.51
50	ok	0.61
51	ok	0.19
52	ok	0.14
53	ok	0.24
54	ok	0.24
55	ok	0.56
56	ok	0.17
57	ok	0.47
58	ok	0.47
59	ok	0.56
60	ok	0.61
61	ok	0.51
62	ok	0.19
63	ok	0.14
64	ok	0.24
65	ok	0.24
66	ok	0.61
67	ok	0.10
68	ok	0.61
69	ok	0.61
70	ok	0.61
81	ok	0.35
82	ok	0.26
83	ok	0.35
84	ok	0.26
85	ok	0.40

86	ok	0.39
87	ok	0.39
88	ok	0.40
89	ok	0.20
90	ok	0.20
91	ok	0.23
92	ok	0.23
93	ok	0.40
94	ok	0.39
95	ok	0.39
96	ok	0.40
97	ok	0.20
98	ok	0.20
99	ok	0.23
100	ok	0.23
143	ok	0.18
144	ok	0.20
145	ok	0.17
146	ok	0.17
147	ok	0.12
148	ok	0.11
149	ok	0.15
150	ok	0.11
151	ok	0.20
152	ok	0.18
153	ok	0.20
154	ok	0.18
155	ok	0.17
156	ok	0.17
157	ok	0.12
158	ok	0.11
159	ok	0.15
160	ok	0.11
161	ok	0.20
162	ok	0.18
163	ok	0.08
164	ok	0.18
165	ok	0.18
166	ok	0.19
167	ok	0.19
168	ok	0.09
169	ok	0.13
170	ok	0.09
171	ok	0.13
172	ok	0.18
173	ok	0.18
174	ok	0.19
175	ok	0.19
176	ok	0.09
177	ok	0.09
178	ok	0.09
179	ok	0.19
180	ok	0.19
181	ok	0.19
182	ok	0.19
183	ok	0.18

184

ok

0.18

Nodo

Max tau
0.61

Ver V pr

Ver V sec

Af V pr

Af V sec

V pr

V sec

STATI LIMITE D' ESERCIZIO

LEGENDA TABELLA STATI LIMITE D' ESERCIZIO

In tabella vengono riportati i valori di interesse per il controllo degli stati limite d'esercizio.

In particolare vengono riportati, in relazione al tipo di elemento strutturale, i risultati relativi alle tre categorie di combinazione considerate:

- Combinazioni rare
- Combinazioni frequenti
- Combinazioni quasi permanenti.

I valori di interesse sono i seguenti:

rRfck	rapporto tra la massima compressione nel calcestruzzo e la tensione fck in combinazioni rare [normalizzato a 1]
rRfyk	rapporto tra la massima tensione nell'acciaio e la tensione fyk in combinazioni rare [normalizzato a 1]
rPfck	rapporto tra la massima compressione nel calcestruzzo e la tensione fck in combinazioni quasi permanenti [normalizzato a 1]
wR	apertura caratteristica delle fessure in combinazioni rare [mm]
wF	apertura caratteristica delle fessure in combinazioni frequenti [mm]
wP	apertura caratteristica delle fessure in combinazioni quasi permanenti [mm]
dR	massima deformazione in combinazioni rare
dF	massima deformazione in combinazioni frequenti
dP	massima deformazione in combinazioni quasi permanenti

Per ognuno dei nove valori soprariportati viene indicata (Rif.cmb) la combinazione in cui si è verificato.

In relazione al tipo di elemento strutturale i valori sono selezionati nel modo seguente:

pilastrini	rRfck	rRfyk	rPfck	per sezioni significative
travi	rRfck	rRfyk	rPfck	per sezioni significative
	wR	wF	wP	per sezioni significative
	dR	dF	dP	massimi in campata
setti e gusci	rRfck	rRfyk	rPfck	massimi nei nodi dell'elemento
	wR	wF	wP	massimi nei nodi dell'elemento

Si precisa che i valori di massima deformazione per travi sono riferiti al piano verticale (piano locale 1-2 con momenti flettenti 3-3).

Guscio	rRfck	rRfyk	rPfck	Rif. cmb	wR	wF	wP	Rif. cmb
					mm	mm	mm	
1	0.02	0.03	0.0	2,2,0	0.0	0.0	0.0	0,0,0
2	0.01	0.03	0.0	2,2,0	0.0	0.0	0.0	0,0,0
3	0.02	0.03	0.0	2,2,0	0.0	0.0	0.0	0,0,0
4	0.03	0.04	0.0	2,2,0	0.0	0.0	0.0	0,0,0
5	0.01	0.03	0.0	2,2,0	0.0	0.0	0.0	0,0,0
6	0.03	0.05	0.0	2,2,0	0.0	0.0	0.0	0,0,0
7	0.01	0.02	0.0	2,2,0	0.0	0.0	0.0	0,0,0
8	0.02	0.04	0.0	2,2,0	0.0	0.0	0.0	0,0,0
9	0.01	0.02	0.0	2,2,0	0.0	0.0	0.0	0,0,0
10	0.03	0.05	0.0	2,2,0	0.0	0.0	0.0	0,0,0
11	0.03	0.05	0.0	2,2,0	0.0	0.0	0.0	0,0,0
12	0.03	0.05	0.0	2,2,0	0.0	0.0	0.0	0,0,0
13	0.02	0.04	0.0	2,2,0	0.0	0.0	0.0	0,0,0
14	0.02	0.04	0.0	2,2,0	0.0	0.0	0.0	0,0,0
15	0.02	0.04	0.0	2,2,0	0.0	0.0	0.0	0,0,0
16	0.02	0.03	0.0	2,2,0	0.0	0.0	0.0	0,0,0
17	9.85e-03	0.02	0.0	2,2,0	0.0	0.0	0.0	0,0,0
18	0.02	0.04	0.0	2,2,0	0.0	0.0	0.0	0,0,0
19	0.02	0.03	0.0	2,2,0	0.0	0.0	0.0	0,0,0
20	0.02	0.04	0.0	2,2,0	0.0	0.0	0.0	0,0,0
21	0.02	0.04	0.0	2,2,0	0.0	0.0	0.0	0,0,0
22	0.02	0.03	0.0	2,2,0	0.0	0.0	0.0	0,0,0
23	0.01	0.02	0.0	2,2,0	0.0	0.0	0.0	0,0,0
24	0.01	0.02	0.0	2,2,0	0.0	0.0	0.0	0,0,0
25	0.03	0.04	0.0	2,2,0	0.0	0.0	0.0	0,0,0
26	0.02	0.03	0.0	2,2,0	0.0	0.0	0.0	0,0,0
27	7.17e-03	0.01	0.0	2,2,0	0.0	0.0	0.0	0,0,0
28	0.02	0.04	0.0	2,2,0	0.0	0.0	0.0	0,0,0
29	0.01	0.03	0.0	2,2,0	0.0	0.0	0.0	0,0,0
30	0.03	0.05	0.0	2,2,0	0.0	0.0	0.0	0,0,0
31	0.01	0.02	0.0	2,2,0	0.0	0.0	0.0	0,0,0
32	0.03	0.05	0.0	2,2,0	0.0	0.0	0.0	0,0,0
33	0.02	0.04	0.0	2,2,0	0.0	0.0	0.0	0,0,0
34	0.02	0.04	0.0	2,2,0	0.0	0.0	0.0	0,0,0
35	0.02	0.04	0.0	2,2,0	0.0	0.0	0.0	0,0,0
36	0.01	0.02	0.0	2,2,0	0.0	0.0	0.0	0,0,0
37	0.03	0.04	0.0	2,2,0	0.0	0.0	0.0	0,0,0
38	0.01	0.02	0.0	2,2,0	0.0	0.0	0.0	0,0,0
39	0.02	0.04	0.0	2,2,0	0.0	0.0	0.0	0,0,0
40	0.01	0.02	0.0	2,2,0	0.0	0.0	0.0	0,0,0
41	0.02	0.03	0.0	2,2,0	0.0	0.0	0.0	0,0,0
42	0.02	0.03	0.0	2,2,0	0.0	0.0	0.0	0,0,0
43	0.01	0.02	0.0	2,2,0	0.0	0.0	0.0	0,0,0
44	0.03	0.05	0.0	2,2,0	0.0	0.0	0.0	0,0,0
45	0.02	0.04	0.0	2,2,0	0.0	0.0	0.0	0,0,0
46	0.02	0.03	0.0	2,2,0	0.0	0.0	0.0	0,0,0
47	0.02	0.03	0.0	2,2,0	0.0	0.0	0.0	0,0,0
48	0.01	0.02	0.0	2,2,0	0.0	0.0	0.0	0,0,0
49	0.02	0.04	0.0	2,2,0	0.0	0.0	0.0	0,0,0
50	0.02	0.03	0.0	2,2,0	0.0	0.0	0.0	0,0,0
51	0.02	0.03	0.0	2,2,0	0.0	0.0	0.0	0,0,0
52	0.01	0.02	0.0	2,2,0	0.0	0.0	0.0	0,0,0

53	0.02	0.03	0.0	2,2,0	0.0	0.0	0.0	0,0,0
54	0.02	0.04	0.0	2,2,0	0.0	0.0	0.0	0,0,0
65	0.01	0.03	0.0	2,2,0	0.0	0.0	0.0	0,0,0
66	0.03	0.04	0.0	2,2,0	0.0	0.0	0.0	0,0,0
67	0.02	0.04	0.0	2,2,0	0.0	0.0	0.0	0,0,0
68	0.03	0.05	0.0	2,2,0	0.0	0.0	0.0	0,0,0
69	0.02	0.04	0.0	2,2,0	0.0	0.0	0.0	0,0,0
70	9.85e-03	0.02	0.0	2,2,0	0.0	0.0	0.0	0,0,0
71	0.02	0.04	0.0	2,2,0	0.0	0.0	0.0	0,0,0
72	0.03	0.04	0.0	2,2,0	0.0	0.0	0.0	0,0,0
73	0.02	0.03	0.0	2,2,0	0.0	0.0	0.0	0,0,0
74	0.02	0.03	0.0	2,2,0	0.0	0.0	0.0	0,0,0
75	0.01	0.02	0.0	2,2,0	0.0	0.0	0.0	0,0,0
76	0.01	0.02	0.0	2,2,0	0.0	0.0	0.0	0,0,0
77	0.03	0.04	0.0	2,2,0	0.0	0.0	0.0	0,0,0
78	0.02	0.03	0.0	2,2,0	0.0	0.0	0.0	0,0,0
79	7.17e-03	0.01	0.0	2,2,0	0.0	0.0	0.0	0,0,0
80	0.02	0.04	0.0	2,2,0	0.0	0.0	0.0	0,0,0
81	0.02	0.04	0.0	2,2,0	0.0	0.0	0.0	0,0,0
82	0.01	0.02	0.0	2,2,0	0.0	0.0	0.0	0,0,0
137	7.60e-03	0.01	0.0	2,2,0	0.0	0.0	0.0	0,0,0
138	0.01	0.02	0.0	2,2,0	0.0	0.0	0.0	0,0,0
139	9.42e-03	0.02	0.0	2,2,0	0.0	0.0	0.0	0,0,0
140	0.02	0.04	0.0	2,2,0	0.0	0.0	0.0	0,0,0
141	0.02	0.04	0.0	2,2,0	0.0	0.0	0.0	0,0,0
142	0.01	0.02	0.0	2,2,0	0.0	0.0	0.0	0,0,0
143	0.01	0.03	0.0	2,2,0	0.0	0.0	0.0	0,0,0
144	9.05e-03	0.02	0.0	2,2,0	0.0	0.0	0.0	0,0,0
145	8.92e-03	0.02	0.0	2,2,0	0.0	0.0	0.0	0,0,0
146	7.60e-03	0.01	0.0	2,2,0	0.0	0.0	0.0	0,0,0
147	0.01	0.02	0.0	2,2,0	0.0	0.0	0.0	0,0,0
148	9.42e-03	0.02	0.0	2,2,0	0.0	0.0	0.0	0,0,0
149	0.02	0.04	0.0	2,2,0	0.0	0.0	0.0	0,0,0
150	0.02	0.04	0.0	2,2,0	0.0	0.0	0.0	0,0,0
151	0.01	0.02	0.0	2,2,0	0.0	0.0	0.0	0,0,0
152	0.01	0.03	0.0	2,2,0	0.0	0.0	0.0	0,0,0
153	9.05e-03	0.02	0.0	2,2,0	0.0	0.0	0.0	0,0,0
154	8.92e-03	0.02	0.0	2,2,0	0.0	0.0	0.0	0,0,0
155	7.61e-03	0.01	0.0	2,2,0	0.0	0.0	0.0	0,0,0
156	0.01	0.02	0.0	2,2,0	0.0	0.0	0.0	0,0,0
157	9.44e-03	0.02	0.0	2,2,0	0.0	0.0	0.0	0,0,0
158	0.01	0.02	0.0	2,2,0	0.0	0.0	0.0	0,0,0
159	9.44e-03	0.02	0.0	2,2,0	0.0	0.0	0.0	0,0,0
160	7.61e-03	0.01	0.0	2,2,0	0.0	0.0	0.0	0,0,0
161	0.01	0.02	0.0	2,2,0	0.0	0.0	0.0	0,0,0
162	0.01	0.02	0.0	2,2,0	0.0	0.0	0.0	0,0,0
163	5.37e-03	9.17e-03	0.0	2,2,0	0.0	0.0	0.0	0,0,0
164	5.37e-03	9.17e-03	0.0	2,2,0	0.0	0.0	0.0	0,0,0
165	9.01e-03	0.02	0.0	2,2,0	0.0	0.0	0.0	0,0,0
166	0.01	0.02	0.0	2,2,0	0.0	0.0	0.0	0,0,0
167	0.01	0.02	0.0	2,2,0	0.0	0.0	0.0	0,0,0
168	9.09e-03	0.02	0.0	2,2,0	0.0	0.0	0.0	0,0,0
169	0.01	0.02	0.0	2,2,0	0.0	0.0	0.0	0,0,0
170	9.01e-03	0.02	0.0	2,2,0	0.0	0.0	0.0	0,0,0
171	0.01	0.02	0.0	2,2,0	0.0	0.0	0.0	0,0,0
172	9.09e-03	0.02	0.0	2,2,0	0.0	0.0	0.0	0,0,0

173	5.73e-03	9.41e-03	0.0	2,2,0	0.0	0.0	0.0	0,0,0
174	5.73e-03	9.41e-03	0.0	2,2,0	0.0	0.0	0.0	0,0,0
Guscio	rRfck	rRfyk	rPfck		wR	wF	wP	
	0.03	0.05	0.0		0.0	0.0	0.0	

STATO LIMITE D' ESERCIZIO: SLD DANNO SISMICO

LEGENDA TABELLA STATI LIMITE DI DANNO (VERIFICHE RES)

Le verifiche RES per SLD sono effettuate in accordo alle Norme Tecniche 17 Gennaio 2018 e alla circolare n.7 del 21 gennaio 2019 nonché alle linee guida del Consiglio Superiore LL.PP. "Linee guida per la Progettazione, l'Esecuzione ed il Collaudo di Interventi di Rinforzo di strutture di c.a., c.a.p. e murarie mediante FRP".

Le verifiche RES per SLD, sono riportate nelle successive tabelle nella forma di rapporto "domanda" su "capacità" e hanno esito positivo quando il rapporto è non superiore al valore unitario.

La "domanda" è ottenuta direttamente dall'analisi per le previste combinazioni SLD (NTC18 2.5.3. COMBINAZIONI DELLE AZIONI formula [2.5.5]).

Per "capacità" si intende qui il valore della sollecitazione corrispondente al raggiungimento dello stato limite di danno per la sezione: per la resistenza flessionale questo stato limite si identifica con la tensione di snervamento dell'acciaio o la resistenza massima a compressione per il calcestruzzo e la muratura. Lo stato limite di danno si ritiene attinto anche in caso di superamento della resistenza a taglio.

Le resistenze flessionali sono valutate utilizzando i legami costitutivi del materiale limitati al solo tratto elastico, ottenendo così resistenze sostanzialmente elastiche come previsto dalla norma.

La seguente tabella identifica per quali configurazioni (materiale nuovo, esistente, con rinforzi e metodo di analisi) sono state condotte le verifiche di seguito riportate.

Configurazione	Verifica SLD	NOTE
1) c.a. nuovo e esist. Verifica SLU con $q>1$	Verifica N/M SE Verifica V/T	Sono verifiche per struttura non dissipativa condotte secondo il cap.4 NTC18 in regime sostanzialmente elastico; si verificano travi, pilastri, setti e gusci.
2) Muratura nuova Verifica SLU con $q>1$	Verifica N/M SE Verifica V	Per N/M identificato SL elastico, per V formulazione secondo cap.7
3) Muratura esis. AO Verifica SLU con $q>1$	Verifica N/M SE Verifica V	Per N/M identificato SL elastico, per V formulazione secondo cap. 7 e 8
4) Muratura esis. PO Verifica SLU con $q>1$	Verifica N/M SE Verifica V	Per N/M identificato SL elastico, per V formulazione secondo cap. 7 e 8; Anche per rinforzi FRP è prevista verifica N/M SE e V

Simbologia adottata nelle tabelle di verifica

Per le verifiche agli SLD di pilastri, travi setti e gusci in c.a. è presente una tabella con i simboli di seguito descritti:

Pilas./Trave/ Setto/Guscio	numero identificativo dell'elemento D2 o D3
Stato	Codici relativi all'esito delle verifiche effettuate appresso descritte
Pos.	Posizione nell'elemento della sezione per la quale si riporta la verifica
V N/M	Verifica a pressoflessione con rapporto Ed/Rd: valore minore o uguale a 1 per verifica positiva
V V/T cls	Verifica a taglio/torsione con rapporto Ved/Vrd lato cls: valore minore o uguale a 1 per verifica positiva
V V/T acc	Verifica a taglio/torsione con rapporto Ved/Vrd lato acciaio: valore minore o uguale a 1 per verifica positiva
Rif. cmb.	Riferimento combinazioni da cui si generano le verifiche più gravose per il pilastro

Per le verifiche agli SLD di maschi e fasce in muratura, è presente una tabella con i simboli di seguito descritti:

Setto/Fascia/Elem.	numero del macroelemento (D3) o elemento (D2) considerato	
Mat.	Materiale	
s=,m=	Indice della sezione e del materiale assegnati all' elemento (per D2)	
Spessore	spessore dell'elemento	
Stato	ok	elemento verificato (SLD)
	NV	elemento non verificato (SLD)

e a seguire:

Nodo/Pos.	numero del nodo appartenente al setto / posizione relativa al nodo I per D2
h0/t	valore della snellezza convenzionale
P/Ap	tensione verticale media utilizzata per la verifica a pressoflessione nel piano del muro
P/Acv	tensione verticale media nella parte compressa, utilizzata nella verifica a taglio nel piano del muro
Ver. Mp	rapporto tra il momento di progetto e il momento Mrd in relazione alla verifica Par. 7.8.2.2.1 (pressoflessione complanare) effettuato per tutte le combinazioni
Ver. V	rapporto il taglio di progetto e il taglio ultimo in relazione alla verifica Par. 7.8.2.2.2 (taglio complanare) o C8.7.1.16 della circolare 21-01-19 per edifici esistenti effettuato per tutte le combinazioni (solo per elementi maschi)
Ver. V	rapporto tra il taglio di progetto e il minore dei tagli resistenti Vp e Vt in relazione alla verifica del par. 7.8.2.2.3 (solo per elementi fasce)
Rif. cmb	Combinazioni in cui si hanno i massimi valori dei rapporti Ver. Mp, Ver. V

Per elementi consolidati secondo il paragrafo C8.5.3.1 il programma opera come per gli elementi non rinforzati, considerando ai fini delle analisi e delle verifiche gli opportuni coefficienti correttivi delle rigidità e delle resistenze.

Per elementi consolidati con FRP il programma implementa le verifiche previste dalle "Linee guida per la Progettazione, l'Esecuzione ed il Collaudo di Interventi di Rinforzo di strutture di c.a., c.a.p. e murarie mediante FRP" approvate dal CSLLPP il 24/07/2009.

Per elementi consolidati con FRCM il programma implementa le verifiche previste dalle CNR-DT 215/2018 "Istruzioni per la Progettazione, l'Esecuzione ed il Controllo di Interventi di Consolidamento Statico mediante l'utilizzo di Compositi Fibrorinforzati a Matrice Inorganica"

Per semplicità la simbologia adottata nelle tabelle è uniformata a quella degli elementi non rinforzati.

Le tabelle riportano inoltre i seguenti parametri:

Fibra	Tipo di fibra del fibrorinforzo
E fibra	Modulo elastico del fibrorinforzo
epsr	Dilatazione di rottura del fibrorinforzo
epsd	Dilatazione di calcolo
epsd(s)	Dilatazione di calcolo per combinazioni sismiche
Spess.	Spessore del fibrorinforzo, il programma prevede l' applicazione di uno strato di spessore s su entrambe le facce della parete (o sui quattro lati della sezione in caso di confinamento)
AO fib.	Area orizzontale complessiva di fibrorinforzo per metro lineare
AV fib.	Area verticale complessiva di fibrorinforzo per metro lineare

Affinché l'elemento sia verificato deve essere:

Ver. Mp, Ver.V non superiore a 1

TABELLA VERIFICHE ELEMENTI D3 GUSCI C.A.

--

Guscio	Stato	Nodo	V N/M	V V/T cls	V V/T acc	Rif. cmb	Nodo	V N/M	V V/T cls	V V/T acc	Rif. cmb
1	ok	55	0.07	0.0	0.0	63,0,0	48	0.04	0.0	0.0	50,0,0
		3	0.01	0.0	0.0	51,0,0	44	0.04	0.0	0.0	63,0,0
2	ok	93	0.04	0.0	0.0	51,0,0	82	0.03	0.0	0.0	61,0,0
		12	0.02	0.0	0.0	61,0,0	57	0.02	0.0	0.0	51,0,0
3	ok	66	0.07	0.0	0.0	66,0,0	50	0.06	0.0	0.0	45,0,0
		6	0.02	0.0	0.0	60,0,0	42	0.05	0.0	0.0	66,0,0
4	ok	95	0.03	0.0	0.0	60,0,0	94	0.03	0.0	0.0	45,0,0
		13	0.05	0.0	0.0	60,0,0	68	0.04	0.0	0.0	60,0,0
5	ok	59	0.07	0.0	0.0	63,0,0	46	0.04	0.0	0.0	47,0,0
		10	0.02	0.0	0.0	35,0,0	58	0.06	0.0	0.0	57,0,0
6	ok	69	0.07	0.0	0.0	66,0,0	60	0.06	0.0	0.0	47,0,0
		14	0.05	0.0	0.0	66,0,0	70	0.06	0.0	0.0	66,0,0
7	ok	51	0.02	0.0	0.0	38,0,0	49	0.02	0.0	0.0	51,0,0
		8	0.02	0.0	0.0	51,0,0	26	0.02	0.0	0.0	37,0,0
8	ok	97	0.02	0.0	0.0	61,0,0	96	0.04	0.0	0.0	51,0,0
		15	0.03	0.0	0.0	35,0,0	31	0.02	0.0	0.0	51,0,0
9	ok	62	0.02	0.0	0.0	41,0,0	61	0.02	0.0	0.0	39,0,0
		16	0.03	0.0	0.0	39,0,0	32	0.02	0.0	0.0	57,0,0
10	ok	53	0.05	0.0	0.0	51,0,0	52	0.04	0.0	0.0	51,0,0
		21	0.04	0.0	0.0	51,0,0	23	0.05	0.0	0.0	51,0,0
11	ok	99	0.05	0.0	0.0	35,0,0	98	0.05	0.0	0.0	35,0,0
		19	0.03	0.0	0.0	51,0,0	17	0.06	0.0	0.0	51,0,0
12	ok	64	0.05	0.0	0.0	57,0,0	63	0.04	0.0	0.0	57,0,0
		20	0.03	0.0	0.0	57,0,0	18	0.06	0.0	0.0	57,0,0

13	ok	54	0.01	0.0	0.0	44,0,0	53	0.04	0.0	0.0	51,0,0
		23	0.04	0.0	0.0	51,0,0	28	6.13e-03	0.0	0.0	47,0,0
14	ok	100	8.43e-03	0.0	0.0	38,0,0	99	0.04	0.0	0.0	61,0,0
		17	0.04	0.0	0.0	35,0,0	29	0.01	0.0	0.0	47,0,0
15	ok	65	0.01	0.0	0.0	45,0,0	64	0.04	0.0	0.0	57,0,0
		18	0.04	0.0	0.0	41,0,0	30	0.02	0.0	0.0	48,0,0
16	ok	50	0.03	0.0	0.0	60,0,0	54	9.00e-03	0.0	0.0	46,0,0
		28	0.01	0.0	0.0	44,0,0	6	0.02	0.0	0.0	60,0,0
17	ok	94	0.02	0.0	0.0	44,0,0	100	9.03e-03	0.0	0.0	44,0,0
		29	6.90e-03	0.0	0.0	56,0,0	13	0.02	0.0	0.0	60,0,0
18	ok	60	0.03	0.0	0.0	50,0,0	65	8.67e-03	0.0	0.0	66,0,0
		30	0.01	0.0	0.0	60,0,0	14	0.04	0.0	0.0	66,0,0
19	ok	52	0.03	0.0	0.0	38,0,0	51	0.02	0.0	0.0	51,0,0
		26	0.02	0.0	0.0	51,0,0	21	0.03	0.0	0.0	38,0,0
20	ok	98	0.04	0.0	0.0	41,0,0	97	0.01	0.0	0.0	61,0,0
		31	0.02	0.0	0.0	61,0,0	19	0.04	0.0	0.0	41,0,0
21	ok	63	0.03	0.0	0.0	40,0,0	62	0.02	0.0	0.0	57,0,0
		32	0.02	0.0	0.0	57,0,0	20	0.04	0.0	0.0	40,0,0
22	ok	85	0.03	0.0	0.0	41,0,0	84	0.03	0.0	0.0	57,0,0
		34	0.02	0.0	0.0	57,0,0	56	0.02	0.0	0.0	39,0,0
23	ok	87	0.02	0.0	0.0	44,0,0	86	0.02	0.0	0.0	44,0,0
		36	0.01	0.0	0.0	50,0,0	67	0.01	0.0	0.0	50,0,0
24	ok	89	0.01	0.0	0.0	41,0,0	88	0.03	0.0	0.0	57,0,0
		35	0.01	0.0	0.0	57,0,0	37	0.02	0.0	0.0	41,0,0
25	ok	91	0.05	0.0	0.0	41,0,0	90	0.05	0.0	0.0	41,0,0
		38	0.05	0.0	0.0	35,0,0	39	0.04	0.0	0.0	38,0,0
26	ok	92	8.52e-03	0.0	0.0	56,0,0	91	0.04	0.0	0.0	63,0,0
		39	0.03	0.0	0.0	45,0,0	40	0.01	0.0	0.0	66,0,0
27	ok	86	0.02	0.0	0.0	47,0,0	92	0.01	0.0	0.0	48,0,0
		40	0.01	0.0	0.0	50,0,0	36	8.02e-03	0.0	0.0	50,0,0
28	ok	90	0.04	0.0	0.0	40,0,0	89	0.01	0.0	0.0	40,0,0
		37	0.02	0.0	0.0	63,0,0	38	0.03	0.0	0.0	41,0,0
29	ok	57	0.06	0.0	0.0	51,0,0	12	0.02	0.0	0.0	41,0,0
		48	0.04	0.0	0.0	45,0,0	55	0.07	0.0	0.0	61,0,0
30	ok	68	0.06	0.0	0.0	60,0,0	13	0.05	0.0	0.0	60,0,0
		50	0.06	0.0	0.0	45,0,0	66	0.07	0.0	0.0	60,0,0
31	ok	31	0.02	0.0	0.0	51,0,0	15	0.03	0.0	0.0	37,0,0
		49	0.02	0.0	0.0	37,0,0	51	0.02	0.0	0.0	35,0,0
32	ok	17	0.06	0.0	0.0	51,0,0	19	0.03	0.0	0.0	51,0,0
		52	0.04	0.0	0.0	51,0,0	53	0.05	0.0	0.0	51,0,0
33	ok	29	0.02	0.0	0.0	46,0,0	17	0.04	0.0	0.0	35,0,0
		53	0.04	0.0	0.0	51,0,0	54	0.01	0.0	0.0	47,0,0
34	ok	13	0.04	0.0	0.0	60,0,0	29	0.01	0.0	0.0	66,0,0
		54	8.67e-03	0.0	0.0	60,0,0	50	0.03	0.0	0.0	44,0,0
35	ok	19	0.04	0.0	0.0	38,0,0	31	0.02	0.0	0.0	51,0,0
		51	0.02	0.0	0.0	51,0,0	52	0.03	0.0	0.0	38,0,0
36	ok	49	0.05	0.0	0.0	38,0,0	55	0.06	0.0	0.0	57,0,0
		44	0.04	0.0	0.0	57,0,0	8	0.02	0.0	0.0	61,0,0
37	ok	96	0.05	0.0	0.0	51,0,0	93	0.03	0.0	0.0	51,0,0
		57	0.03	0.0	0.0	51,0,0	15	0.02	0.0	0.0	51,0,0
38	ok	61	0.05	0.0	0.0	40,0,0	59	0.06	0.0	0.0	57,0,0
		58	0.06	0.0	0.0	57,0,0	16	0.02	0.0	0.0	57,0,0
39	ok	88	0.04	0.0	0.0	39,0,0	85	0.03	0.0	0.0	39,0,0
		56	0.02	0.0	0.0	41,0,0	35	0.01	0.0	0.0	41,0,0
40	ok	15	0.02	0.0	0.0	51,0,0	57	0.06	0.0	0.0	51,0,0
		55	0.06	0.0	0.0	51,0,0	49	0.05	0.0	0.0	38,0,0

41	ok	43	0.04	0.0	0.0	61,0,0	2	0.01	0.0	0.0	57,0,0
		46	0.04	0.0	0.0	44,0,0	59	0.07	0.0	0.0	61,0,0
42	ok	41	0.05	0.0	0.0	60,0,0	5	0.02	0.0	0.0	66,0,0
		60	0.06	0.0	0.0	47,0,0	69	0.07	0.0	0.0	60,0,0
43	ok	25	0.02	0.0	0.0	39,0,0	7	0.02	0.0	0.0	57,0,0
		61	0.02	0.0	0.0	57,0,0	62	0.02	0.0	0.0	40,0,0
44	ok	24	0.05	0.0	0.0	57,0,0	22	0.04	0.0	0.0	57,0,0
		63	0.04	0.0	0.0	57,0,0	64	0.05	0.0	0.0	57,0,0
45	ok	27	6.13e-03	0.0	0.0	45,0,0	24	0.04	0.0	0.0	57,0,0
		64	0.04	0.0	0.0	57,0,0	65	0.01	0.0	0.0	50,0,0
46	ok	5	0.02	0.0	0.0	66,0,0	27	0.01	0.0	0.0	50,0,0
		65	9.00e-03	0.0	0.0	48,0,0	60	0.03	0.0	0.0	66,0,0
47	ok	22	0.03	0.0	0.0	40,0,0	25	0.02	0.0	0.0	57,0,0
		62	0.02	0.0	0.0	57,0,0	63	0.03	0.0	0.0	40,0,0
48	ok	7	0.02	0.0	0.0	63,0,0	43	0.04	0.0	0.0	51,0,0
		59	0.06	0.0	0.0	51,0,0	61	0.05	0.0	0.0	40,0,0
49	ok	47	0.04	0.0	0.0	41,0,0	66	0.08	0.0	0.0	56,0,0
		42	0.04	0.0	0.0	66,0,0	4	0.01	0.0	0.0	60,0,0
50	ok	81	0.02	0.0	0.0	60,0,0	95	0.03	0.0	0.0	60,0,0
		68	0.03	0.0	0.0	60,0,0	11	0.03	0.0	0.0	62,0,0
51	ok	45	0.04	0.0	0.0	40,0,0	69	0.08	0.0	0.0	56,0,0
		70	0.06	0.0	0.0	66,0,0	9	0.02	0.0	0.0	44,0,0
52	ok	83	0.02	0.0	0.0	48,0,0	87	0.02	0.0	0.0	48,0,0
		67	0.01	0.0	0.0	50,0,0	33	8.01e-03	0.0	0.0	66,0,0
53	ok	11	0.02	0.0	0.0	50,0,0	68	0.06	0.0	0.0	60,0,0
		66	0.08	0.0	0.0	54,0,0	47	0.04	0.0	0.0	38,0,0
54	ok	1	0.01	0.0	0.0	66,0,0	41	0.04	0.0	0.0	60,0,0
		69	0.08	0.0	0.0	54,0,0	45	0.04	0.0	0.0	35,0,0
65	ok	58	0.02	0.0	0.0	57,0,0	10	0.02	0.0	0.0	63,0,0
		84	0.03	0.0	0.0	63,0,0	85	0.04	0.0	0.0	57,0,0
66	ok	70	0.04	0.0	0.0	66,0,0	14	0.05	0.0	0.0	66,0,0
		86	0.03	0.0	0.0	47,0,0	87	0.03	0.0	0.0	66,0,0
67	ok	32	0.02	0.0	0.0	57,0,0	16	0.03	0.0	0.0	41,0,0
		88	0.04	0.0	0.0	57,0,0	89	0.02	0.0	0.0	63,0,0
68	ok	18	0.06	0.0	0.0	57,0,0	20	0.03	0.0	0.0	57,0,0
		90	0.05	0.0	0.0	41,0,0	91	0.05	0.0	0.0	41,0,0
69	ok	30	0.01	0.0	0.0	45,0,0	18	0.04	0.0	0.0	41,0,0
		91	0.04	0.0	0.0	63,0,0	92	8.43e-03	0.0	0.0	40,0,0
70	ok	14	0.02	0.0	0.0	66,0,0	30	6.90e-03	0.0	0.0	54,0,0
		92	9.03e-03	0.0	0.0	50,0,0	86	0.02	0.0	0.0	50,0,0
71	ok	20	0.04	0.0	0.0	35,0,0	32	0.02	0.0	0.0	63,0,0
		89	0.01	0.0	0.0	63,0,0	90	0.04	0.0	0.0	35,0,0
72	ok	16	0.02	0.0	0.0	57,0,0	58	0.03	0.0	0.0	57,0,0
		85	0.03	0.0	0.0	57,0,0	88	0.05	0.0	0.0	57,0,0
73	ok	9	0.03	0.0	0.0	64,0,0	70	0.03	0.0	0.0	66,0,0
		87	0.03	0.0	0.0	66,0,0	83	0.02	0.0	0.0	66,0,0
74	ok	56	0.02	0.0	0.0	37,0,0	34	0.02	0.0	0.0	51,0,0
		82	0.03	0.0	0.0	51,0,0	93	0.03	0.0	0.0	35,0,0
75	ok	67	0.01	0.0	0.0	44,0,0	36	0.01	0.0	0.0	44,0,0
		94	0.02	0.0	0.0	50,0,0	95	0.02	0.0	0.0	50,0,0
76	ok	37	0.02	0.0	0.0	35,0,0	35	0.01	0.0	0.0	51,0,0
		96	0.03	0.0	0.0	51,0,0	97	0.01	0.0	0.0	35,0,0
77	ok	39	0.04	0.0	0.0	40,0,0	38	0.05	0.0	0.0	41,0,0
		98	0.05	0.0	0.0	35,0,0	99	0.05	0.0	0.0	35,0,0
78	ok	40	0.01	0.0	0.0	60,0,0	39	0.03	0.0	0.0	47,0,0
		99	0.04	0.0	0.0	61,0,0	100	8.52e-03	0.0	0.0	54,0,0

79	ok	36	8.02e-03	0.0	0.0	44,0,0	40	0.01	0.0	0.0	44,0,0
		100	0.01	0.0	0.0	46,0,0	94	0.02	0.0	0.0	45,0,0
80	ok	38	0.03	0.0	0.0	35,0,0	37	0.02	0.0	0.0	61,0,0
		97	0.01	0.0	0.0	38,0,0	98	0.04	0.0	0.0	38,0,0
81	ok	35	0.01	0.0	0.0	35,0,0	56	0.02	0.0	0.0	35,0,0
		93	0.03	0.0	0.0	37,0,0	96	0.04	0.0	0.0	37,0,0
82	ok	33	8.01e-03	0.0	0.0	60,0,0	67	0.01	0.0	0.0	44,0,0
		95	0.02	0.0	0.0	46,0,0	81	0.02	0.0	0.0	46,0,0
137	ok	44	0.02	0.0	0.0	41,0,0	3	0.01	0.0	0.0	41,0,0
		143	5.95e-03	0.0	0.0	57,0,0	152	9.54e-03	0.0	0.0	57,0,0
138	ok	42	0.02	0.0	0.0	60,0,0	6	0.02	0.0	0.0	60,0,0
		145	0.02	0.0	0.0	50,0,0	151	0.01	0.0	0.0	50,0,0
139	ok	26	0.02	0.0	0.0	38,0,0	8	0.02	0.0	0.0	38,0,0
		146	0.01	0.0	0.0	38,0,0	149	0.02	0.0	0.0	41,0,0
140	ok	23	0.05	0.0	0.0	51,0,0	21	0.04	0.0	0.0	51,0,0
		147	0.04	0.0	0.0	51,0,0	148	0.05	0.0	0.0	51,0,0
141	ok	28	5.87e-03	0.0	0.0	54,0,0	23	0.04	0.0	0.0	51,0,0
		148	0.04	0.0	0.0	51,0,0	150	7.02e-03	0.0	0.0	54,0,0
142	ok	6	0.02	0.0	0.0	46,0,0	28	0.01	0.0	0.0	46,0,0
		150	9.16e-03	0.0	0.0	44,0,0	145	0.02	0.0	0.0	44,0,0
143	ok	21	0.03	0.0	0.0	38,0,0	26	0.02	0.0	0.0	51,0,0
		149	0.02	0.0	0.0	51,0,0	147	0.03	0.0	0.0	38,0,0
144	ok	8	0.02	0.0	0.0	51,0,0	44	0.01	0.0	0.0	51,0,0
		152	0.01	0.0	0.0	57,0,0	146	0.01	0.0	0.0	41,0,0
145	ok	4	0.01	0.0	0.0	45,0,0	42	0.02	0.0	0.0	50,0,0
		151	0.01	0.0	0.0	66,0,0	144	7.74e-03	0.0	0.0	66,0,0
146	ok	162	9.54e-03	0.0	0.0	51,0,0	154	5.95e-03	0.0	0.0	51,0,0
		2	0.01	0.0	0.0	35,0,0	43	0.02	0.0	0.0	35,0,0
147	ok	161	0.01	0.0	0.0	44,0,0	155	0.02	0.0	0.0	44,0,0
		5	0.02	0.0	0.0	66,0,0	41	0.02	0.0	0.0	66,0,0
148	ok	159	0.02	0.0	0.0	35,0,0	156	0.01	0.0	0.0	40,0,0
		7	0.02	0.0	0.0	40,0,0	25	0.02	0.0	0.0	40,0,0
149	ok	158	0.05	0.0	0.0	57,0,0	157	0.04	0.0	0.0	57,0,0
		22	0.04	0.0	0.0	57,0,0	24	0.05	0.0	0.0	57,0,0
150	ok	160	7.02e-03	0.0	0.0	56,0,0	158	0.04	0.0	0.0	57,0,0
		24	0.04	0.0	0.0	57,0,0	27	5.87e-03	0.0	0.0	56,0,0
151	ok	155	0.02	0.0	0.0	50,0,0	160	9.16e-03	0.0	0.0	50,0,0
		27	0.01	0.0	0.0	48,0,0	5	0.02	0.0	0.0	48,0,0
152	ok	157	0.03	0.0	0.0	40,0,0	159	0.02	0.0	0.0	57,0,0
		25	0.02	0.0	0.0	57,0,0	22	0.03	0.0	0.0	40,0,0
153	ok	156	0.01	0.0	0.0	35,0,0	162	0.01	0.0	0.0	51,0,0
		43	0.01	0.0	0.0	57,0,0	7	0.02	0.0	0.0	57,0,0
154	ok	153	7.74e-03	0.0	0.0	60,0,0	161	0.01	0.0	0.0	60,0,0
		41	0.02	0.0	0.0	44,0,0	1	0.01	0.0	0.0	47,0,0
155	ok	48	0.02	0.0	0.0	61,0,0	180	0.01	0.0	0.0	45,0,0
		173	6.96e-03	0.0	0.0	45,0,0	3	0.01	0.0	0.0	61,0,0
156	ok	82	0.03	0.0	0.0	61,0,0	164	0.02	0.0	0.0	51,0,0
		175	0.02	0.0	0.0	61,0,0	12	0.02	0.0	0.0	61,0,0
157	ok	46	0.01	0.0	0.0	41,0,0	179	0.01	0.0	0.0	63,0,0
		174	0.02	0.0	0.0	63,0,0	10	0.02	0.0	0.0	41,0,0
158	ok	84	0.03	0.0	0.0	57,0,0	165	0.02	0.0	0.0	41,0,0
		176	0.02	0.0	0.0	57,0,0	34	0.02	0.0	0.0	57,0,0
159	ok	12	0.02	0.0	0.0	35,0,0	175	0.02	0.0	0.0	61,0,0
		180	0.01	0.0	0.0	61,0,0	48	0.01	0.0	0.0	35,0,0
160	ok	2	0.01	0.0	0.0	63,0,0	172	6.96e-03	0.0	0.0	47,0,0
		179	0.01	0.0	0.0	47,0,0	46	0.02	0.0	0.0	63,0,0

161	ok	10	0.02	0.0	0.0	63,0,0	174	0.02	0.0	0.0	63,0,0
		165	0.02	0.0	0.0	57,0,0	84	0.03	0.0	0.0	63,0,0
162	ok	34	0.02	0.0	0.0	51,0,0	176	0.02	0.0	0.0	51,0,0
		164	0.02	0.0	0.0	35,0,0	82	0.03	0.0	0.0	51,0,0
163	ok	3	0.01	0.0	0.0	63,0,0	173	6.98e-03	0.0	0.0	61,0,0
		168	5.14e-03	0.0	0.0	51,0,0	143	5.52e-03	0.0	0.0	41,0,0
164	ok	154	5.52e-03	0.0	0.0	35,0,0	170	5.14e-03	0.0	0.0	57,0,0
		172	6.98e-03	0.0	0.0	63,0,0	2	0.01	0.0	0.0	61,0,0
165	ok	167	0.01	0.0	0.0	38,0,0	47	0.02	0.0	0.0	54,0,0
		4	0.01	0.0	0.0	60,0,0	182	8.28e-03	0.0	0.0	38,0,0
166	ok	169	0.02	0.0	0.0	60,0,0	81	0.02	0.0	0.0	60,0,0
		11	0.02	0.0	0.0	54,0,0	184	0.02	0.0	0.0	60,0,0
167	ok	166	0.01	0.0	0.0	56,0,0	45	0.02	0.0	0.0	50,0,0
		9	0.02	0.0	0.0	48,0,0	183	0.02	0.0	0.0	56,0,0
168	ok	171	0.02	0.0	0.0	50,0,0	83	0.02	0.0	0.0	48,0,0
		33	8.15e-03	0.0	0.0	66,0,0	163	8.74e-03	0.0	0.0	66,0,0
169	ok	184	0.02	0.0	0.0	54,0,0	11	0.02	0.0	0.0	46,0,0
		47	0.02	0.0	0.0	44,0,0	167	0.01	0.0	0.0	54,0,0
170	ok	181	8.28e-03	0.0	0.0	40,0,0	1	0.01	0.0	0.0	66,0,0
		45	0.02	0.0	0.0	56,0,0	166	0.01	0.0	0.0	40,0,0
171	ok	183	0.02	0.0	0.0	66,0,0	9	0.02	0.0	0.0	56,0,0
		83	0.02	0.0	0.0	66,0,0	171	0.02	0.0	0.0	66,0,0
172	ok	163	8.74e-03	0.0	0.0	60,0,0	33	8.15e-03	0.0	0.0	60,0,0
		81	0.02	0.0	0.0	46,0,0	169	0.02	0.0	0.0	44,0,0
173	ok	182	8.81e-03	0.0	0.0	54,0,0	4	0.01	0.0	0.0	56,0,0
		144	8.10e-03	0.0	0.0	50,0,0	177	5.49e-03	0.0	0.0	60,0,0
174	ok	178	5.49e-03	0.0	0.0	66,0,0	153	8.10e-03	0.0	0.0	44,0,0
		1	0.01	0.0	0.0	54,0,0	181	8.81e-03	0.0	0.0	56,0,0

Guscio

V N/M **V V/T cls** **V V/T acc**
0.08 0.0 0.0

V N/M **V V/T cls** **V V/T acc**